

Solid Biomass CHP Plants — The Austrian Success Story

Workshop „Current Potentials for Biomass CHP in Europe“

26. February 2003, Athens

*Gerfried Jungmeier, Hannes Schwaiger JOANNEUM RESEARCH
Institute of Energy Research, Elisabethstrasse 5, 8010 Graz, AUSTRIA
gerfried.jungmeier@joanneum.at; Ph: +43 316 876 1313*

Overview

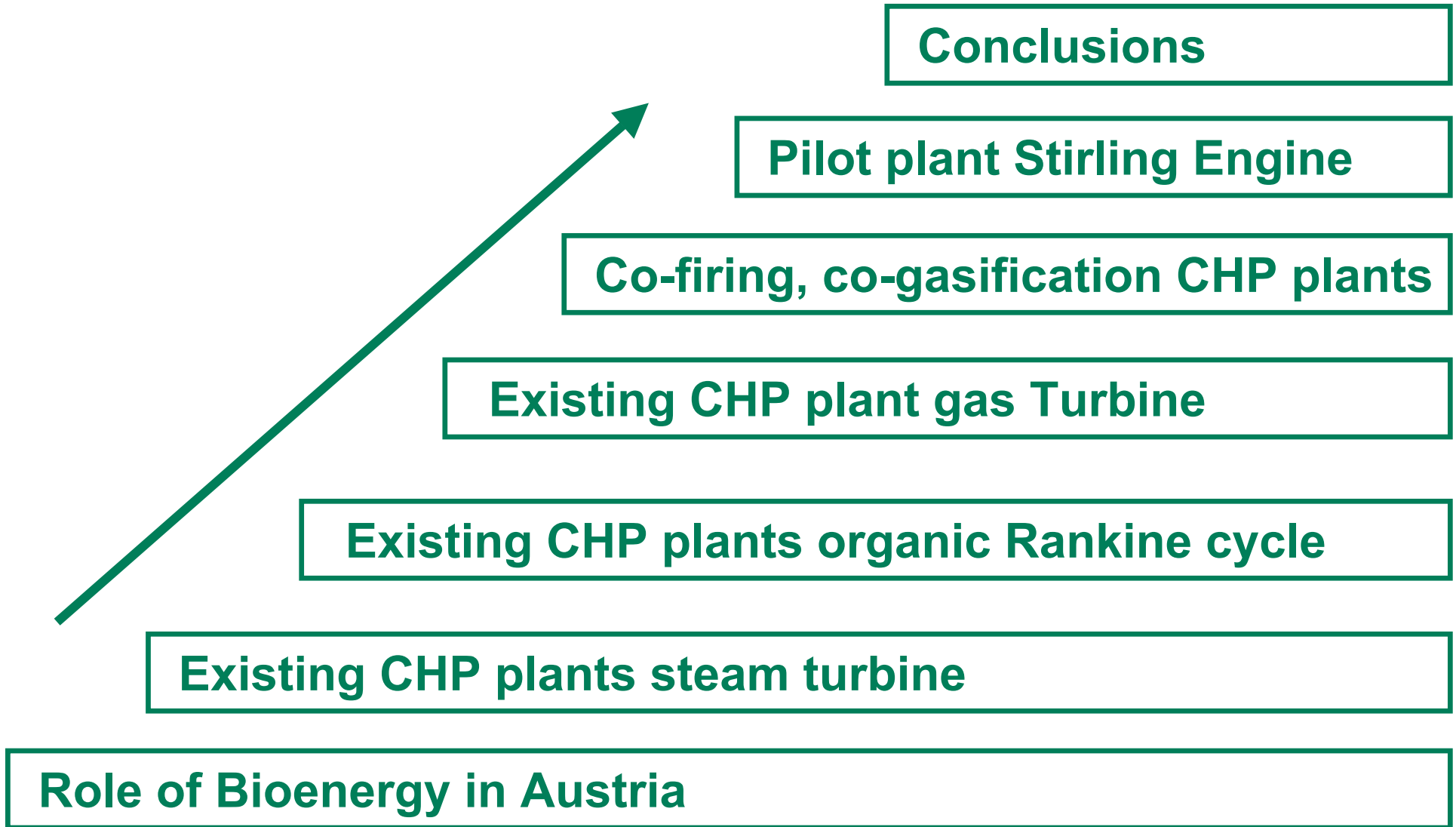

Energy Flow of Austria 1995

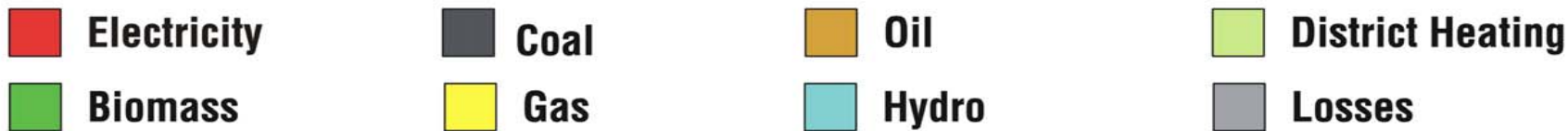
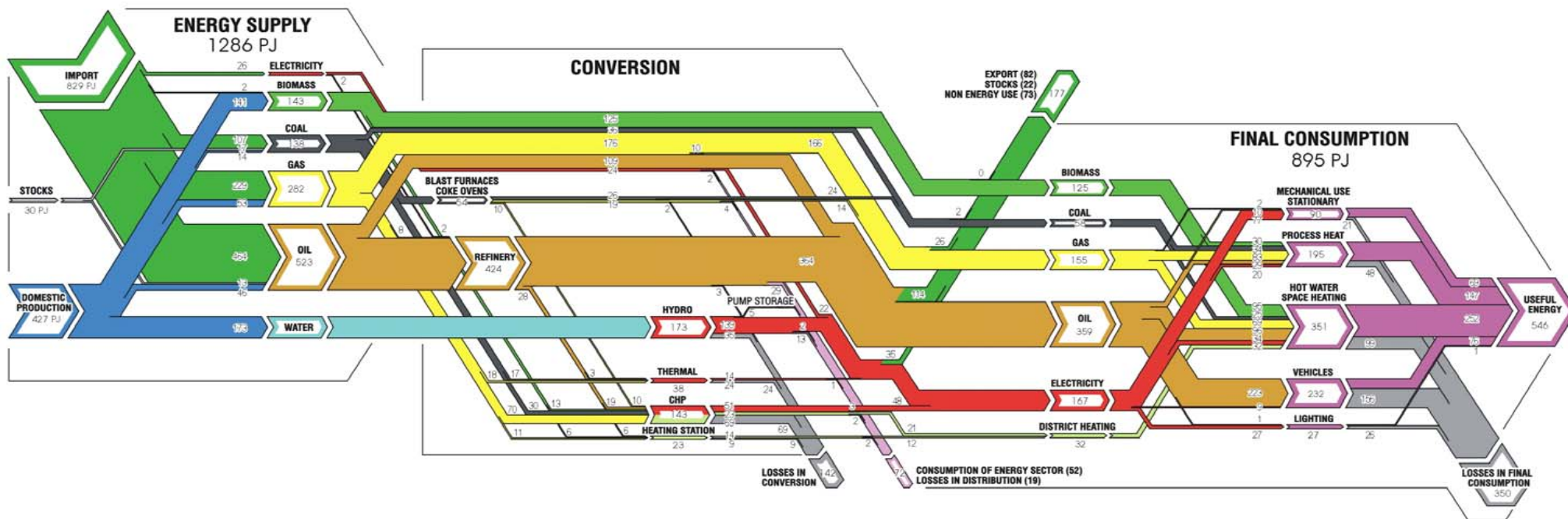

Current Situation CHP Plant in Austria

■ **Traditional:** Biomass CHP application in Pulp & Paper Industry

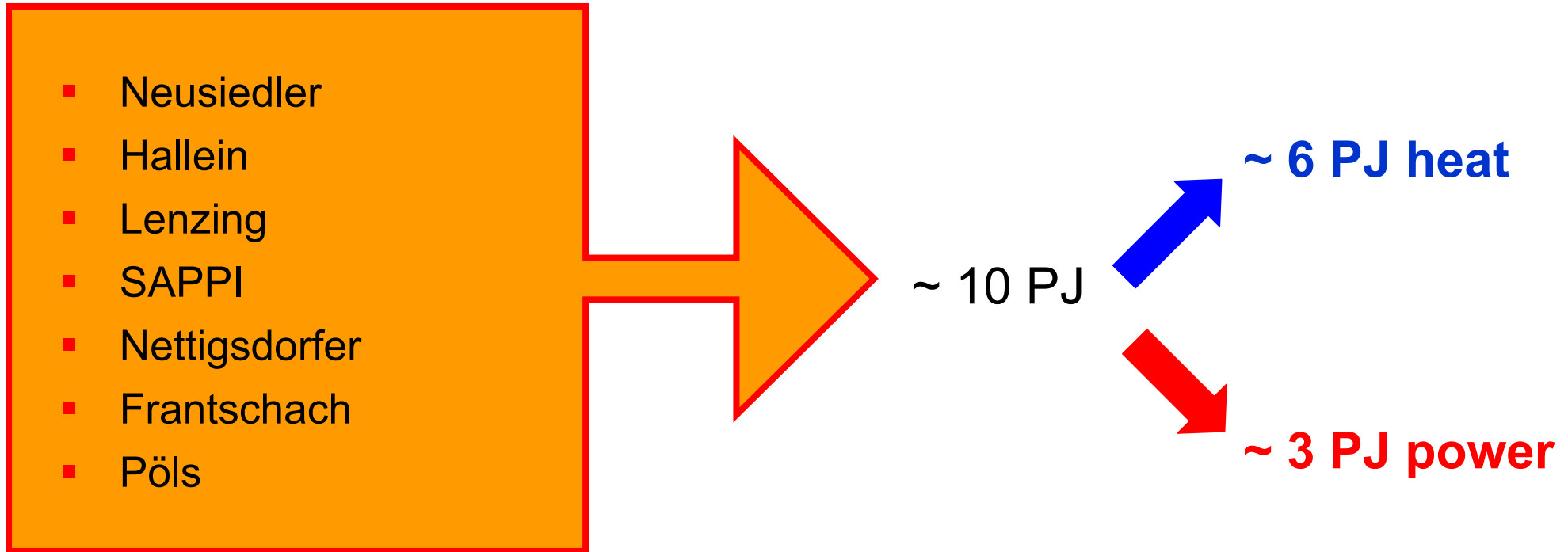

■ **New:** Biomass CHP in Wood Industry and Utility Sector

Principle Scheme of Steam Cycle CHP Plant

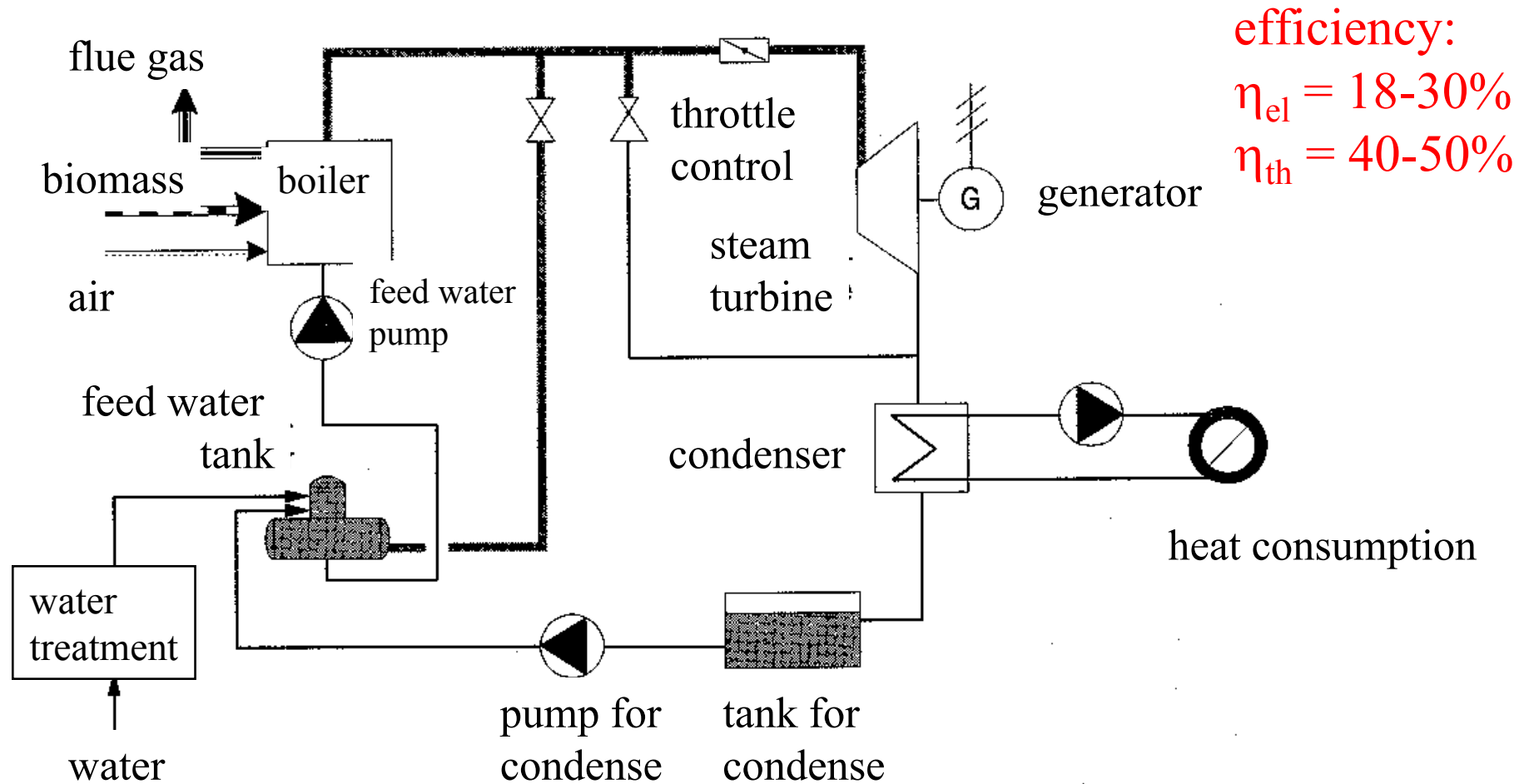

CHP Plant Reuthe (Steam Turbine)



- Conventional steam technology
- solid biomass (chips) 10 000 t/yr
- $6.3\text{MW}_{\text{heat}} / 1.3\text{MW}_{\text{el.}}$
- 4.5 Mio. €

Characteristics CHP Plant Reuthe

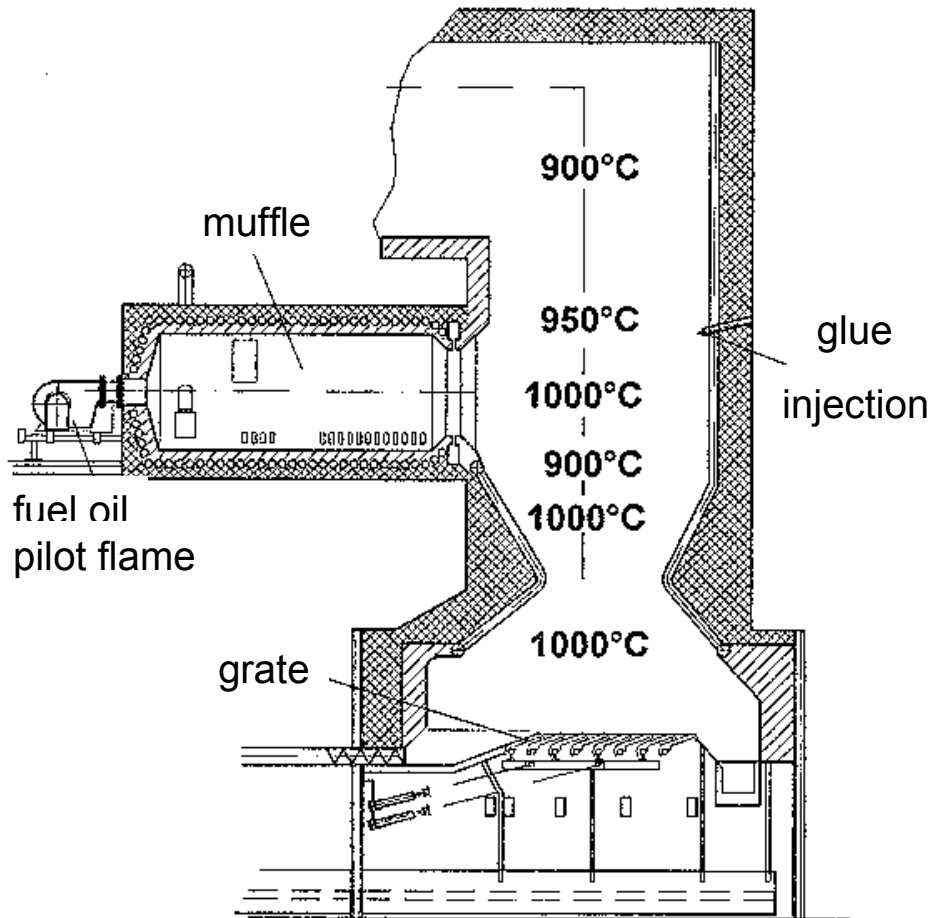

steam: 10 t/h, 32 bar, 445°C
 district heat: 29 GWh/yr, 6.3 MW
 grid electricity: 4.7 GWh/yr, 1.3 MW
 biomass: 10.000 t/yr (70% small
 fuelwood, 30% coarse fuelwood)
 investment: 22 Mio. €

Biomass Fuel Cycle Reuthe

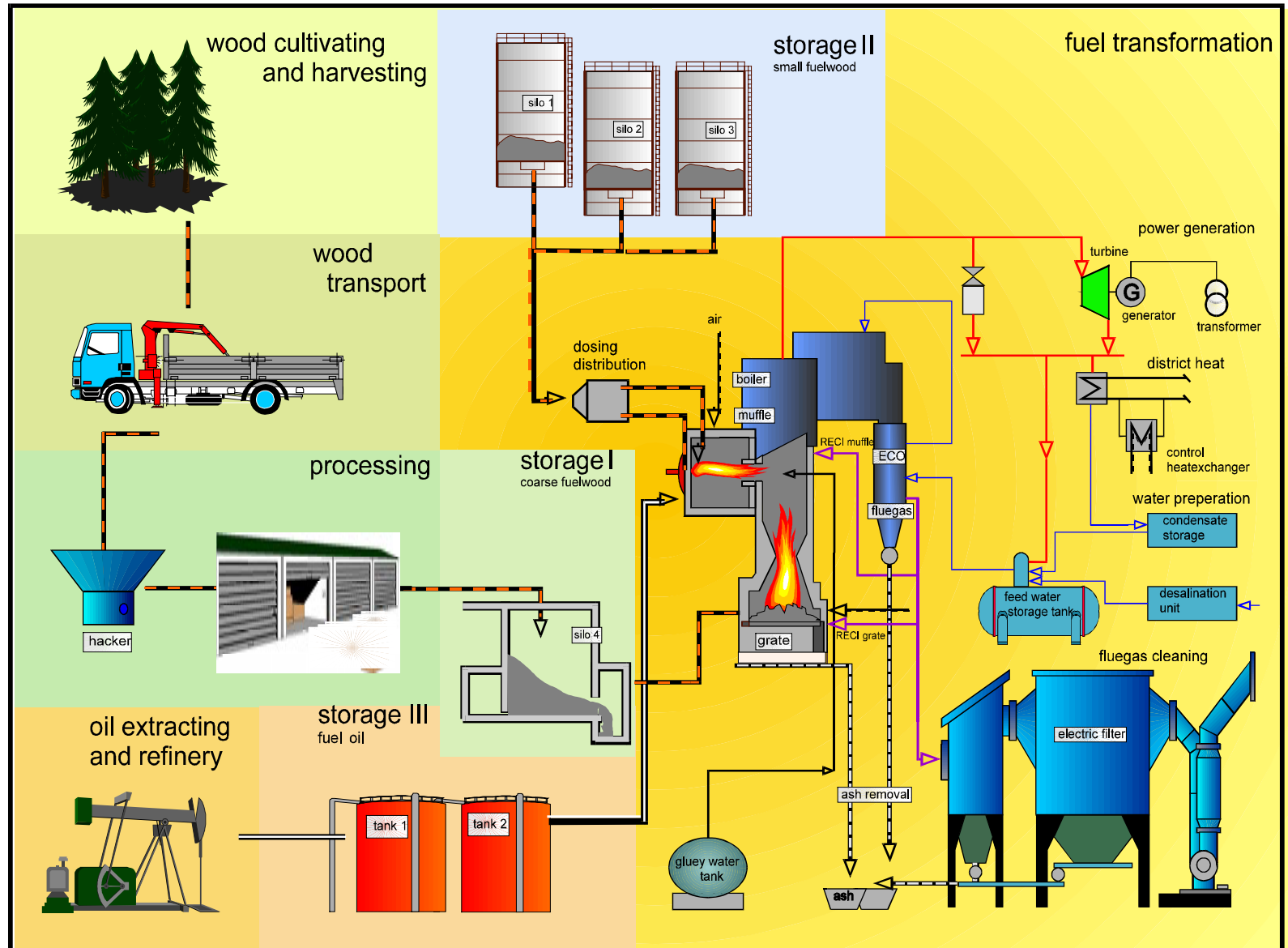

JOANNEUM RESEARCH

System of Combined Heat & Power Plant with Organic Rankine Cycle

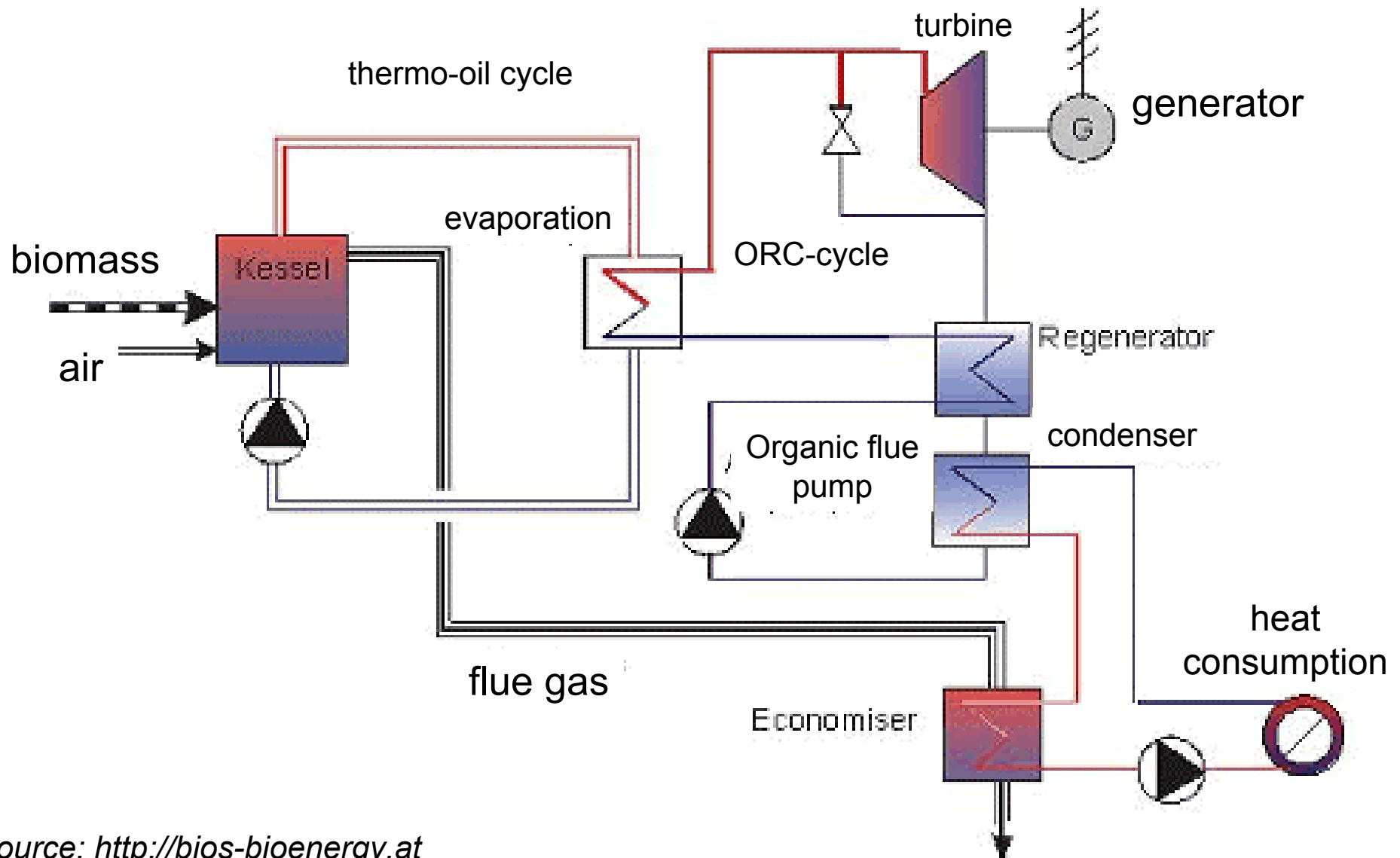

Scheme of Organic Rankine Cycle

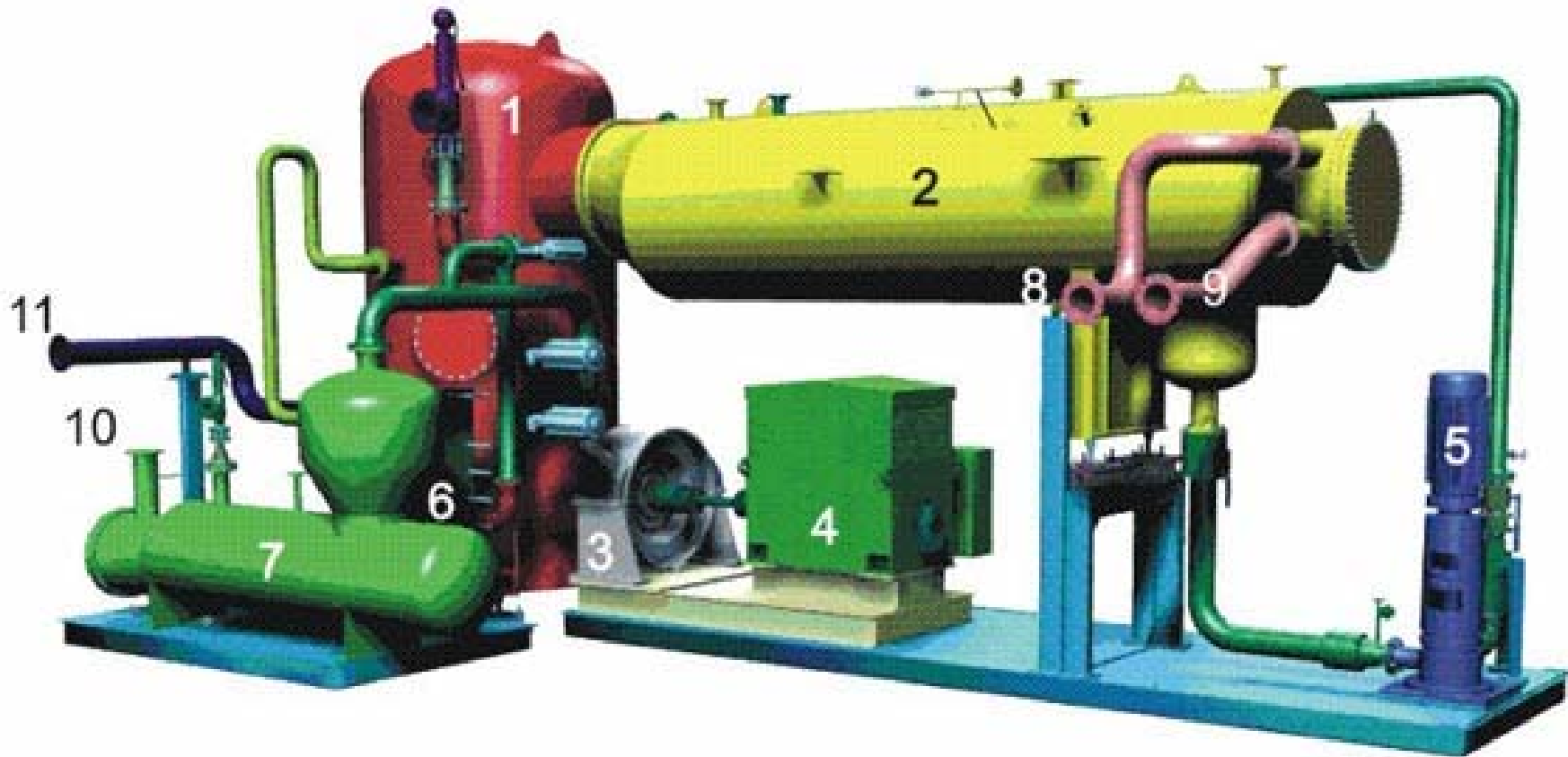

1 regenerator
2 condenser
3 turbine
4 generator

5 pump
6 preheater
7 evaporator
8 district heat output

9 district heat input
10 thermo-oil input
11 thermo-oil output

Energy Flow of Organic Rankine Cycle Module

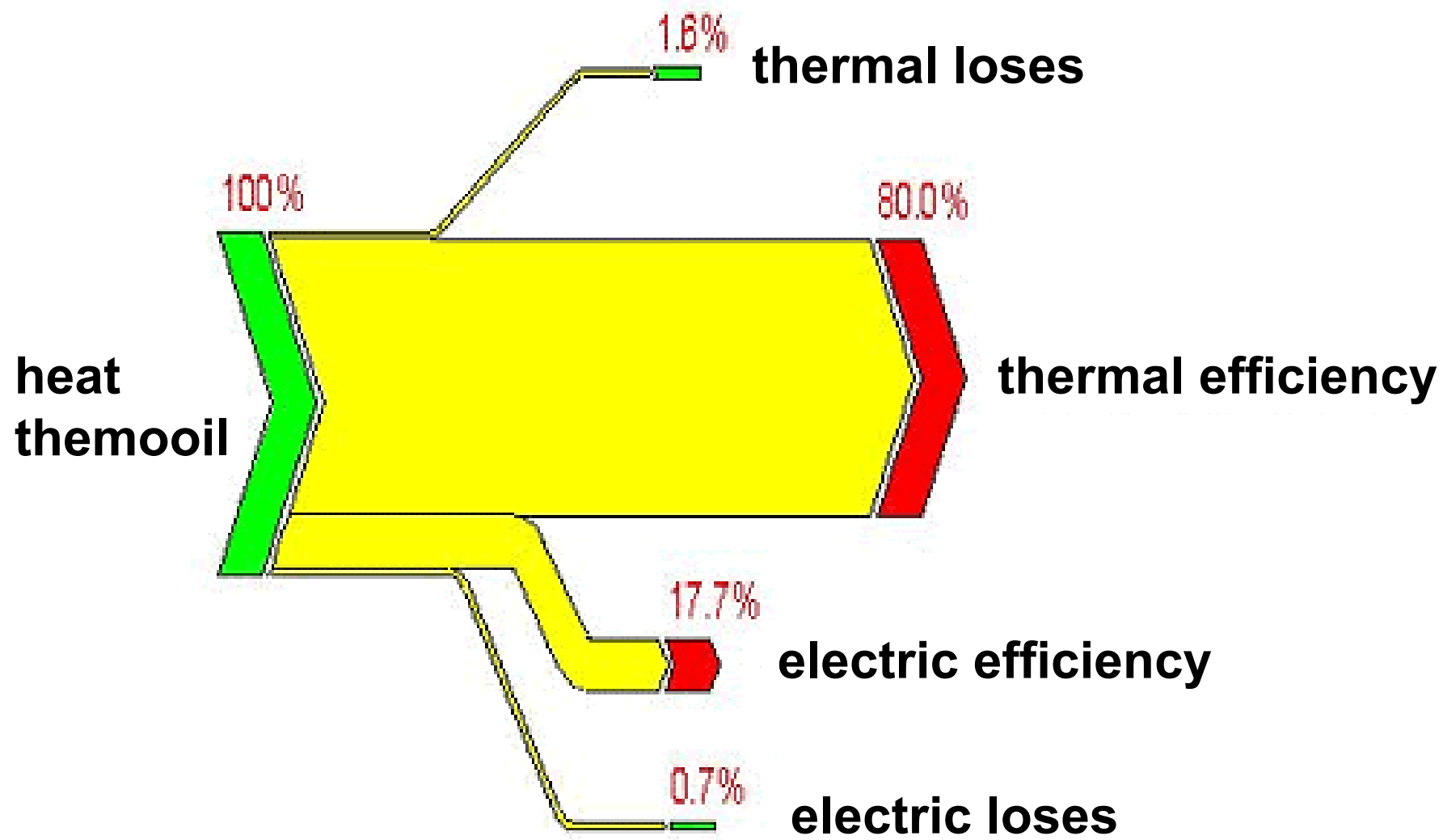

CHP Plant Admont



- Organic Rankine Cycle (ORC)
- solid biomass (chips)
combustion + second thermo-oil
cycle
- $2.7 \text{ MW}_{\text{heat}} / 500 \text{ kW}_{\text{el}}$
- Electricity efficiency 18%

CHP Plant Fussach



- Organic Rankine Cycle (ORC)
- solid biomass (chips) combustion + second thermo-oil cycle
- $5.8 \text{ MW}_{\text{heat}} / 1.1 \text{ MW}_{\text{el}}$
- Electricity efficiency 18%

Biomass Fuel at CHP Plant Fussach



waste wood unprocessed



waste wood processed as fuel

Source: <http://bios-bioenergy.at>

CHP Plant Lienz



- Organic Rankine Cycle (ORC)
- solid biomass (chips) combustion + second thermo-oil cycle
- $7.0 \text{ MW}_{\text{heat}} / 1.0 \text{ MW}_{\text{el.}}$
- Electricity efficiency 18%

Energy flow of CHP Plant Lienz

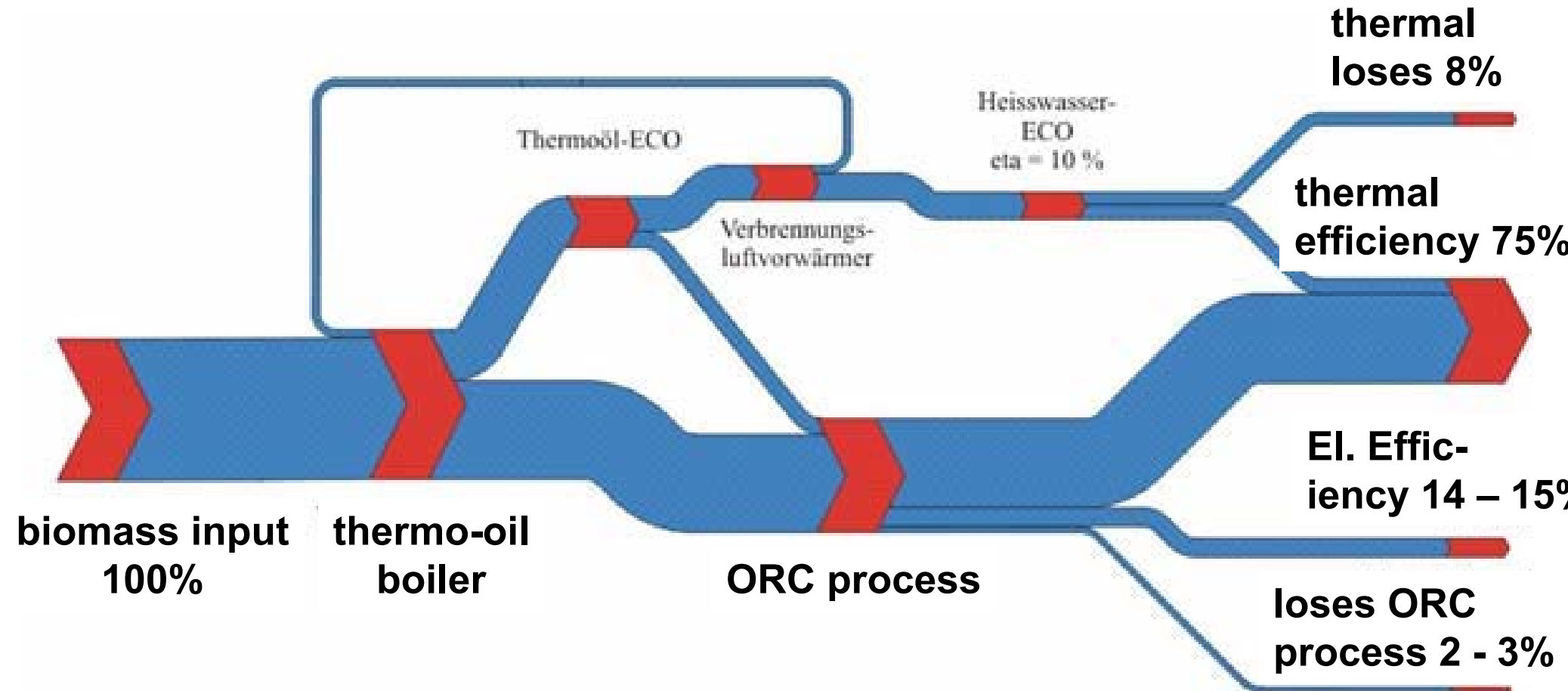

System of Combined Heat and Power Plant with Gas Turbine

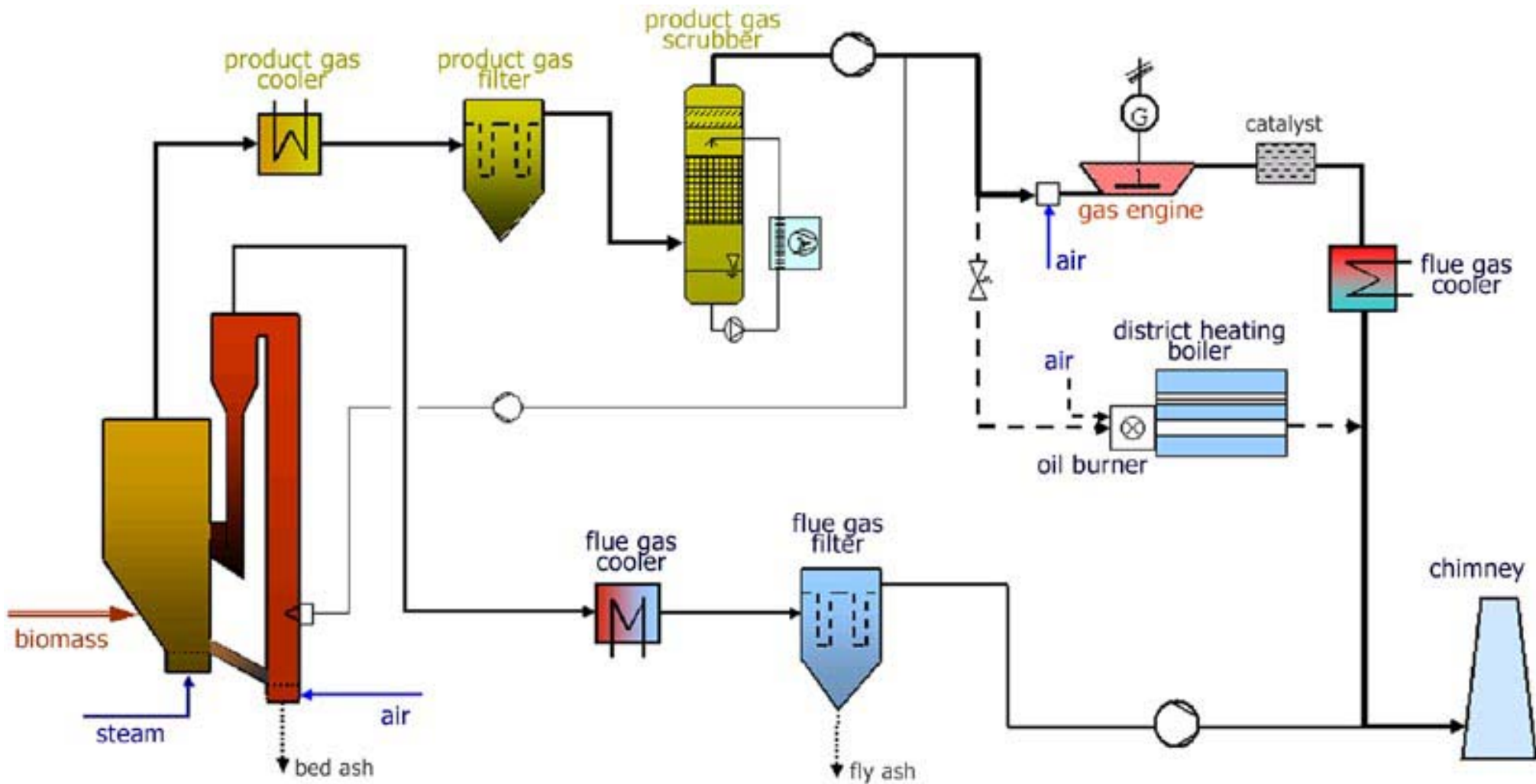

CHP Plant Güssing (Gas Turbine)



- Fluidized bed gasification + gas engine
- solid biomass (chips)
- $4.5 \text{ MW}_{\text{th}} / 2 \text{ kW}_{\text{el.}}$

Co-firing CHP Plant St. Andrä



- Co-combustion of solid biomass (chips) to 124 Mw_{el.} coal fired power plant
- ~5% biomass via grate combustion
- shut down

Co-gasification CHP Plant Zeltweg



- Co-combustion of biomass to 137 MW coal fired power plant
- Co-funding: 4th FP (EU)
- ~5% biomass via fluidized bed gasifier
- shut down

Energy Flow of CHP Plant with Stirling Engine

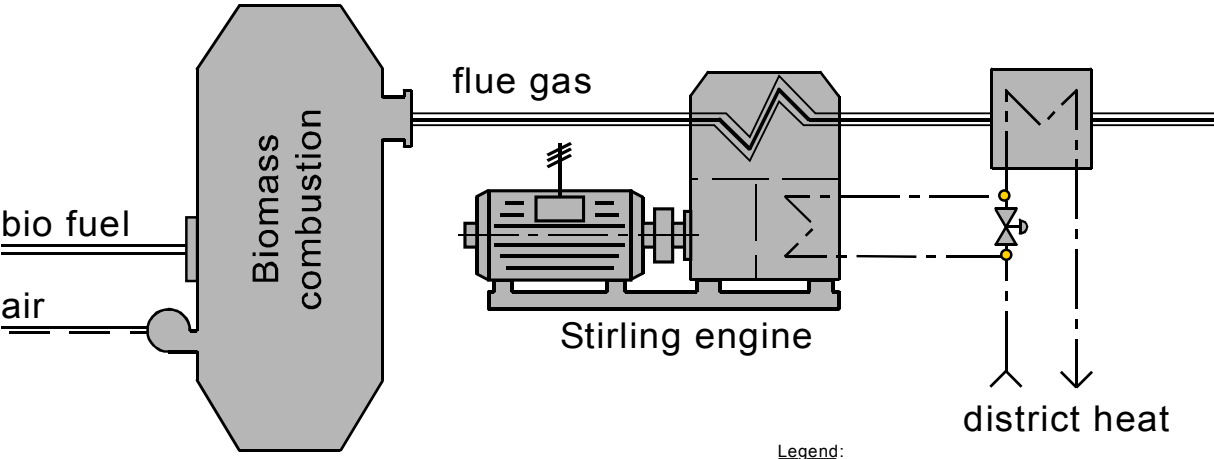

- Legend:
- BB ... Biomass boiler
 - BF_{in} ... Biomass fuel
 - DH ... District heating
 - EG ... Elec. generator
 - ELP ... Elec. power
 - FG ... Flue gas
 - HE ... Heat exchanger
 - L ... Losses
 - SHP ... Shaft power
 - STE ... Stirling engine

$$\eta_{STE} = \frac{SHP}{Q_{KW} + SHP}$$

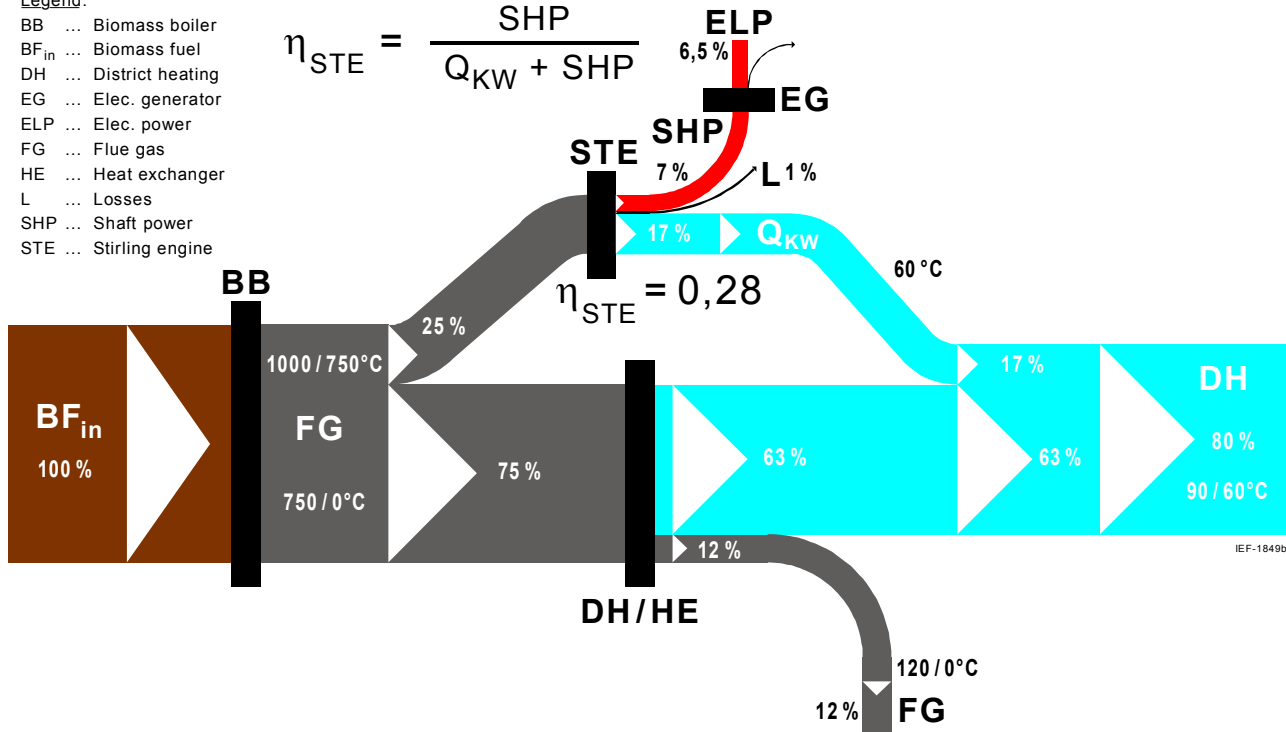

System of Combined Heat and Power Plant with Stirling Engine

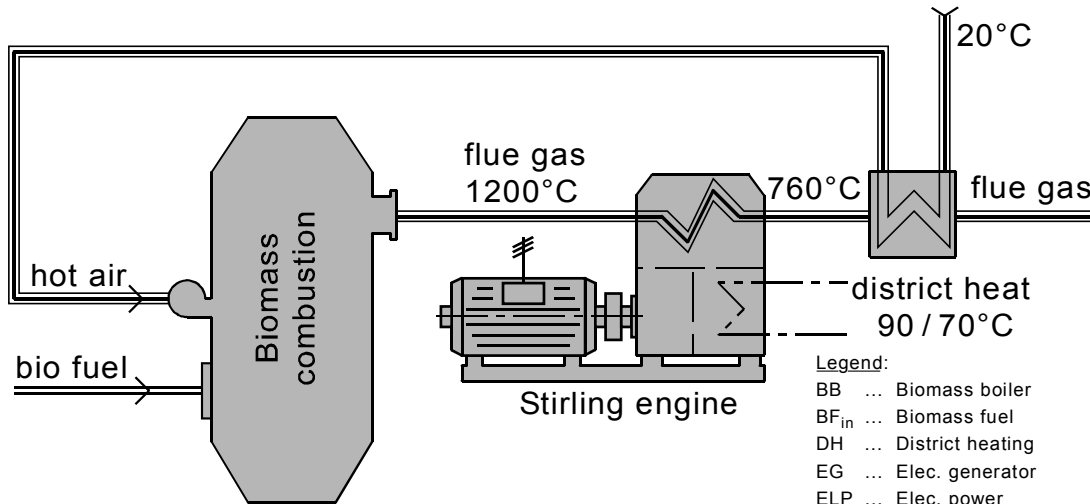

- Legend:
- BB ... Biomass boiler
 - BF_{in} ... Biomass fuel
 - DH ... District heating
 - EG ... Elec. generator
 - ELP ... Elec. power
 - FG ... Flue gas
 - HE ... Heat exchanger
 - HR ... Heat recovery
 - L ... Losses
 - SHP ... Shaft power
 - STE ... Stirling engine

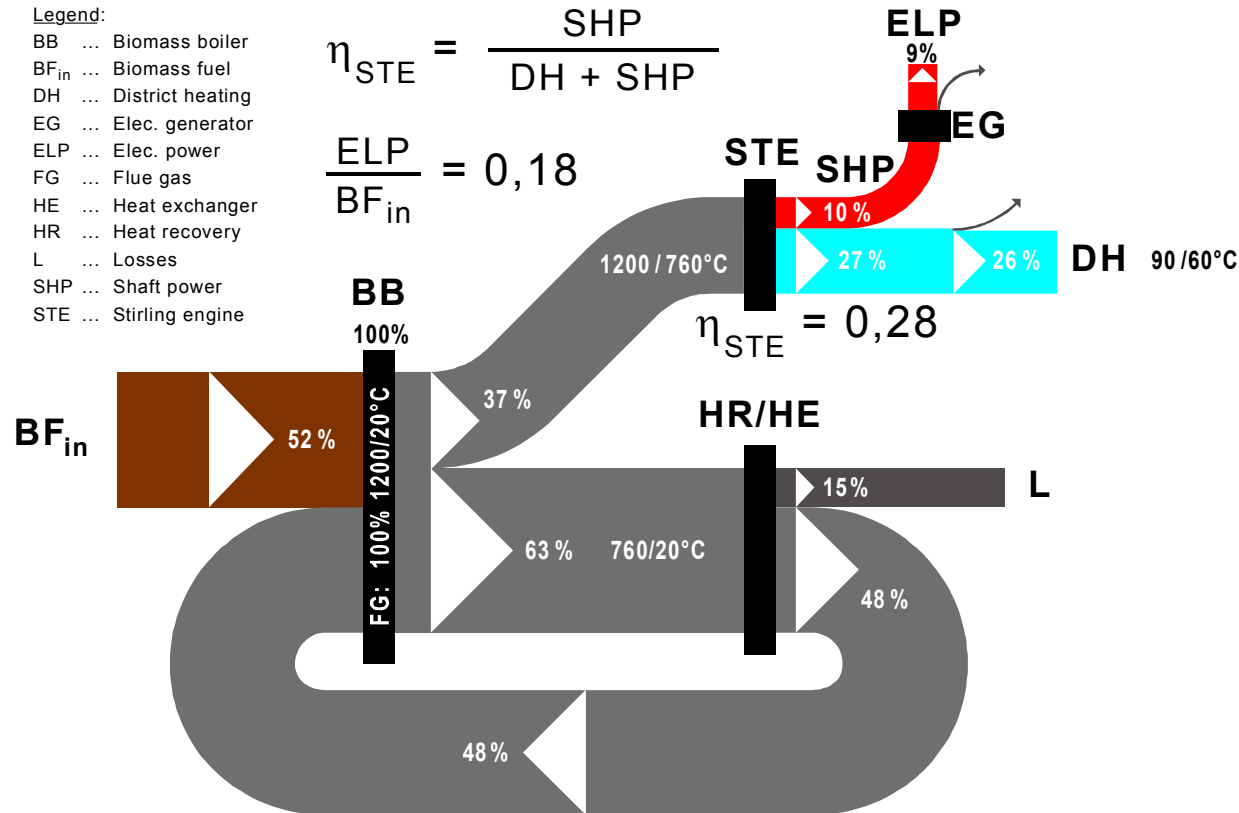

CHP Plant Hartberg (Stirling Engine)

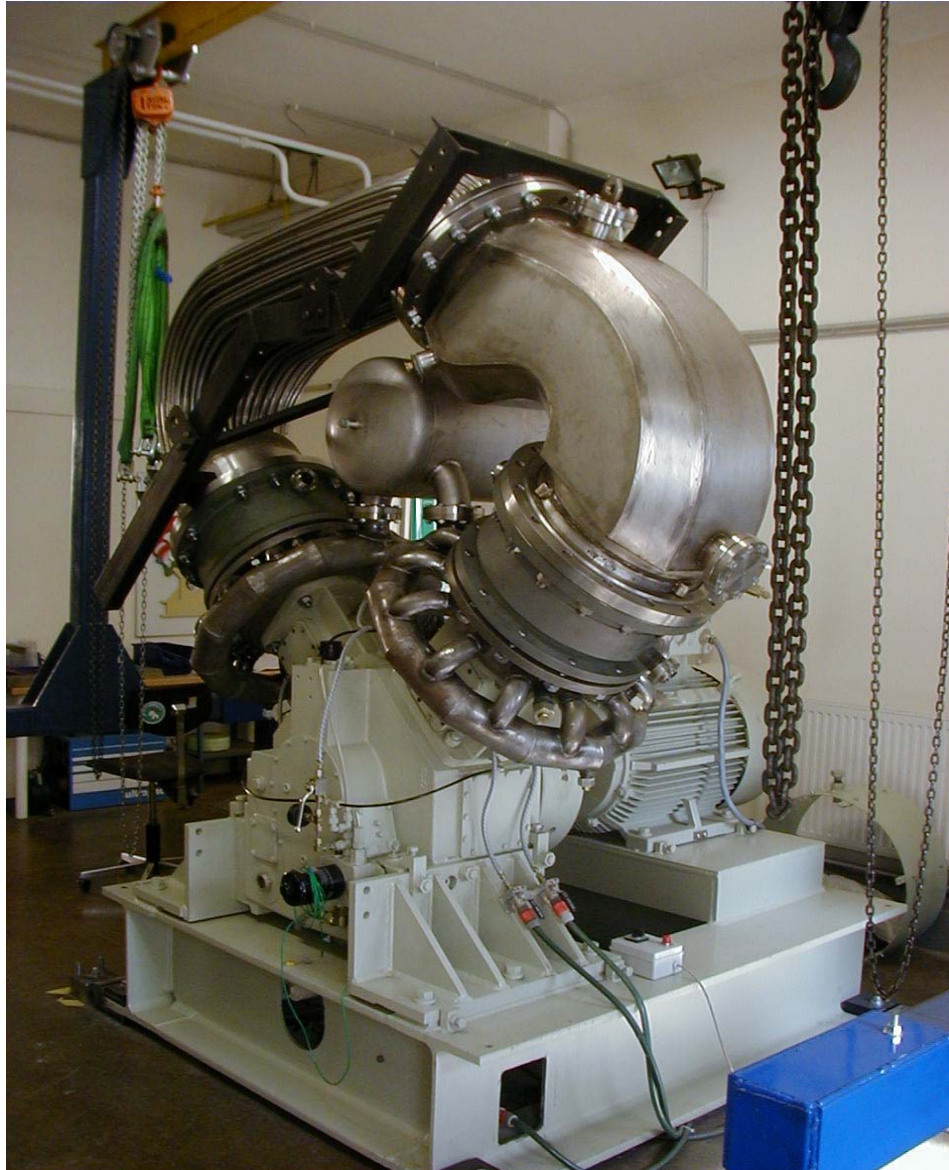

- Stirling Engine
- solid biomass (chips)
- $0.5-3 \text{ MW}_{\text{heat}}$
 $20-100 \text{ kW}_{\text{el.}}$

Conclusions

- **CHP with biomass small role in Austrian energy system**
- **Most important: existing CHP plants in pulp & paper industry**
- **Some demonstration plants with different technologies**
- **Steam cycle: commercially available**
- **Organic Rankine cycle: good experiences**
- **Gasification with gas engine: excellent experiences**