

Bio-composites based on forest derived materials and biodegradable polymers

Dr. Patrizia Cinelli

Prof. Andrea Lazzeri



Department of Industrial Chemistry, Chemical Engineering and Materials Science of the University of Pisa, Italy

patrizia.cinelli@diccism.unipi.it

a.lazzeri@diccism.unipi.it



**“Niche markets for specialty industrial crops”
2 September 2011 Thessaloniki, GREECE**





The FORBIOPLAST project

“Forest Resource Sustainability through Bio-Based-Composite Development” is a collaborative Large-scale European Project in the 7th Framework Programme. KBBE-2007-3-1-04: FOREST PRODUCTS - New forest based products and processes

GOALS

- ✿ Valorisation of forest resources for the production of biobased products.**
- ✿ Identification of the best ways for industrial exploitation of forest biomass at the European scale.**
- ✿ Development of improved technologies with regard to the present industrial synthesis of polyurethane and target of an industrial scale up of the process.**
- ✿ Replacement of glass fibres and mineral fillers with wood derived fibres in automotive interior and exterior parts.**
- ✿ Development of biodegradable polymer/wood derived fibre composites for application in the packaging and agriculture sector.**
- ✿ Production of polyurethane from materials based on forest resources.**



Participants in FORBIOPLAST

The FORBIOPLAST consortium is composed of 16 partners. All the research activity is carried out in strict cooperation among research centres, small-medium enterprises and industrial partners in order to develop valuable products.

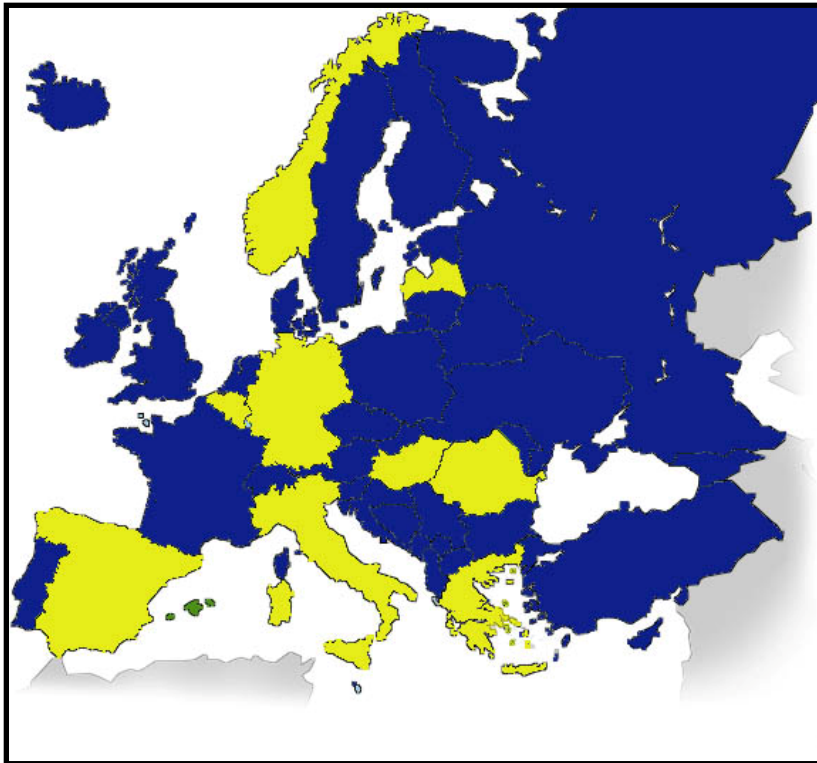

Researchers

- University of Pisa (Italy): coordinator, nanotechnology, material processing
- University of Budapest (Hungary): fibres modification
- Latvian State Institute of Wood Chemistry (Latvia): PU expert
- University of Almería (Spain): biovalorisation, biodegradation
- Fundacion CARTIF (Spain): forest material expert
- University of Agronomic Sciences and Veterinary Medicine, Bucharest (Romania): agriculture, toxicity
- Organic Waste Systems (Belgium): composting, LCA
- Norconserv A.S. (Norway): packaging tests

Producers

- PEMŰ Plastic Processing Co. (Hungary): car components, packaging
- RODAX (Romania): equipment
- Ritols Ltd. (Latvia): PU foams
- Incerplast (Romania): packaging

End users

- FIAT Research Center (Italy): vehicle prototypes, LCA on car components
- Neochimiki L.V. Lavrentiadis S.A. (Greece): users and tests on packaging
- Cosmetic (Greece): users and tests on packaging

Market expert

- Wiedmann GmbH. (Germany)



Applications

Expected products

- Car seat
- Biodegradable plant pot
- Substitute of lightweight expanded clay aggregate
- Tomato clip
- Encapsulated fertilizer
- Packaging (container for cosmetics, chemicals, fish, transport of fish, biological egg)

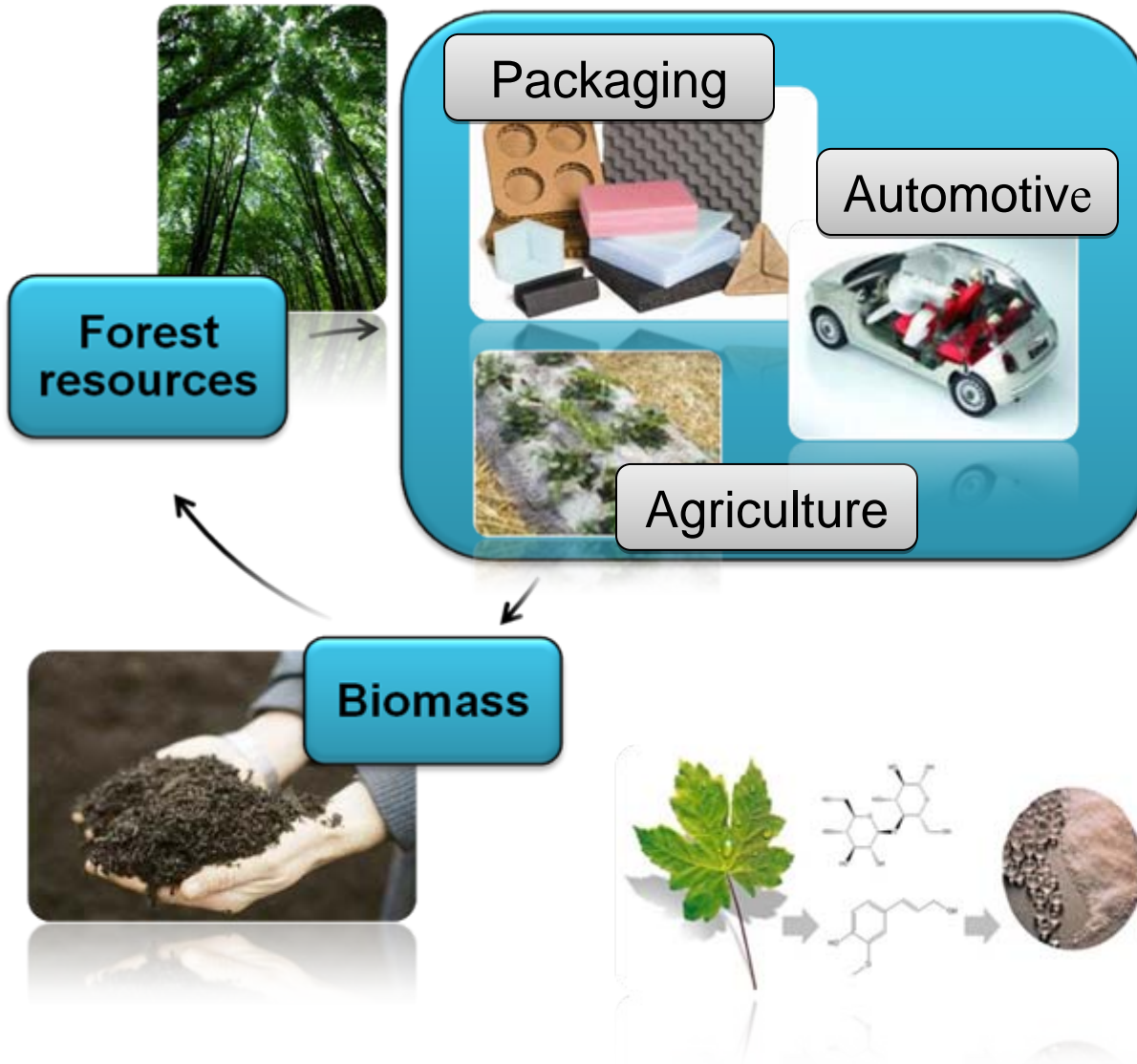



Applications



T-bone and spoiler for automotive by IWC, PEMU and CRF
25% renewable material



Soft PU foams by UNIPI with lignin content from 6% to 13% and total content of renewable material over 40%

The approach to production of wood Composites

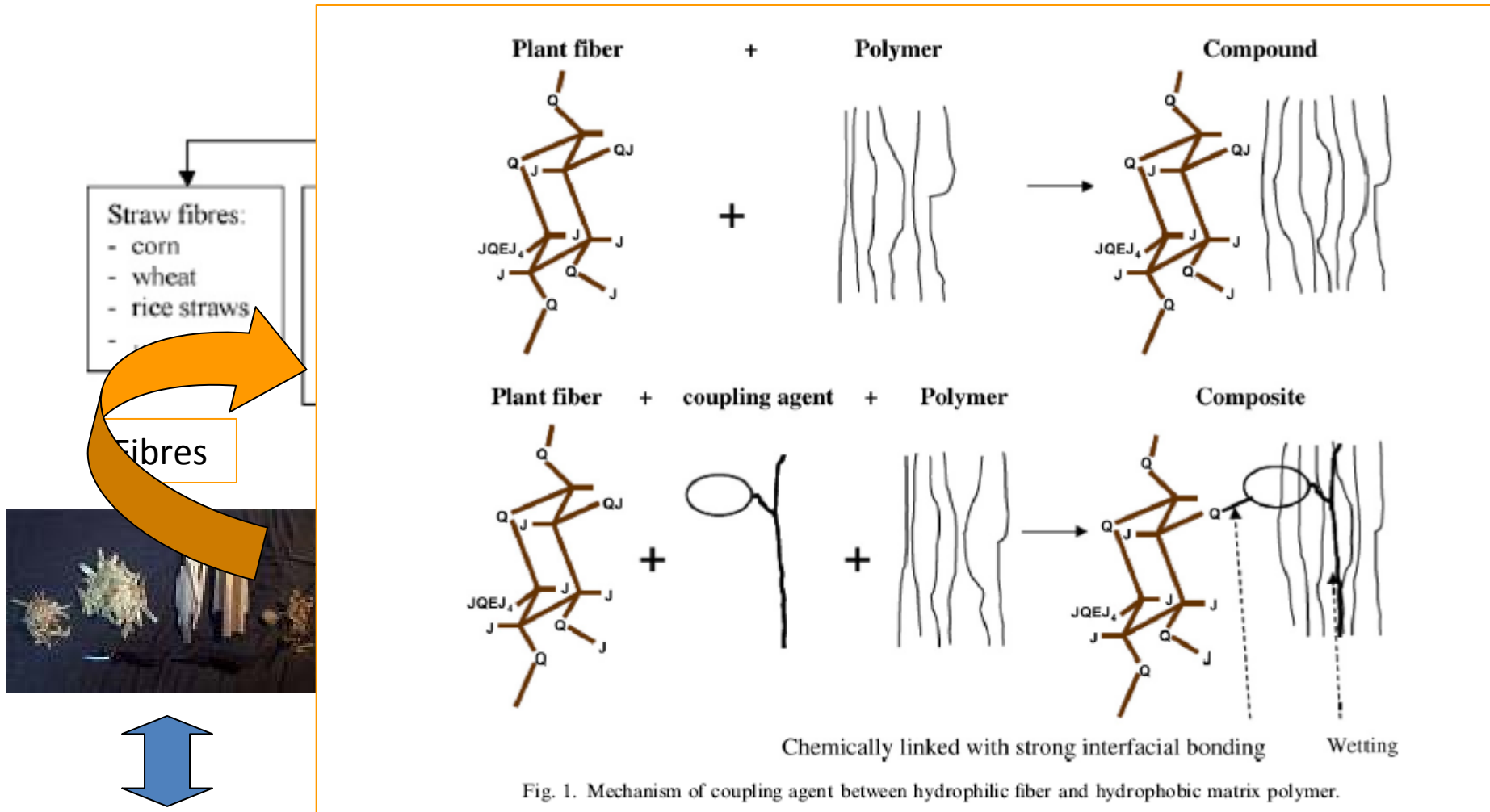

Modification

Ashori, A., *Wood-plastic composites as promising green-composites.*, *Bioresour. Technol.* (2007)

Composites with Natural Fibres in Automotive Applications

Wood plastic composites market (2002)

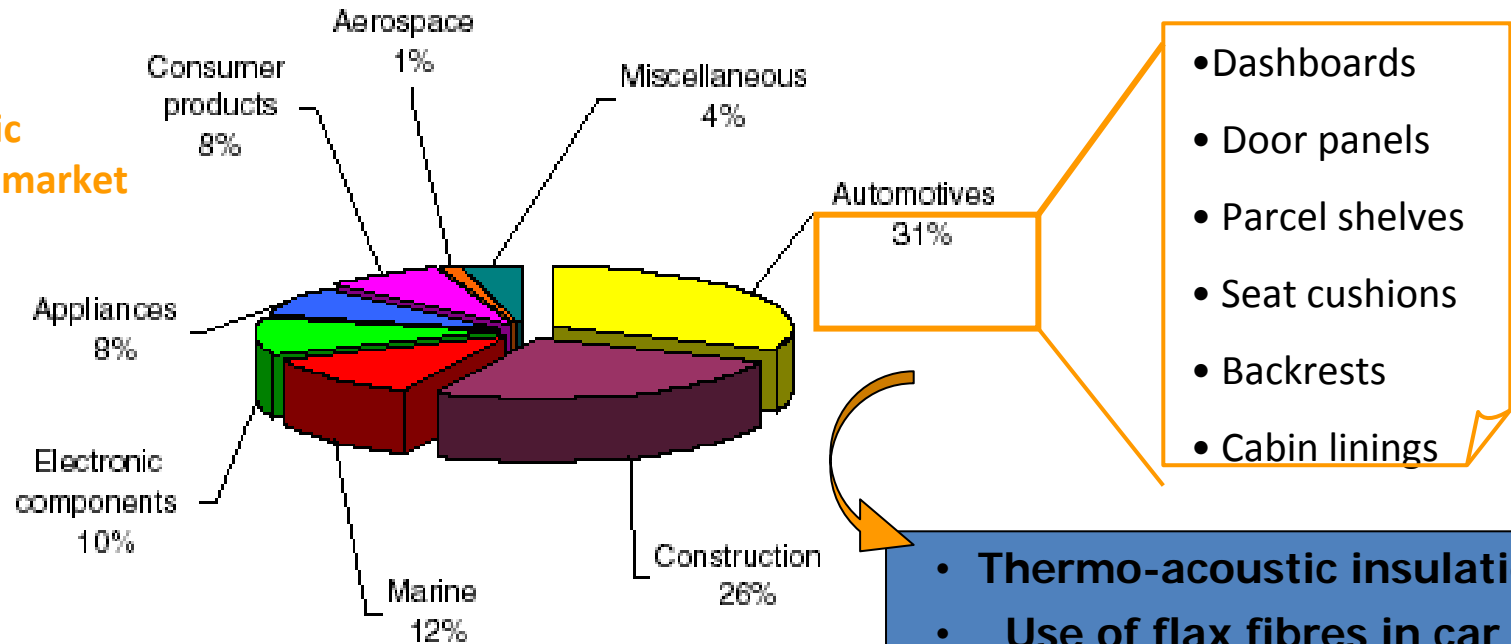

Fig. 2. Wood plastic composites used in 2002.

Growth in the European wood-plastic composites market averaged 23% per year 2003 and 2007. This means that the market grew in that period TEN TIMES as fast as the plastics industry as a whole in this region, although rates do vary by country and by polymer.

We target the use of recycled PP, thus providing an additional positive impact for the environment.

FIAT will be happy to be able to use its recycled PP for the production of composite parts in their vehicles with positive economic, and environmental impact. Moreover the possibility to work with pre-treated fibres in the form of pellets (instead of the use of powdered fibres) will be safer for the workers and for the extruders.

Packaging by Renewable Resources

In Europe 30-50 % of plastics are used for packaging.

The Directive on Packaging and Packaging Waste contains provisions for the prevention of packaging waste, the re-use, the recycling and recovery of packaging material. Consequently there is an increasing pressure on the packaging industry to develop environmentally sustainable materials, either by recovery, recycling or biodegradation.

Packaging suppliers have stepped up their research in the production and use of **biodegradable packaging**. They need to use renewable packaging materials with enhanced properties such as improved functionality, higher flexibility and improved mechanical as well as barrier properties. Industries have identified targeted applications related to the packaging of detergents, pharmaceuticals, cosmetics and fertilisers.

New materials derived from renewable resources which were developed by Pisa University as **natural fibre based composites** will be used for packaging of detergents (polymers with natural fibres which will be by-products of agriculture, wood-industry, paper mills) and fertilisers.



COMPOSITES

PLA/ECOFLEX

50:50

LIGNIN 5%-20%

LA SOLE 15%-20%-30%

20:80

RETTENMAIER-EFC1000 15%20%

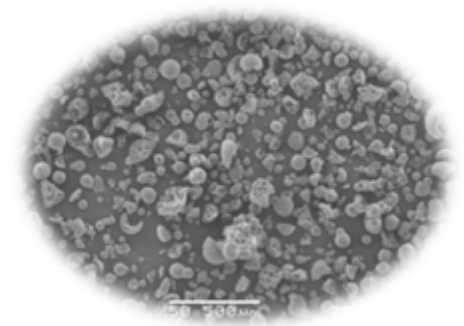

Haake mini extruder



PHB



PEG
as plasticizer(15%-20%)

LA SOLE 15%-30%

RETTENMAIER-EFC1000

15%-20%-30%

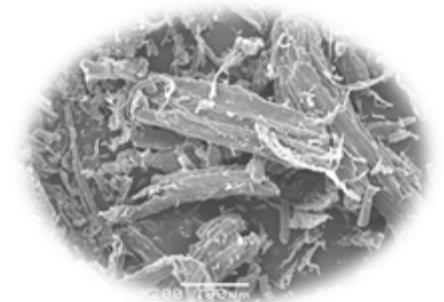

Pilot Scale Extrusion



The COMAC co-rotating twin screw extruder EBC 25HT

CHARACTERIZATION

DMTA

-100..140°C

2 °C/min

1 Hz



IMPACT TEST

ASTM standard method D6110

TENSILE TEST

ASTM standard method D638

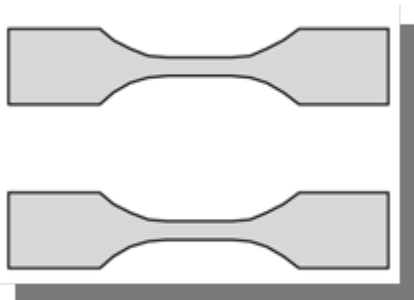

FT-IR

TGA

SEM

DSC

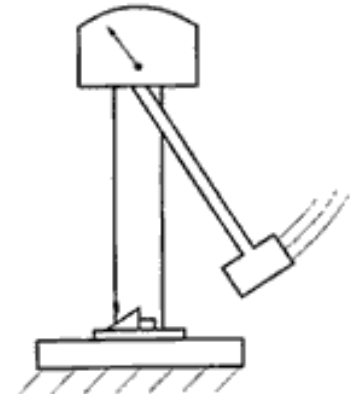

CHEMICAL MODIFICATION OF WOOD

ACETYLATION

Acetic Anhydride

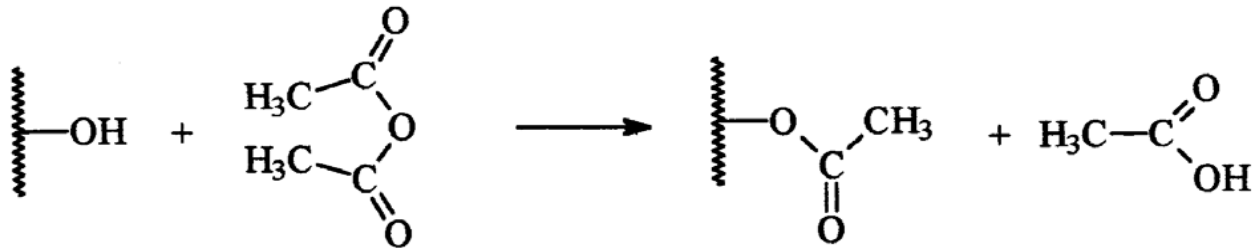

Formation of covalently bonded groups in wood and formation of acetic acid as by-product

Esterification of the accessible hydroxyl groups in order to reduce the absorption of water

HYDROPHILIC WOOD + HYDROPHOBIC PLASTIC

CHEMICAL MODIFICATION OF WOOD

Degree of acetylation

Weight percent gain \longrightarrow $(\text{weight gain}/\text{original weight}) \times 100$

ACETYLATION	WPG (%)	TIME (min)
1	7.35	105
2	12.26	60
3	16.18	120
4	15.8	150
5	14.1	135
6	15.48	120
7	19.88	135

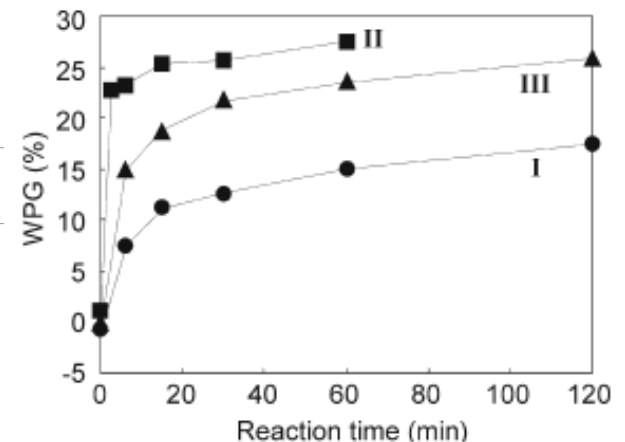
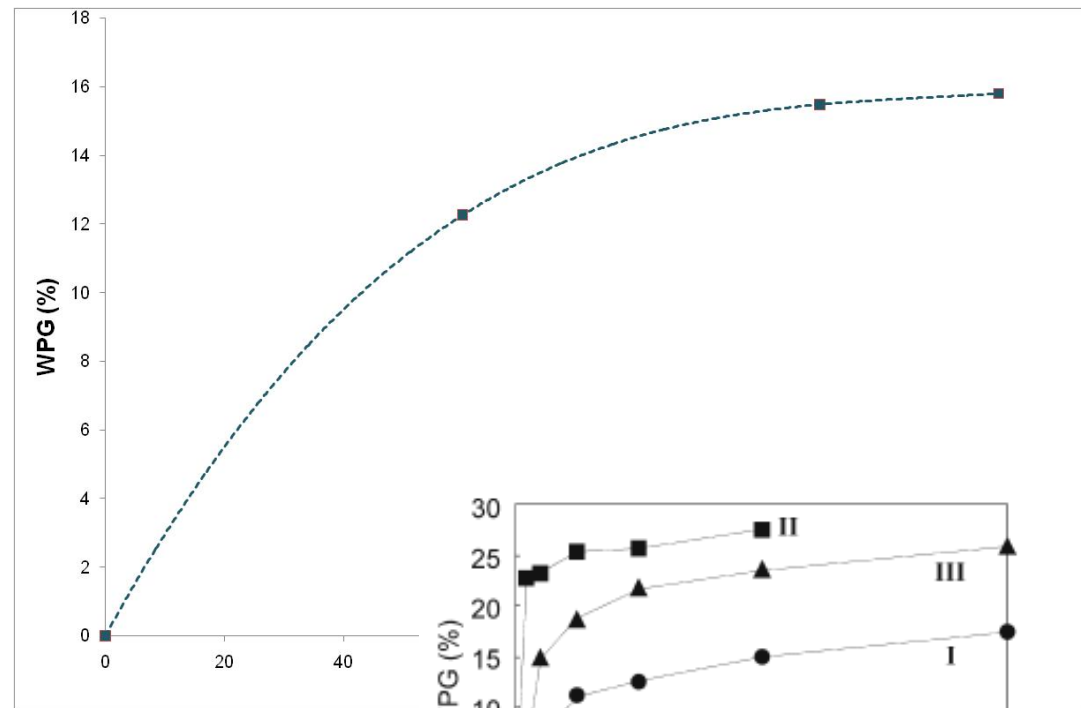

Eiichi Obataya · Kazuya Minato

"Potassium acetate-catalyzed acetylation of wood at low temperatures I: simplified method using a mixed reagent"

J Wood Sci (2009) 55:18–22

CHEMICAL MODIFICATION OF WOOD

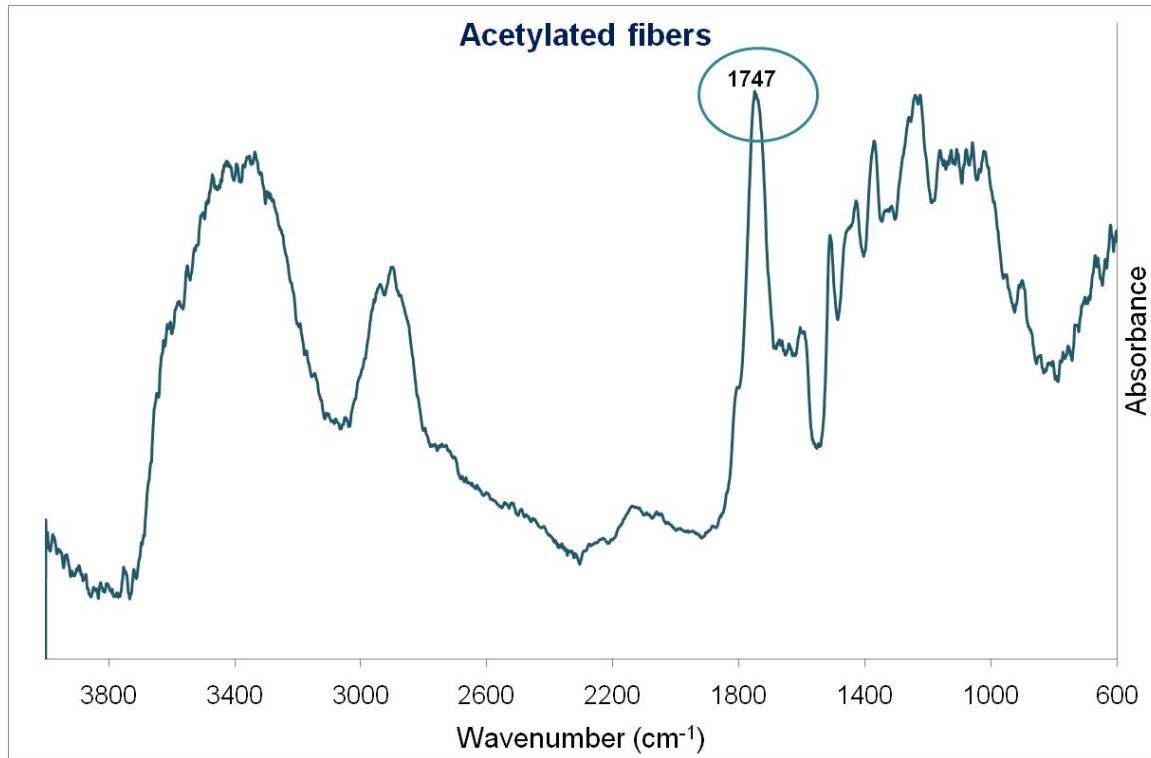

1735-1750 C=O stretching of carboxylic ester

C=O stretching of acetyl groups in hemicelluloses decreases at the increased degree of acetylation.

Rettenmaier (EFC-1000)

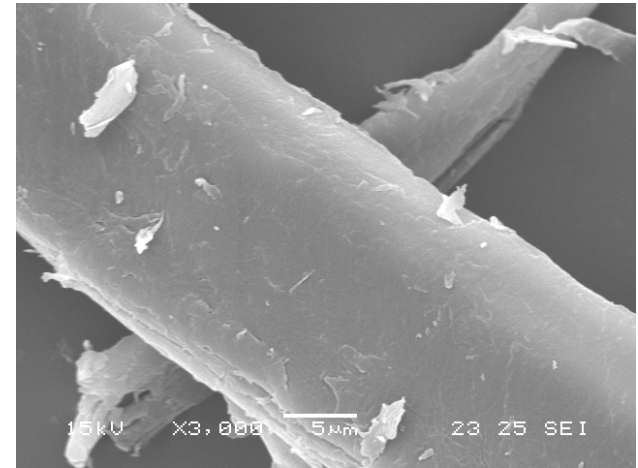

Acetylated wood fibers

WPG=12.26%

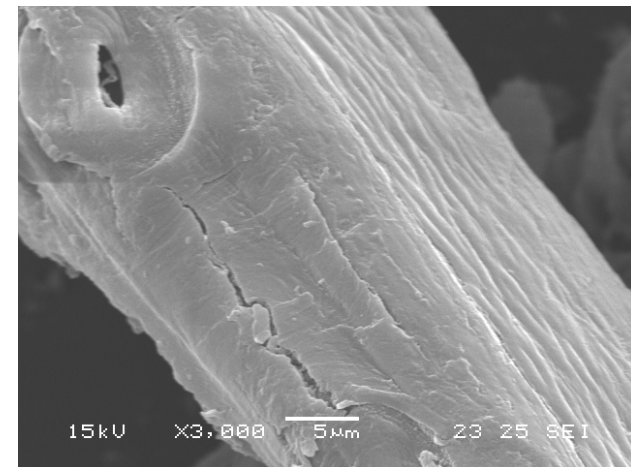

PLA/Ecoflex/Rettenmaier fibres

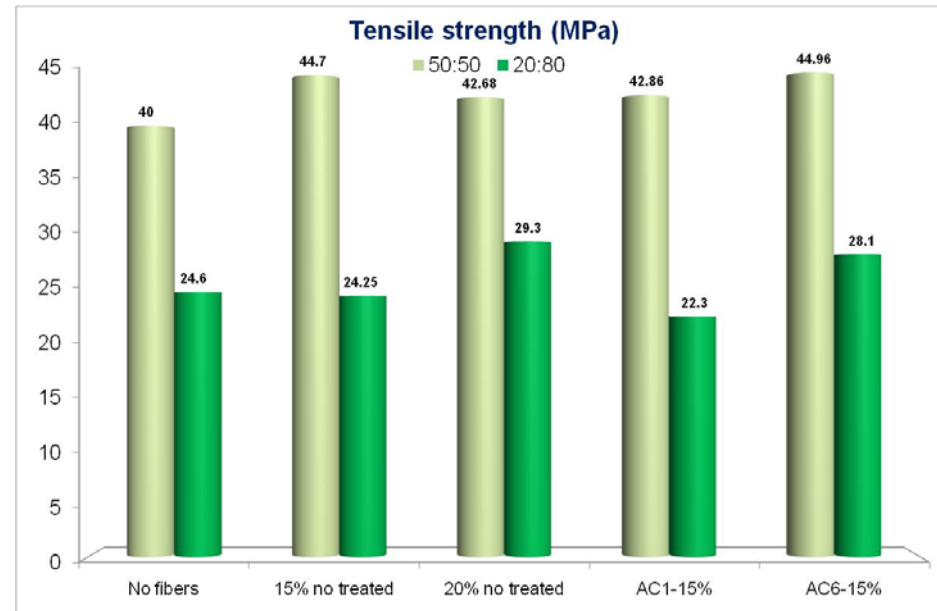
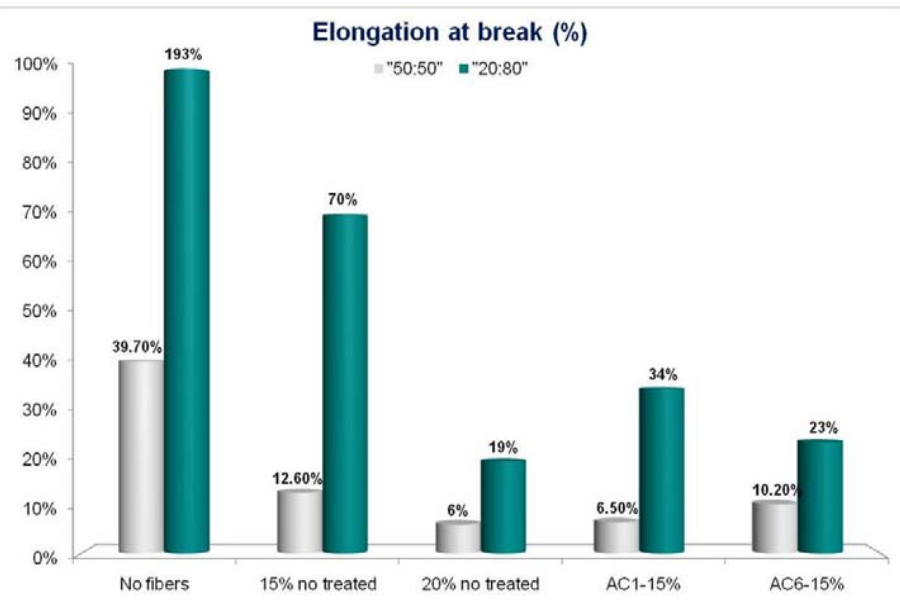
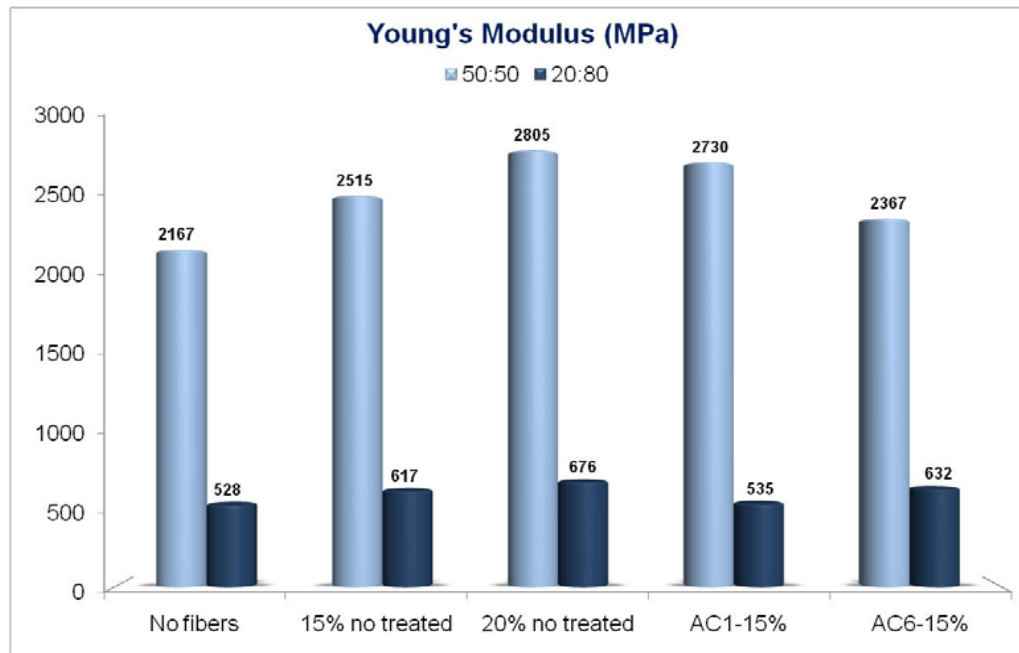

PLA/Ecoflex/Rettenmaier fibres

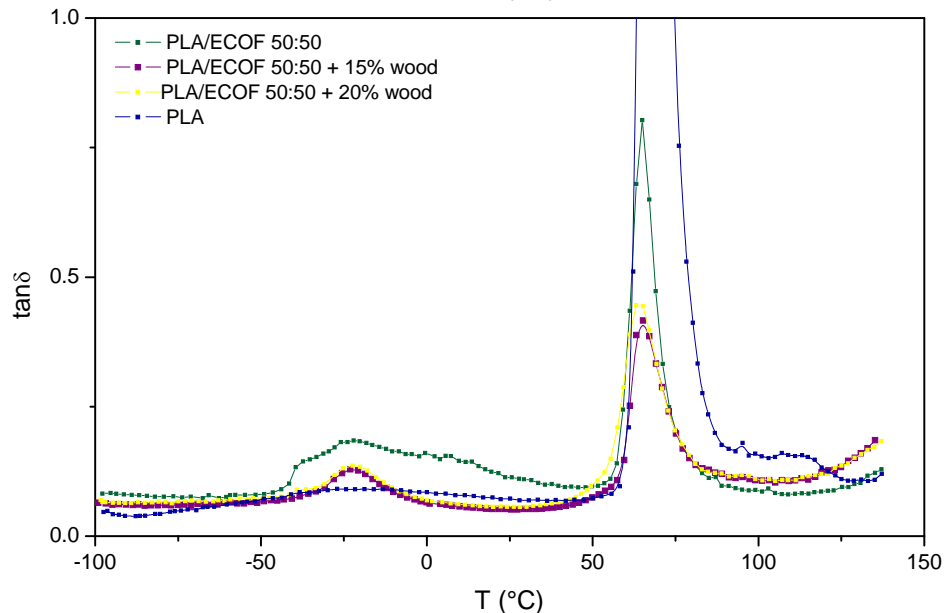
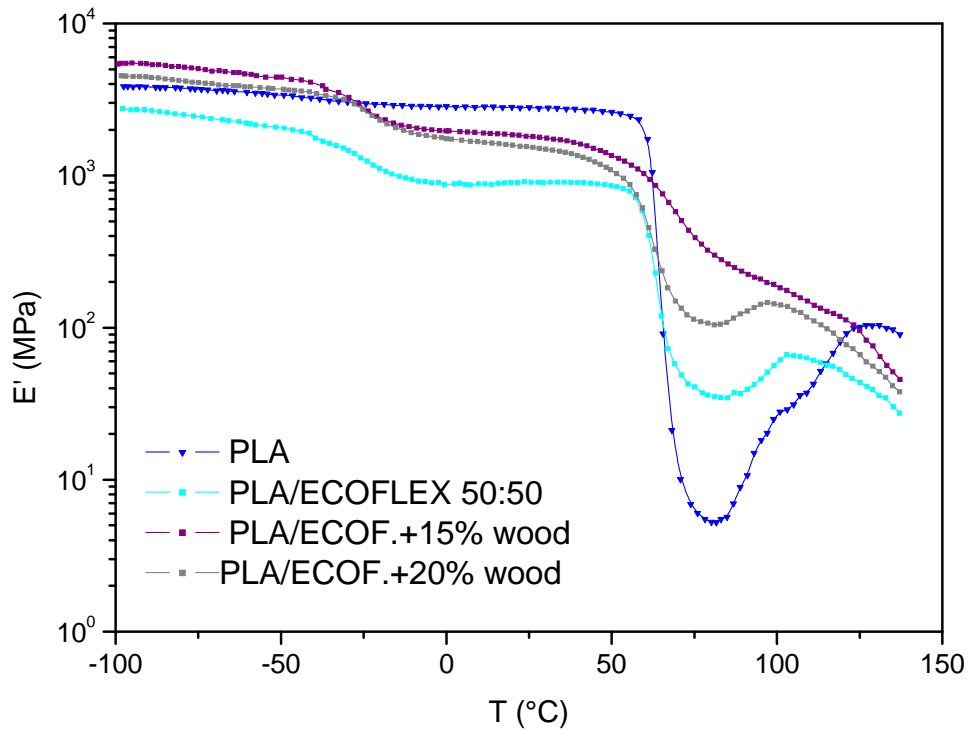

	$T_g(^{\circ}\text{C})$
PLA	68
PLA/ECOFLEX 50:50	65
PLA/ECOF. + 15% WOOD	65
PLA/ECOF. + 20% WOOD	63

PHB/PEG/Wood Fibres

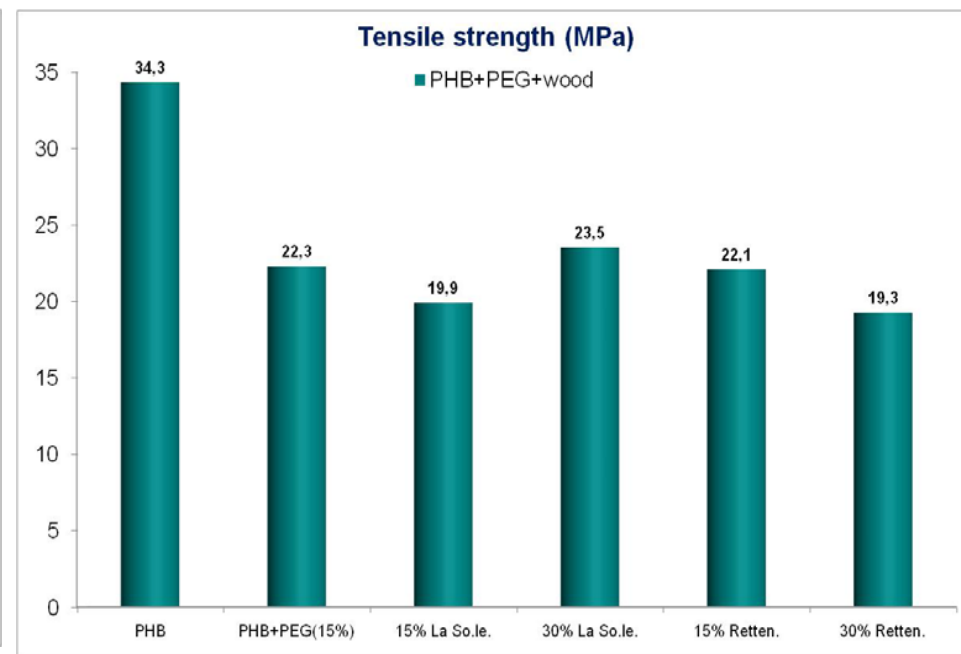
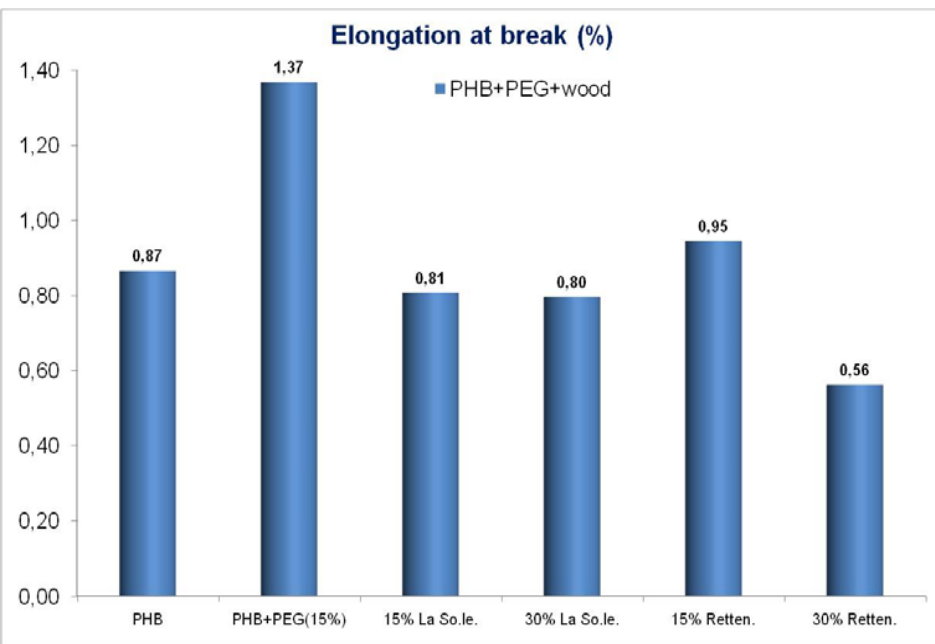
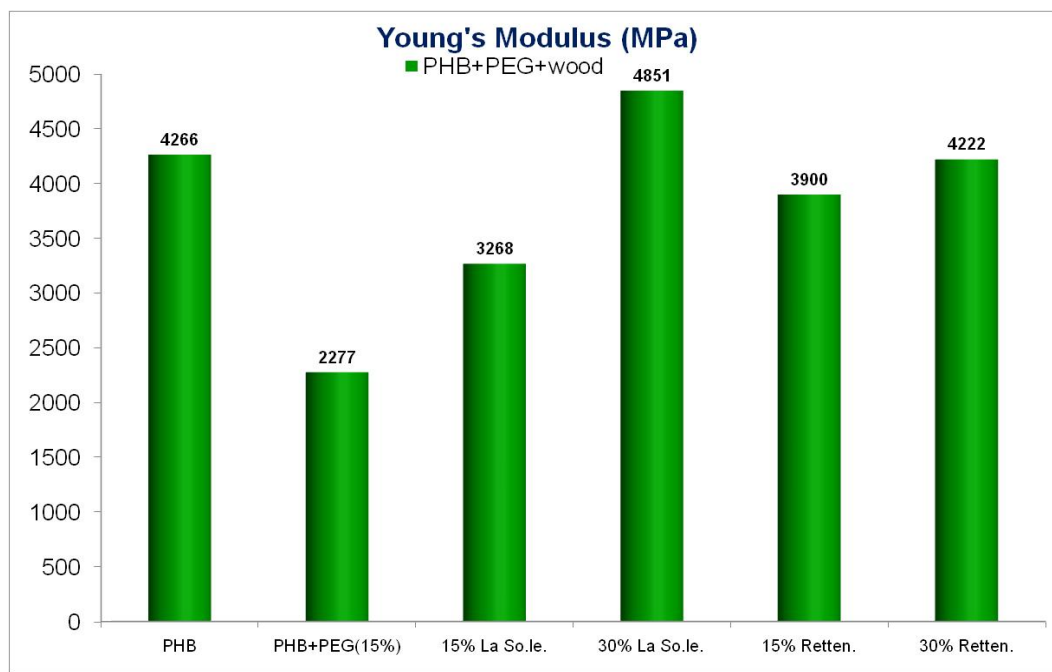

COMPARISON DIFFERENT TYPES OF FIBRE

15% fibers		La So.Le.	Rettenmaier	Acetylated1	Acetylated6
YOUNG'S MODULUS (MPa)	PLA/ECOF50:50	2280	2515	2730	2367
	PLA/ECOF20:80		617	535	632
	PHB	3268	3150		
ELONGATION AT BREAK (%)	PLA/ECOF50:50	10%	12.60%	6.50%	10.20%
	PLA/ECOF20:80		70%	34%	23%
	PHB	0.81%	0.95%		
TENSILE STRENGTH (MPa)	PLA/ECOF50:50	41.71	44.7	42.9	45
	PLA/ECOF20:80		24.3	22.3	28.1
	PHB	19.9	22.1		

COMPARISON DIFFERENT TYPES OF FIBRE

20% fibers		30% fibers		
		La So.Le.	Rettenmaier	La So.Le.
YOUNG'S MODULUS (MPa)	PLA/ECOF50:50	2010	2805	3210
	PLA/ECOF20:80		676	
	PHB		4222	5028
ELONGATION AT BREAK (%)	PLA/ECOF50:50	11%	6%	4%
	PLA/ECOF20:80		19%	
	PHB		0.56%	0.8%
TENSILE STRENGTH (MPa)	PLA/ECOF50:50	32.87	42.7	38.8
	PLA/ECOF20:80		29.3	
	PHB		19.3	23.53

Poly(3-hydroxybutyrate)



Preventing the secondary crystallization



Improve the elongation

>4°C



Hard and brittle

Thin crystallites are formed in the amorphous region during storage at room temperature

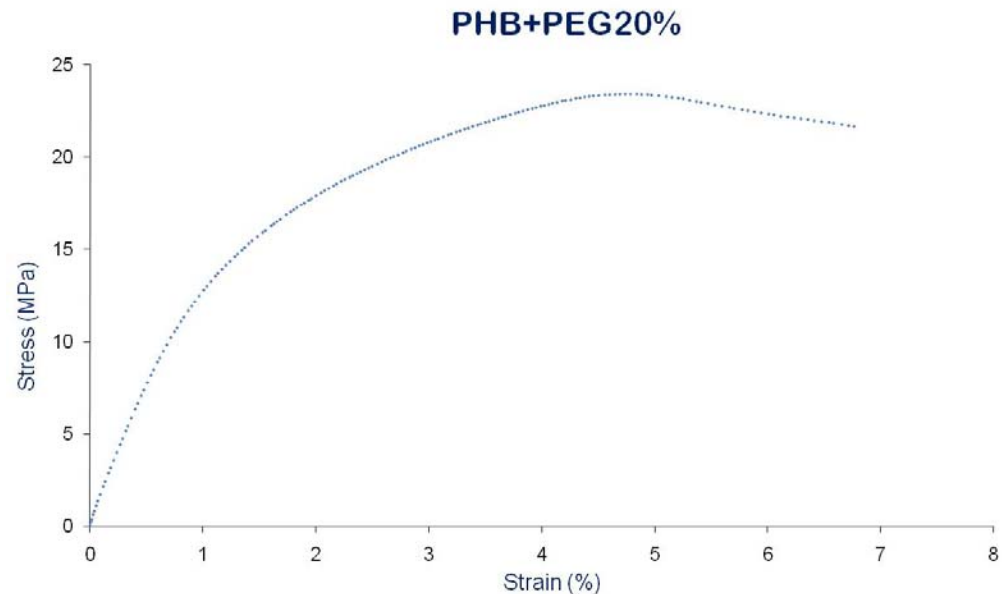

PHB

Elongation at break 0.87% → 2.3%

PHB+PEG(20%)

Elongation at break 7%

PHB+PEG(15%) + La So.le. 15%

Elongation at break 0.81% → 1.8%

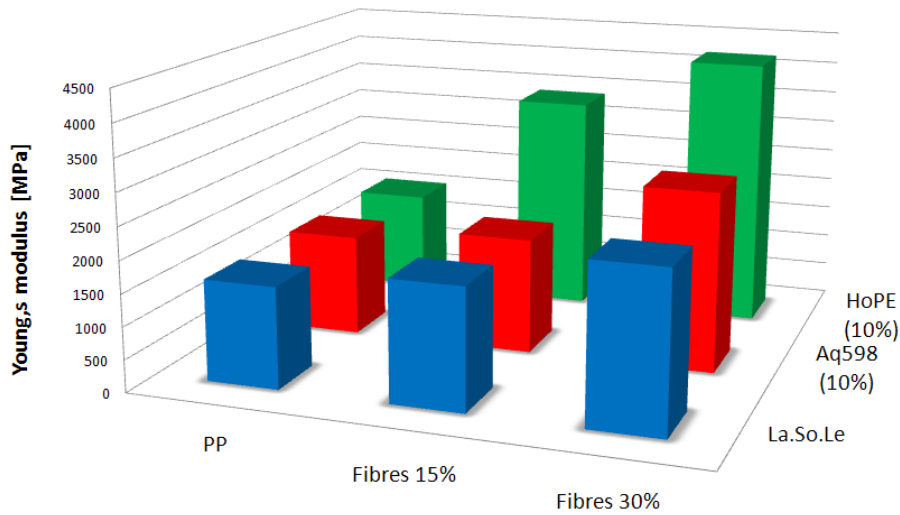

Young's modulus diagram of PP with wood fibres samples

	PP	Fibres 15%	Fibres 30%
La.So.Le	1570	1876	2436
Aq598 (10%)	1570	1797	2788
HoPE (10%)	1570	3383	4202

Young's modulus diagram of P226 with wood fibres samples

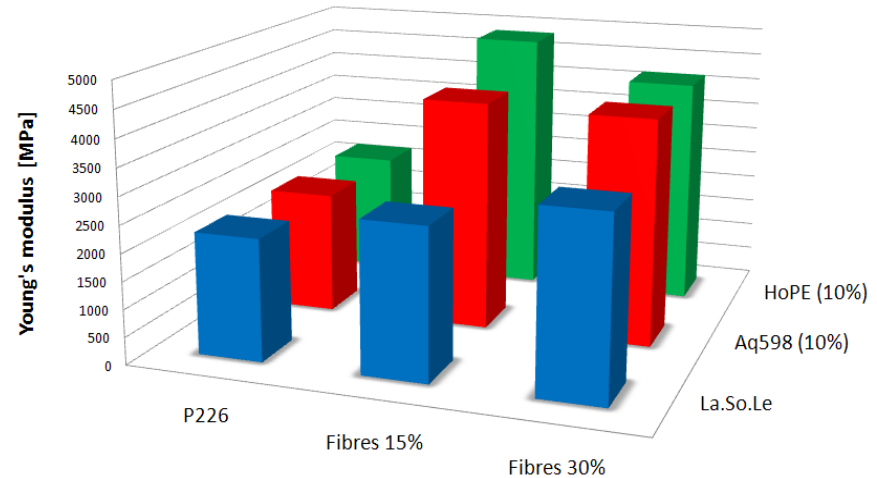

PHB226, and PP compounded with LS raw fibres and fibres treated with Aquacer 598 (Aq598), that is water based wax emulsion, and with Hordamer PE 02 that is an (HoPE) emulsion of polypropylene waxes

	P226	Fibres 15%	Fibres 30%
La.So.Le	2227	2753	3281
Aq598 (10%)	2227	4197	4137
HoPE (10%)	2227	4843	4177

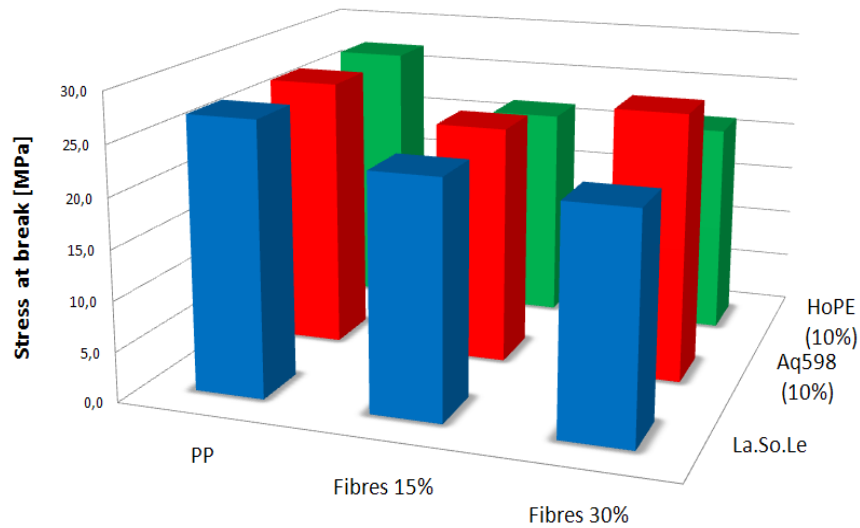

Stress at break diagram of PP with wood fibres samples

	PP	Fibres 15%	Fibres 30%
La.So.Le	27,2	23,3	22,1
Aq598 (10%)	27,2	23,9	26,7
HoPE (10%)	27,2	21,6	21,3

Stress at break diagram of P226 with wood fibres samples

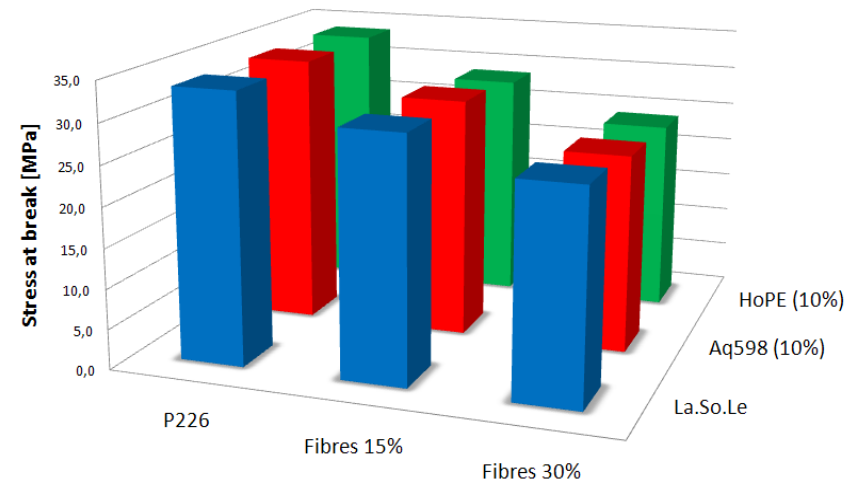

	P226	Fibres 15%	Fibres 30%
La.So.Le	33,6	30,2	26,1
Aq598 (10%)	33,6	29,9	24,7
HoPE (10%)	33,6	28,7	24,0

Elongation at break diagram of PP with wood fibres samples

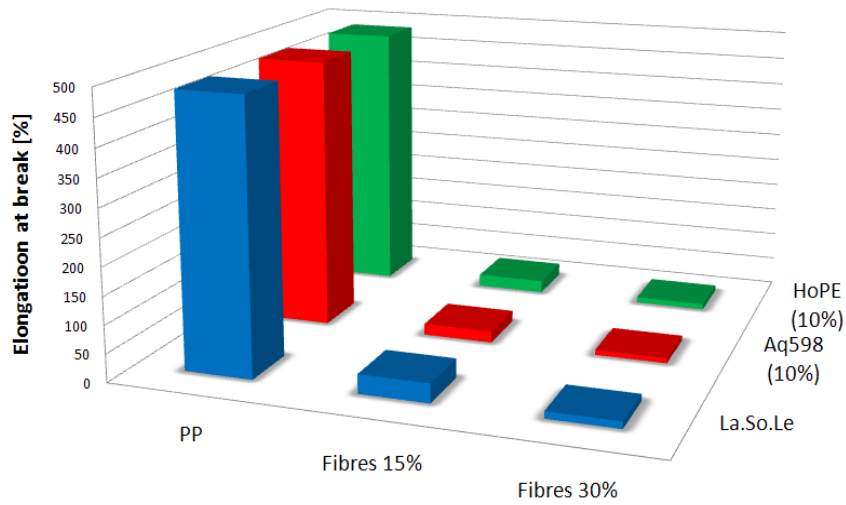

Elongation at break diagram of P226 with wood fibres samples

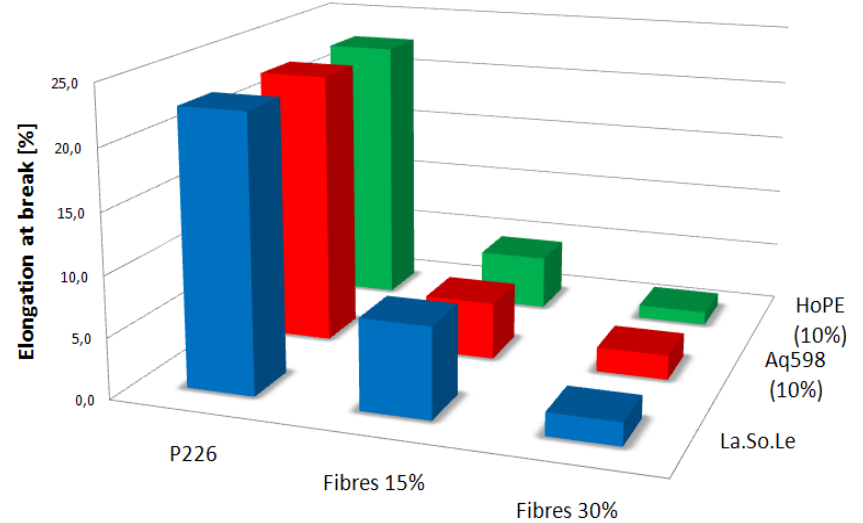

	P226	Fibres 15%	Fibres 30%
La.So.Le	22,7	7,5	1,9
Aq598 (10%)	22,7	4,8	2,0
HoPE (10%)	22,7	4,5	1,1

CONCLUSIONS

MECHANICAL REQUIREMENTS

Tomato yarn:

- Elongation > 15%



**PLA/ECOFLEX 20:80 +
RETTENMAIER wood
fibres (15-20%)**

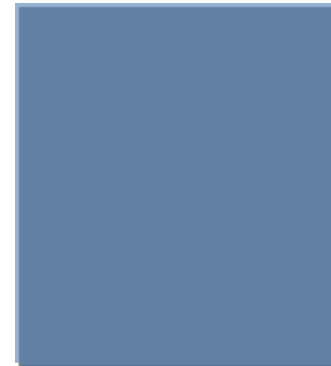

Packaging:

- Modulus 350-450 MPa
- Strength 53 MPa
- Elongation 2.4-10%



**PLA/ECOFLEX 50:50
+ RETTENMAIER
wood fibres (15-20%)
or La So.Le. wood
fibres (15-20-30%)**

University of Pisa Partner in:

A novel and efficient method for the production of polyhydroxyalkanoate polymer-based packaging from olive oil waste water



Collaborative Project

Small or medium-scale focussed research projects - Specific International Cooperation Actions (SICA) to promote the participation of emerging economies and developing countries: Latin America.

Work programme topics addressed: NMP.2011.2.3-1 Advanced packaging materials from renewable biogenic resources

Coordinated by IRIS, Innovacio i Recerca Industrial i Sostenible, Spain

University of Pisa Partner in:

DEVELOPMENT OF INJECTION AND BLOW EXTRUSION MOLDED BIODEGRADABLE AND MULTIFUNCTIONAL PACKAGES BY NANOTECHNOLOGY: IMPROVEMENT OF STRUCTURAL AND BARRIER PROPERTIES, SMART FEATURES AND SUSTAINABILITY

Collaborative Project

FP7 - NMP.2011.LARGE.5 Large-scale integrating collaborative projects

Work programme topics addressed: NMP.2011.1.1-1 Smart and multifunctional packaging concepts utilizing nanotechnology

Coordinated by AITIIP Foundation, Spain

WE INVITE YOU TO FORBIOPLAST WORKSHOP

**Bio-based Polymers and Composites of FORBIOPLAST
BIPOCO**



www.bipoco2012.hu

Siófok, Lake Balaton, Hungary
from 27-31.05.2012.

Hotel Azur

The conference is related to the
other FP7 projects Woody and
Biostruct.

