



**Arterris**  
L'Art de la Terre



# Coopérative ARTERRIS

Workshop Crops2Industry

*18<sup>th</sup> February 2011*

# A large Region Between the south west and the Mediterranean

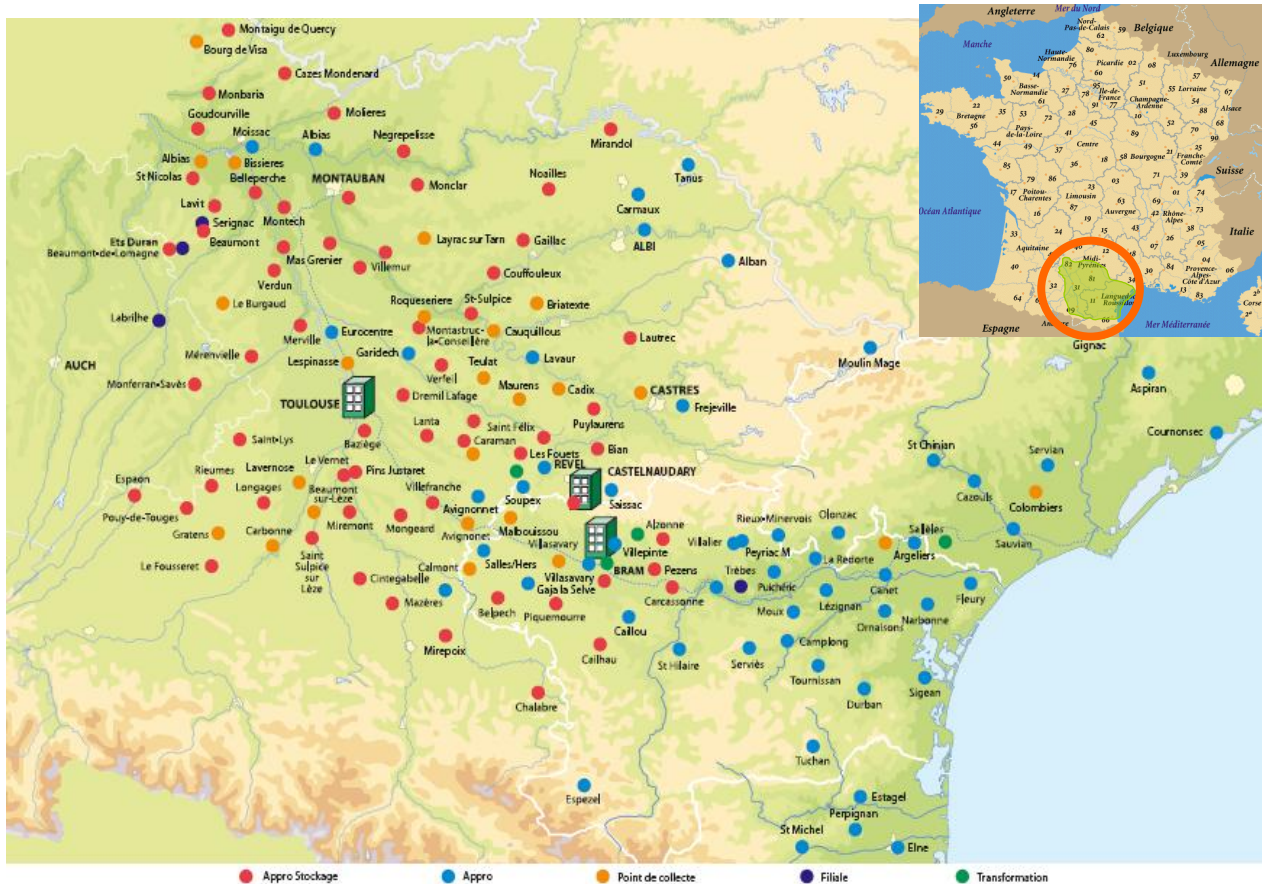

**FEWS NUMBERS**

- A turnover of 500 m€
- 1 100 employees
- 10 000 member formers
- 15 main subsidiary companies



# 6 basics

A varied cooperative

A varied territory and exploitations

A proximity to the Mediterranean region

Some proximity and varied fittings

Some strong positions about its activities  
( negotiation ability)

A financial stability that allows competitiveness,  
investments and innovation



# The Group's departments



## HARVEST

- Harvest and supply cereals : 357 M€ gross
- 753 000 tons harvested (corn, straw cereals, sunflower...)
- 220 000 hectares



## SUPPLY

- 185 M€ gross (manure, pesticides, seeds...)
- 33 000 m<sup>2</sup> : surface for retail stores of the chain "GAMM VERT"



## SEED SETTING

- 40 M€ gross (corn, cereals and oleaproteaginous...)
- 15 000 ha. of seeds (7 000 ha of hybrid seeds)



# The Group's departments



## ANIMAL FEED

- Animal feed and poultry : 121 M€ gross
- Cattle, sheeps, ducks, chickens, rabbits...
- 126 000 tons of animal feed



## POULTRY

- 5 500 000 animals produced (ducks, chickens, rabbits)



## FOOD INDUSTRY

- Flour : 126 000 tons
- Poultry for supermarkets and local markets : 4 200 000 animals
- Chickpeas : 900 tons
- White beans : 400 tons
- Lentils : 50 tons



# The sunflower crop production

- **Variety** : the choice should consider type of soil, yield, disease resistance and other constraints...
- **Planting** :
  - In soils have wormed to 8° C
  - From march to june or induding as a double crop
  - 65 000 to 70 000 plants by hectare (ha)

→ More we sow early more the yield increases
- **Fertily** : Sunflower has modest fertility needs, but
  - Nitrogen (N) is the most limiting factor for yield
  - Needs = N : 0 to 80 unity / year / ha
    - P and K = 0 to 60 unity / year / ha
    - Borom = 3 to 4 liter / ha



# The sunflower crop production

- **Weed control** :
  - Successful weed control should include a combination of cultural methods (crop rotation, work of soil, cover crops or stale seedbed technique) and chemicals methods
- **Diseases** : use resistant varieties
- **Harvest** : Seeds should be below 11 % moisture for good quality and long term storage



# The sunflower production

## Few numbers in 2010

	UE to 27		FRANCE		ARTERRIS	
	<i>Tons (t)</i>	<i>Area (ha)</i>	<i>Tons (t)</i>	<i>Area (ha)</i>	<i>Tons (t)</i>	<i>Area (ha)</i>
<b>Classic</b>	<b>3 780 000</b>	<b>2 000 000</b>	<b>895 200</b>	<b>373 000</b>	<b>34 000</b>	<b>16 200</b>
<b>Oleic</b>	<b>3 402 000</b>	<b>1 800 000</b>	<b>882 000</b>	<b>350 000</b>	<b>100 000</b>	<b>47 600</b>
<b>Very high oleic</b>	-	-	-	-	<b>500</b>	<b>250</b>

Oleic > 80 %

Very high oleic > 90 %

Yield : 2,2 to 2,8 tons per hectare



# Very high oleic sunflower

- **Crops** : very high oleic is identical to that the oleic sunflower
- **Harvest** : batch to be well isolated from the field in the stockage
  - The storage and the preservation are the same that for the classic or oleic sunflower
- **Analysis** : gas chromatography or by infrared soon
  - Low variability of the content in oleic acid between the field and the storage (0,1%)



# Interest of the very high oleic

- **New outlets** :
  - Edible oil
  - Meal
  - Industrial applications = biodetergents, biolubricants, hydraulic fluids
  - Lipo chemicals
- **Optimal development** :
  - Additional income for the farmer
  - Organization contractualized from the producer to the industrialist by way of the cooperative
  - Innovation throughout the agro-chain





# Ibiolab<sup>®</sup>



Improvement of **BI**olubricant Manufacturing and Development thanks to the  
Obtaining of Eco**LAB**els in a wide Range of Industrial Sectors

***Carine ALFOS***  
***Development Manager***

**[c.alfos@iterg.com](mailto:c.alfos@iterg.com)**



Internet Web Site

[www.ibiolab.com](http://www.ibiolab.com)

4 associations, 12 SMEs  
and 6 RTD  
In 7 European Countries



# Our Objectives was.....



**Biolubricants**

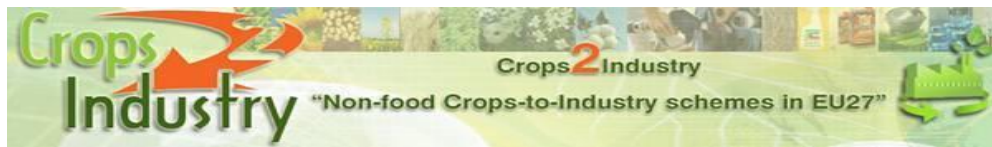
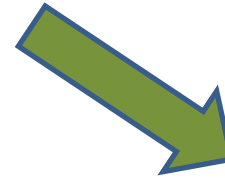
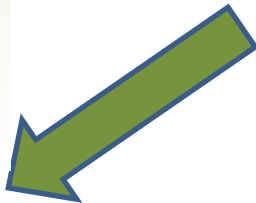

# FORMULATORS - GROUPS

PRODUCT	BAR	BSA	LUB	NAT	PAN	RSC	SOG	ZW
CHAIN SAW OIL		Leader	✓		✓			
DEMOULDING AGENT (Concrete)		✓	✓		✓		Leader	
DEMOULDING AGENT (Dye Casting)	✓							
HYDRAULIC FLUD	✓	✓		✓	Leader		✓	
GEAR OIL				Leader	✓			
2-STROKE OIL		✓			✓			
<b>LUBRICATING GREASES</b>		✓		✓		Leader	✓	
<b>MW FLUID (Neat oil)</b>			✓	✓	✓		✓	Leader
MW FLUID (Emulsion)	✓		Leader				✓	✓

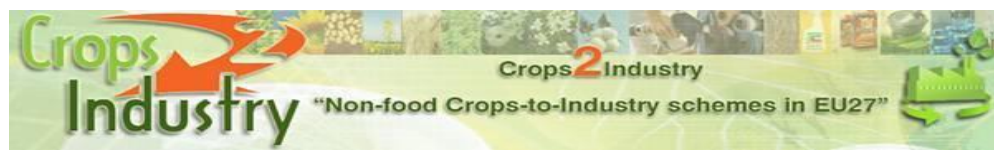



*Ibiolab*<sup>1</sup>



# Development of Biodegradable Greases for the UK Rail Industry

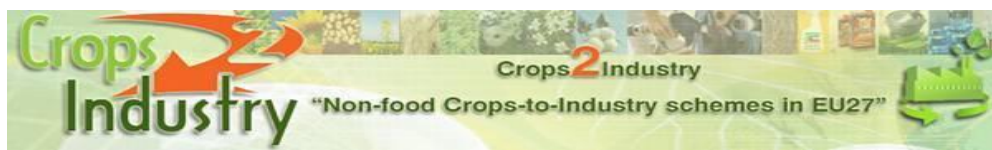

# Formulating a Grease

- ✓ Base Oil (65 – 95%)
- ✓ Thickener (soap) (5 – 35%)
- ✓ Additives (0 – 10%)



# IBIOLAB Project – Bio greases for UK Rail Industry

## Analytical Characteristics of the raw materials used

		UFO Solid Fraction	UFO Liquid Fraction	VHOSO SR3 Soft refined
Fatty Acid	Name	%	%	%
8:0	Caprylic acid	0.1	0.1	
10:0	Capric acid	0.1	0.1	
12:0	Lauric acid	0.2	0.3	
14:0	Myristic acid	2.2	1.6	
14:1	Myristoleic acid	0.4	0.4	
15:0		0.3	0.2	
<b>16:0</b>	<b>Palmitic acid</b>	<b>34.7</b>	<b>26.5</b>	<b>3.1</b>
16:1	Palmitoleic acid	1.6	1.9	
17:0	Margaric acid	<0.1	<0.1	
<b>18:0</b>	<b>Stearic acid</b>	<b>12.2</b>	<b>8.4</b>	<b>2.0</b>
<b>18:1</b>	<b>Oleic acid</b>	<b>35.2</b>	<b>43.2</b>	<b>88.3</b>
<b>18:2</b>	<b>Linoleic acid</b>	<b>11.0</b>	<b>14.8</b>	<b>4.5</b>
18:3 $\alpha$	Linolenic acid	0.5	0.6	0.2
20:0	Arachidic acid	0.3	0.3	
22:0	Behenic acid	0.3	0.3	0.7

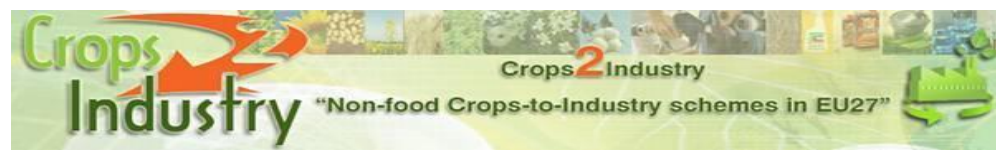

# IBIOLAB Project – Bio greases for UK Rail Industry

## Soft refining of crude VHOSO

- ✎ No centrifuge step – no waste water (Bleaching earths)
- ✎ No dewaxing step – no effect on Pour Point
- ✎ Reduced deodorisation temperature, 200°C → 160°C – Less Energy
- ✎ Less Steps = Lower Cost
- ✎ Less Refining = High content of naturally occurring Tocopherols (700ppm) = Increased Oxidation Stability

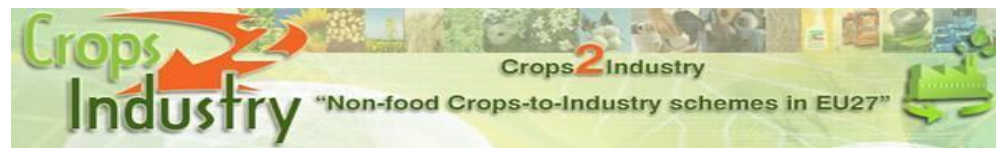

# IBIOLAB Project – Bio greases for UK Rail Industry

Summary of Test Results for XP4a (12HSA in VHOSO SR3)	
Worked Penetration (IP50)	310 – 340
Mechanical Stability (100,000 strokes)	+16 points
Drop Point (IP396)	174.2°C
Water Washout (IP215)	2.2%
Oil Separation (IP121) - 18 hours	1.35%
Oil Separation (IP121) - 1 week	4.48%
Oxidation Stability (IP142)	-0.8 Bar (-11.2psi)
4-Ball (IP239)      Weld Load	280kg
Scar Diameter	0.60mm

# IBIOLAB Project – Bio greases for UK Rail Industry

## Test OECD 201, “Alga growth inhibition test”

Additive	EL <sub>50</sub>	Classification
IBIOLAB XP4a	>100mg/l	“Not toxic / not harmful to aquatic organisms”.

## Test OECD 202 “Daphnia Magna” The 24h EC50 Acute Immobilisation

Additive	EL <sub>50</sub>	Classification
IBIOLAB XP4a	>1000mg/l	“Not toxic / not harmful to aquatic organisms”.

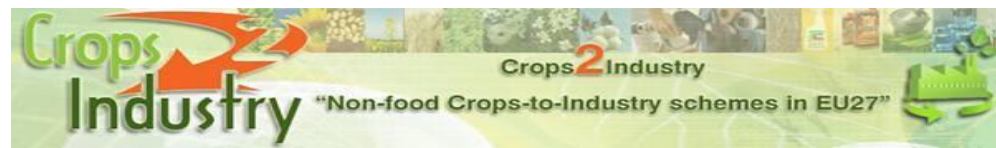

# IBIOLAB Project – Bio greases for UK Rail Industry

## OECD 301F Manometric Respirometry Test

### % Biodegradation

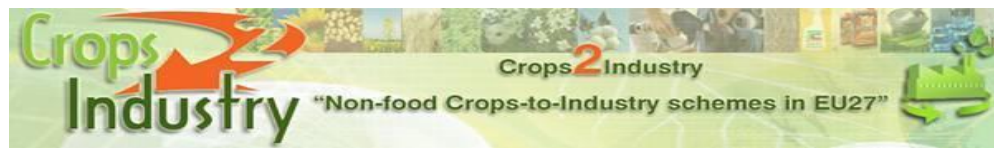
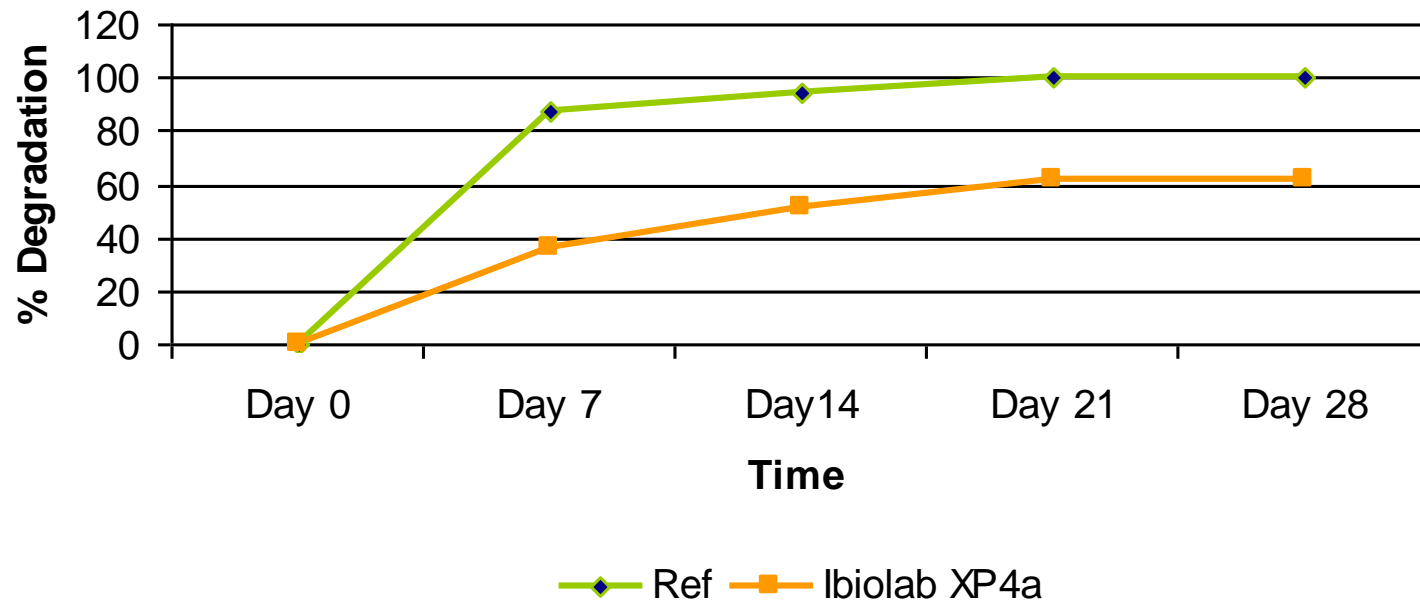

# IBIOLAB Project – Bio greases for UK Rail Industry

OECD 301F Manometric Respirometry Test

Result > 60%

Classified as ‘Ultimately biodegradable’

☞ **Test results suggest XP4a will qualify for the European Ecolabel**

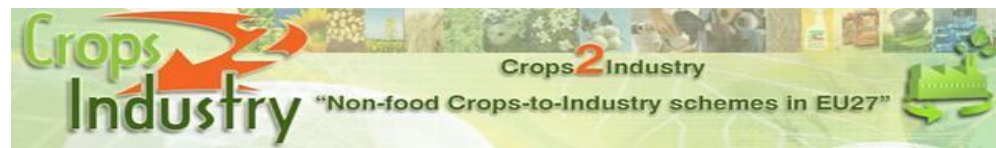

# IBIOLAB Project – Bio greases for UK Rail Industry

## Cost Summary

XP4a	Classical 12HSA soap in VHOSO SR3 base fluid	€1177.22/tonne
XP6a	UFO solid fraction soap in VHOSO SR3 base fluid	€1166.45/tonne
XP11a	UFO solid fraction soap in UFO base fluid	€878.96/tonne
Mineral oil product	Classical 12HSA soap	€971.32/tonne

# IBIOLAB Project – Bio greases for UK Rail Industry

## Sheffield Supertram – trial started 23/04/09

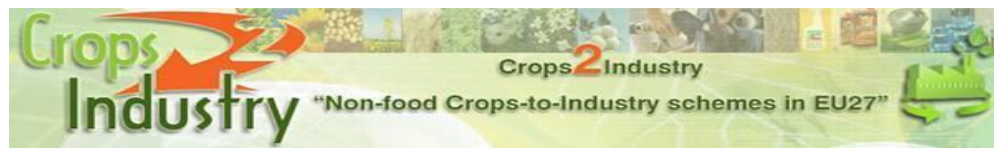

# IBIOLAB Project – Bio greases for UK Rail Industry



# IBIOLAB Project – Bio greases for UK Rail Industry

Setting up the trial.....



# IBIOLAB Project – Bio greases for UK Rail Industry



# IBIOLAB Project – Bio greases for UK Rail Industry

Mineral oil based product



Biodegradable product



# MOTULTECH Know How



METALWORKING

PROTECTION



METAL  
DEFORMATION

HEAT  
TREATMENT



DEGREASERS

STONE AND  
MINERALS



HIGH PERFORMANCE  
LUBRICATION

LUBRICATION



Development of a new product answering to  
the **most severe requirement in terms of HSE**

## Criteria of European Ecolabel

% renewable resources

Ecotoxicity, Bioaccumulation

Biodegradability

Performances

No hazards labelling



What is machining?

Conventional machining: material removal method

Different metalworking processes (milling, turning, drilling...) with a sharp cutting tool to mechanically cut the material in order to achieve the desired geometry

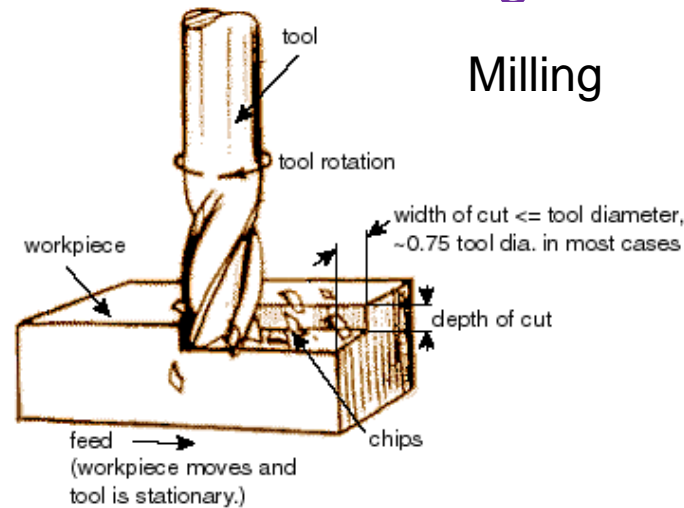

# Machining basics

It is necessary to understand well the machining operation in order to provide the right lubricant.

The objective of cutting oil is to stop temperature's increase by acting on two parameters :

➤ Evacuation of heat

➔ cooling the tool

➔ **cooling effect**

➤ Reduction of heat generation

➔ decreasing frictions between part and tool

➔ **lubricating effect**



# Bioneat oil : Specification

**Bioneat oil** ⇒ Multipurpose neat oil with low viscosity

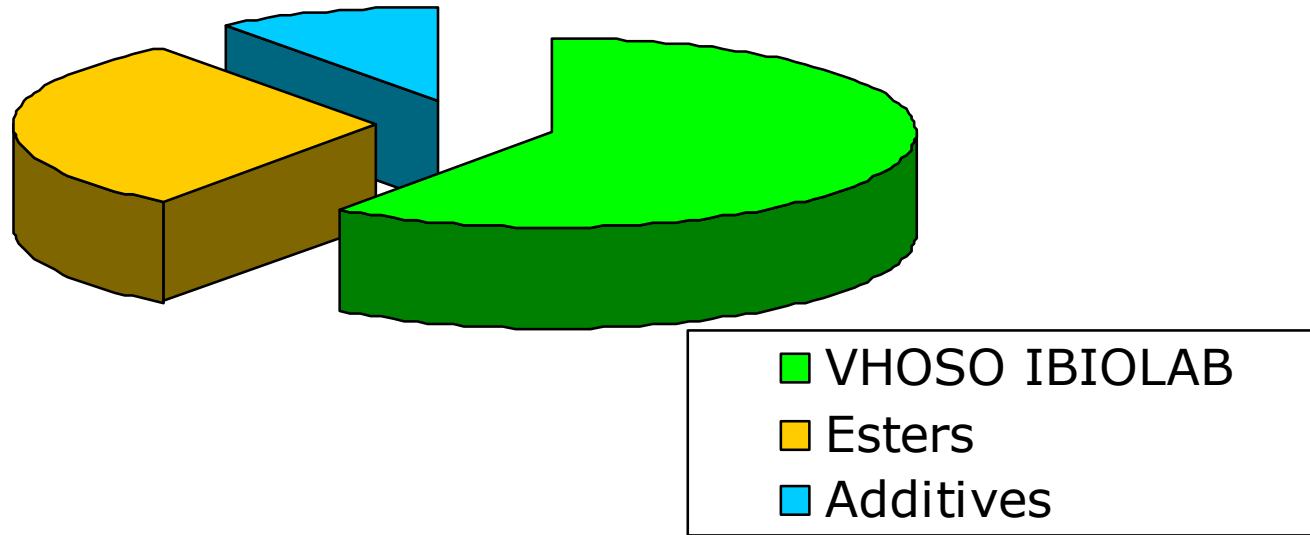

Additives and esters specially chosen thanks to our experience in terms of biolubricant.

# Performance results

Cooling capacity **BIONEAT OIL**

Viscosity@ 40°C : 22mm<sup>2</sup>/s

➔ Fire risk

Flash point (*ASTM D 92*): the higher the better

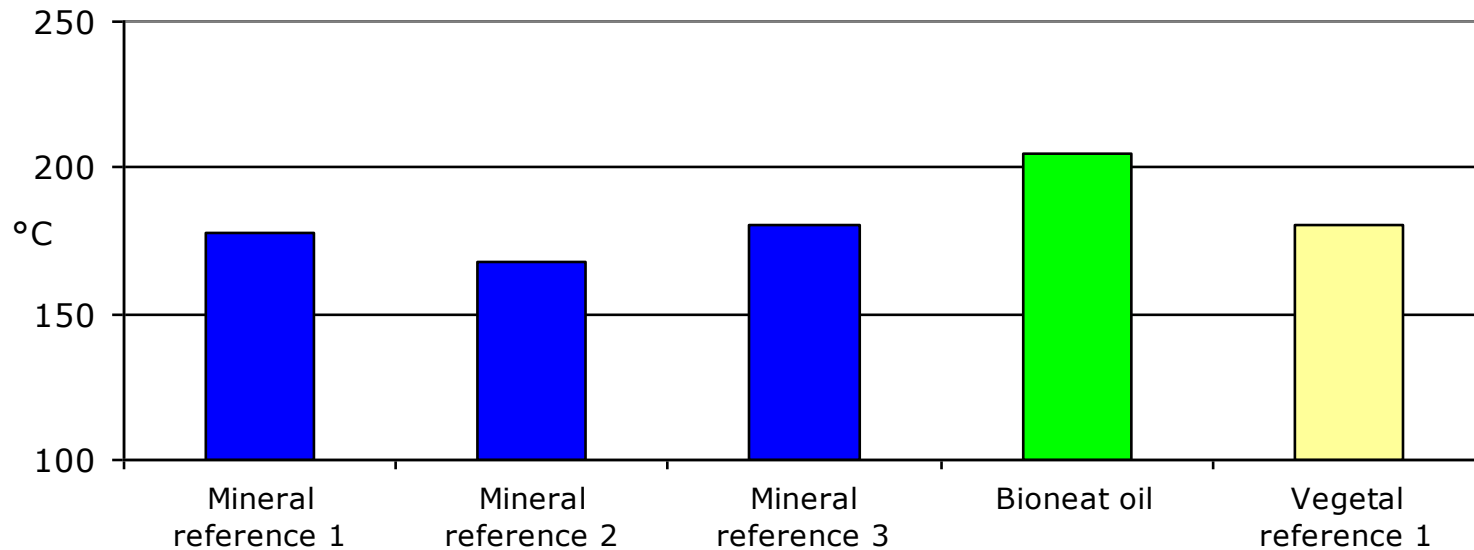

**Excellent result in terms of flash point**

↳ **Lowers fire risk**

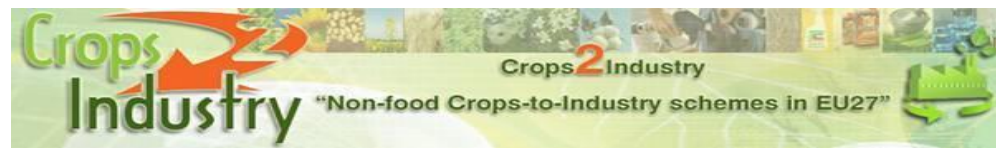

# Performance results

## Lubricating capacity **BIONEAT OIL**

Wear scar *4balls test\_ASTM D 2783* : the lower the better

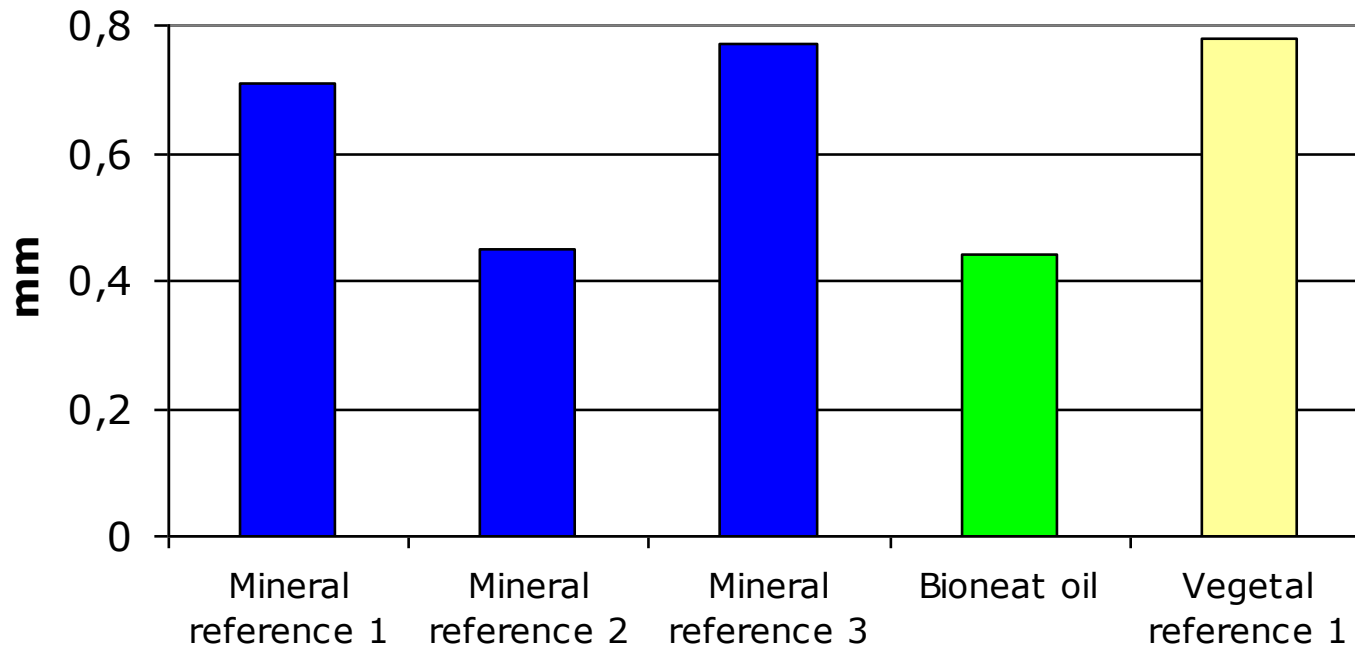

Excellent result in terms of lubricating properties.

↳ Mainly linked to the polarity of the VHOSO base oil.

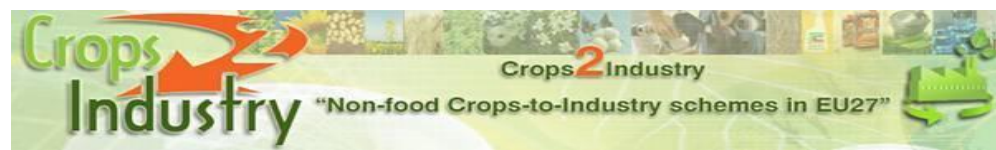

# Performance results

## Lubricating capacity **BIONEAT OIL**

Weld load *4balls test ASTM D 2783* : the higher the better

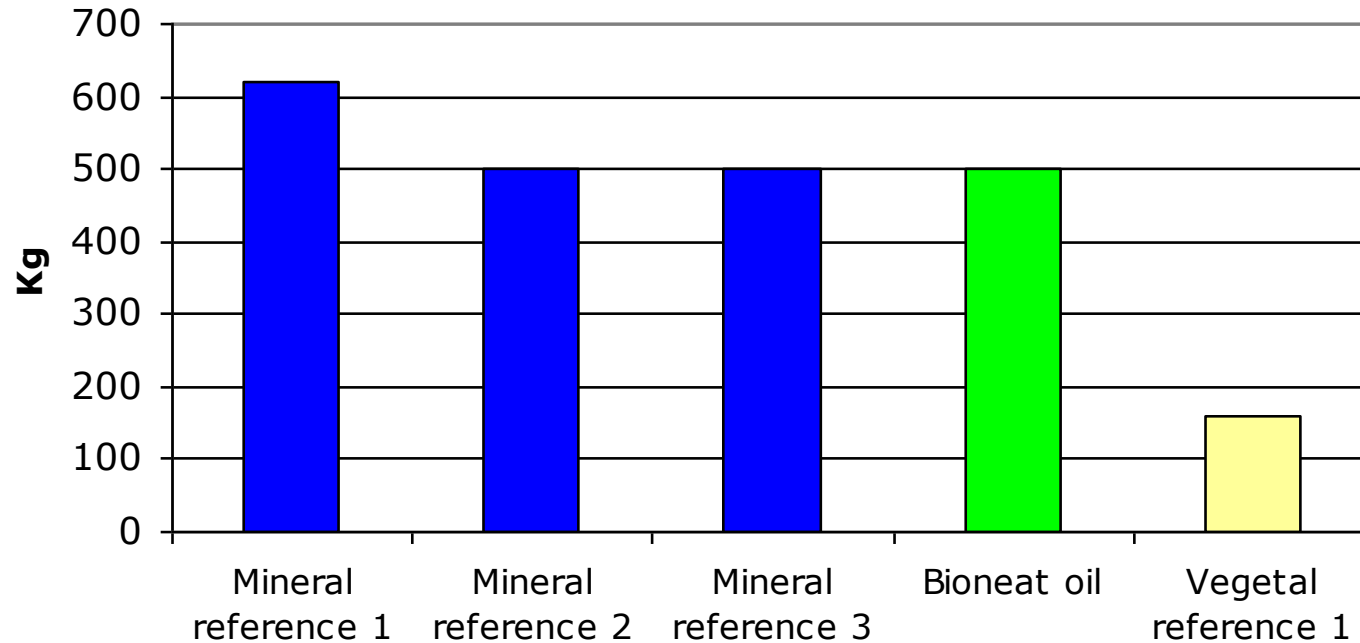

The weld load achieved with Bioneat oil is a very good results and is highly better than vegetal ref 1.



# Performance results

## Anti mist properties **BIONEAT OIL**

Mist *CNOMO D 65 1649* : the lower the better

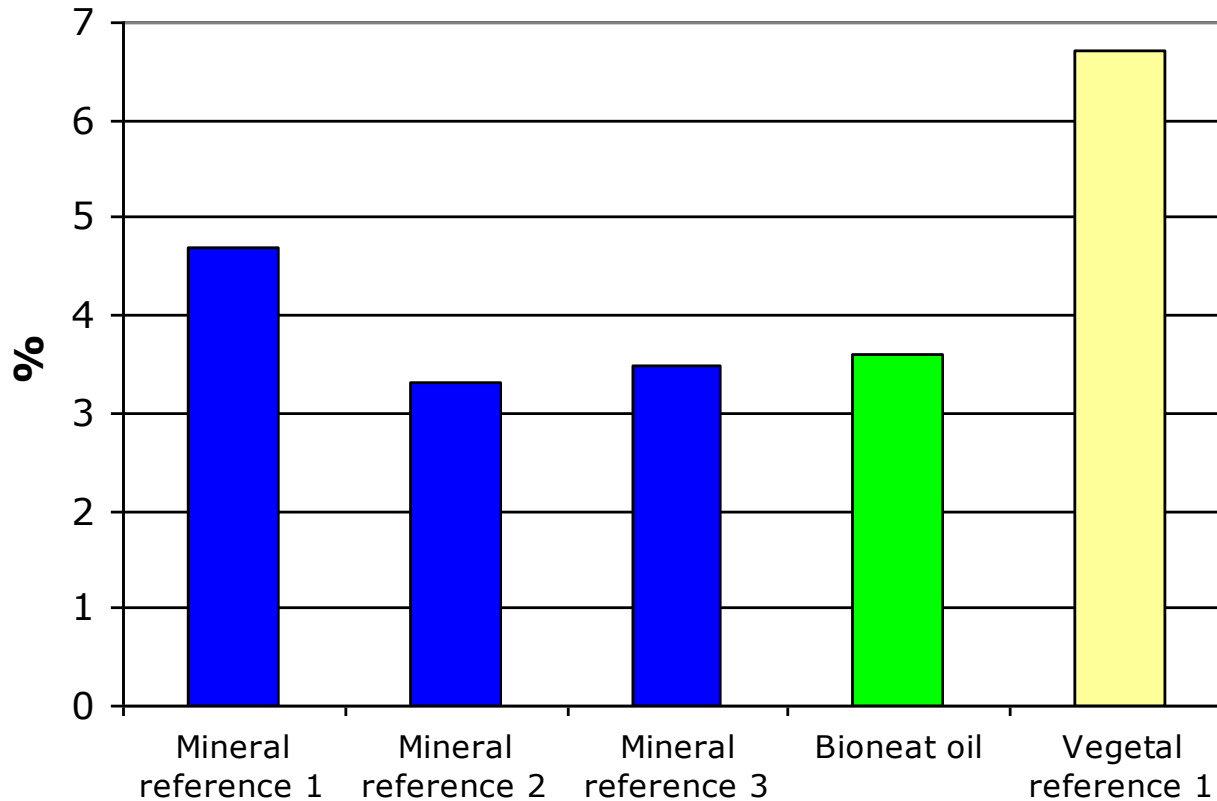

Anti-mist properties of Bioneat oil shows similar results to mineral oil base product



# Performance results

## Gumming properties **BIONEAT OIL**

Gumming *CNOMO D65-1663*: the lower the better

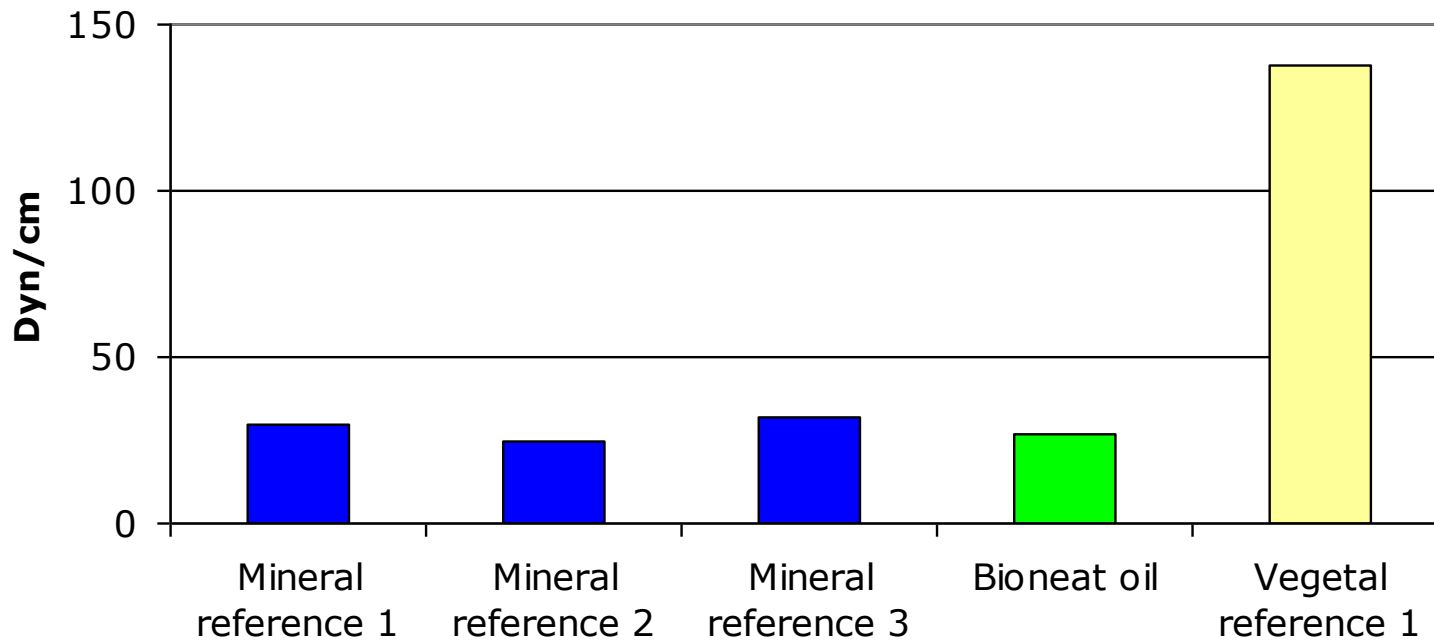

No Gumming effect has been observed  
on Bioneat oil

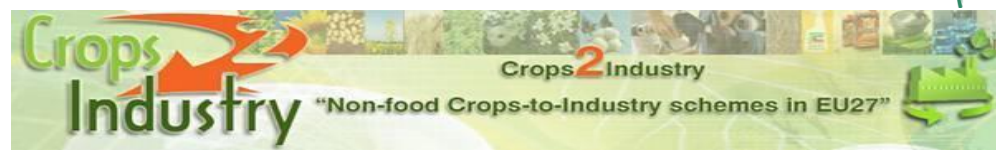

# Performance results

## Oxidation stability **BIONEAT OIL**

Oxidation stability *ASTM D 2272* : the higher the better

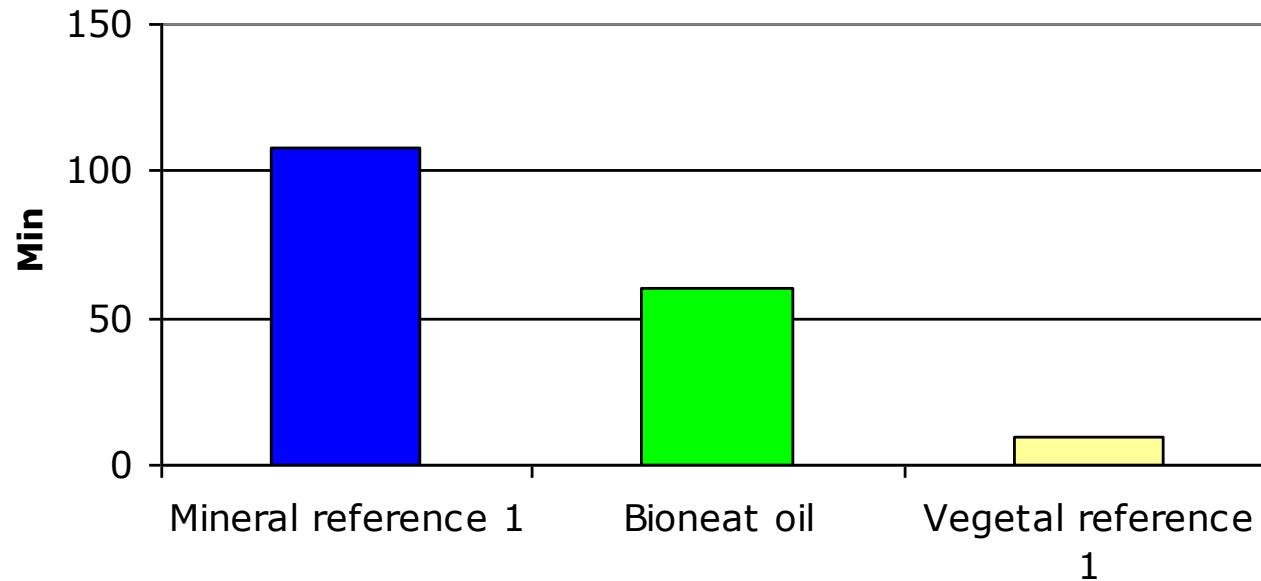

Improvement of oxidation stability

To be tested on field



## Bioneat oil

### Ecotoxicity

□ **Algae** (OECD 201) : EC50 -72h > 100mg/l

↳ Not toxic  ✓

□ **Daphnis** (OECD 202) : EL50 -48h > 1000mg/l

↳ Not toxic  ✓

□ **Fish** (OECD 203) : EL50 -48h > 1000mg/l

↳ Not toxic  ✓

# Ecotoxicity results

## Bioneat oil

% of renewable resources >90%



No hazards labelling



Ultimate Biodegradability (OECD 301 B) > 60%



# Conclusion

In terms of machining performance **Bioneat oil** shows very good results and can compete with mineral based formulation.



Oxidation stability has to be checked on field

**Next step:** Industrial testing

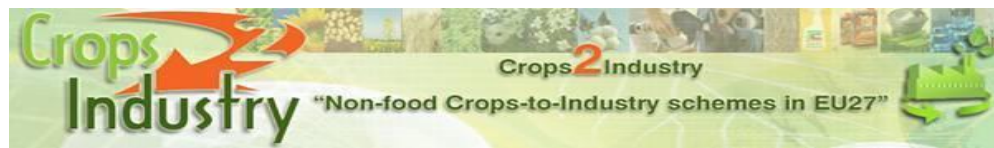

# And The following.....

## New European Project : VOSOLUB

- 👉 Testing the IBIOLAB HOSO bio-lubricants **in three demonstrating sites in three European Member States**
- 👉 States: hydraulic fluids in Spain, greases in the UK, and cutting oil in France.
- 👉 Evaluating and comparing the technical performance and environmental impacts of the new formulations and the mineral lubricants ones.
- 👉 Fostering the transfer of the VOSOLUB results at the European scale through a dissemination plan relying on an information campaign promoting the use of bio-lubricants.
- 👉 **Creating an active European SMEs network** specialized in bio-lubricants production ensuring the supply of VOSO raw material at a competitive market price.

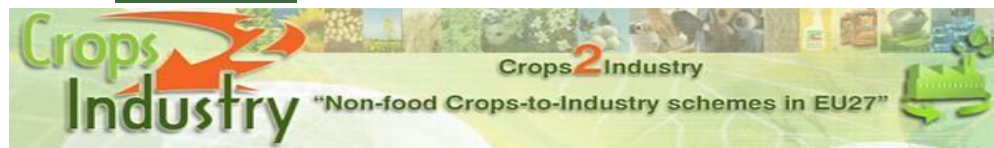

*c.alfos@iterg.com*



Thank you for your attention



[www.iterg.com](http://www.iterg.com)

[www.cedop.iterg.com](http://www.cedop.iterg.com)

