



KAPÉ
CRES

Designing Open Spaces in the Urban Environment: a Bioclimatic Approach



RUROS

Rediscovering the **U**rban
Realm and **O**pen **S**paces



Fifth Framework Programme 1998 – 2002
Co-financed by the European Union

Key Action 4 "City of Tomorrow and Cultural Heritage"
from the programme
"Energy, Environment and Sustainable Development"



Authors

Introduction	1
1. Thermal Comfort Models for Open Urban Spaces	2
<i>Dr Marialena Nikolopoulou, Spyros Lykoudis and Maria Kikira</i> <i>Centre for Renewable Energy Sources, Department of Buildings, Greece</i>	
2. Considerations of the Wind in Urban Spaces	7
<i>Niels-Ulrik Kofoed and Maria Gaardsted</i> <i>Esbensen Consulting Engineers Ltd., Denmark</i>	
3. Evaluation of Radiant Conditions in Urban Spaces	12
<i>Prof. Gianni Scudo, Dr Valentina Dessi and Prof. Alessandro Rogora</i> <i>B.E.S.T. Building Environmental Science and Technology Department, Milan Polytechnic, Italy</i>	
4. Urban Morphology	17
<i>Dr Koen A. Steemers, Marylis C. Ramos and Maro Sinou</i> <i>The Martin Centre for Architectural and Urban Studies, Department of Architecture,</i> <i>University of Cambridge, UK</i>	
5. Thermal Comfort Mapping and Zoning	22
<i>PD Dr Lutz Katzschner, Ulrike Bosch and Mathias Roettgen</i> <i>Faculty of Urban and Landscape Planning, Department of Climatology, University of Kassel, Germany</i>	
6. Visual Comfort in Urban Spaces	27
<i>Dr Raphaël Compagnon and Joëlle Goyette-Pernot</i> <i>Haute Ecole Spécialisée de Suisse Occidentale: Ecole d'ingénieurs et d'architectes de Fribourg, Switzerland</i>	
7. Sound Environment and Acoustic Comfort in Urban Spaces	32
<i>Prof. Jian Kang, Wei Yang and Dr. Mei Zhang</i> <i>School of Architecture, University of Sheffield, UK</i>	
8. Design Principles and Applications	37
<i>Prof. Niobe Chrisomallidou, Prof. Max Chrisomallidis and Dr. Theodore Theodosiou</i> <i>Laboratory of Building Construction and Building Physics, Faculty of Civil Engineering,</i> <i>Aristotle University of Thessaloniki, Greece</i>	
9. Social Considerations at the Design of Open Spaces	42
<i>Kallisteri Avdelidi</i> <i>National Centre for Social Research, Greece</i>	
10. Evaluation of Tools	47
<i>Dr Marialena Nikolopoulou with contribution from the authors of the respective chapters</i>	
11. Glossary	51

LEGAL NOTICE

Concerning the information contained in this publication, the authors are solely responsible for it. The views given in this publication do not necessarily represent the views of the European Commission. Neither the European Commission, nor any person acting on behalf of the Commission, is responsible for the use, which might be made of the information contained in this publication.

INTRODUCTION

There is strong public interest in the quality of open urban spaces and it is acknowledged that they can contribute to the quality of life within cities, or contrarily enhance isolation and social exclusion. This relates to the physical and social environment, the underlying hypothesis being that these conditions affect people's behaviour and usage of outdoor spaces.

The current Guide examines the design of open spaces through bioclimatic principles, as evaluated in the context of project RUROS. A common platform has been developed for the analysis of open spaces in the urban environment, combining the physical environment (i.e. microclimate, thermal, visual and audible comfort, urban morphology, etc.) with user requirements and satisfaction.

Various models and tools of different complexity have been developed, tackling different issues of the physical environment and the resulting environmental performance. These provide insight on the different aspects of the environment, and means for analysis at different levels of complexity, for a range of users from beginner to expert. The range of tools developed, include the following.

- Simplified models to predict thermal comfort conditions, using publicly available meteorological data, along with information on thermal sensation and adaptation characteristics.
- A methodology to evaluate the velocity profile of an area with simplified design recommendations for the effect of a neighbourhood on the wind conditions of an open space.
- A graphic tool to evaluate the thermal comfort conditions of a design scheme, giving a variation of the radiant thermal load as a function of the use of different materials.
- A methodology for evaluating the environmental impact of alternative urban forms, examining the environmental performance of urban textures, contributing to temperature, sun and wind analysis.
- A methodology for drawing comfort maps, concentrating on the spatial analysis of thermal comfort zones.
- Relationships between measurable parameters and users' sensations for the luminous environment, along with a methodology to assess cumulative sunlight penetration in a given space through multistereographic projections.
- A methodology for describing the soundscape in urban open spaces, comprising of characteristics of each sound source, acoustic effect of the space, social and other aspects, along with simplified models for sound propagation in urban squares.
- A methodology to connect the social issues experienced in contemporary urban life with the physical properties characterising an open space. The issues and indicators, which have arisen, link together the overall social function of urban open spaces and the descriptive analysis of selected open spaces with the design procedure.

RUROS has provided a unique set of extensive field surveys carried out across Europe, including extensive microclimatic monitoring and modelling of open spaces, along with questionnaire guided interviews with users of open spaces. Two open spaces of different typology have been investigated at each of the seven cities across Europe (Athens [GR], Thessaloniki [GR], Milan [IT], Fribourg [CH], Cambridge [UK], Sheffield [UK], Kassel [D]). Overall the data set consists of over 10,000 records with interview and environmental data, which formed the basis for the various models presented in the current publication.



These models and tools are to be employed by architects, planners or other urban designers, at the early design stage, in order to evaluate the environmental impact of different design proposals. Some of the tools, e.g. thermal comfort models, acoustic models, effect of materials and analysis of the radiant environment can be employed directly by a designer through the description and different steps provided in the respective chapters. Other tools, such as the analysis of the urban texture and the effect on the microclimate, or mapping of the thermal environment require different software for their application, in cases where detailed information is desirable.

In order to demonstrate how this new knowledge can be employed, an evaluation of the various tools and methodologies is presented for a design proposal in Thessaloniki, for a future pedestrian street. The physical environment of the area is identified and analysed for its environmental performance, along with the social parameters and characteristics of the different population groups in the area.

Overall, the current Guide provides a significant step into identifying important parameters that need to be taken into consideration at the design stage of open spaces, for interventions in the urban fabric or even new developments within the urban context. The proposed approach will assist the design of cities through the design of outdoor spaces and eventually the use of these spaces, by allowing for different activities to be carried out and social interaction to take place, giving life back to the cities' open spaces. Ultimately, this systematic knowledge can contribute to the sustainable development of cities of the future.

1. THERMAL COMFORT MODELS FOR OPEN URBAN SPACES



Figure 1.1: Different use of space at different microclimatic conditions, top -summer daytime, bottom - summer evening.

1.1 Introduction

One of the primary objectives of environmental design in the urban context is the creation of urban blocks with comfortable open spaces. Microclimatic parameters are therefore of central importance for the activities that are carried out in the area and to a great extent, determine their use. Responses to the microclimate may be unconscious, but they often result in a different use of open space in different climatic conditions (Fig. 1.1) [1]. Thus, understanding the richness of microclimatic characteristics in outdoor urban spaces, and the comfort implications for the people using them, opens up new possibilities for the development of urban spaces.

The environmental parameters affecting thermal comfort conditions outdoors, even though similar to indoors, are encountered within a much wider range and are more variable. Therefore due to this complexity, in terms of variability, temporal and spatial, as well as the great range of activities people are engaged in, there have been very few attempts to understand comfort conditions outside.

1.2 Adaptation

In most outdoors thermal comfort studies, a purely physiological model has been used involving a mathematical model of the thermoregulatory system employed for calculating thermal satisfaction, dependent upon environmental conditions, the activity of people and their clothing level. Field surveys, however, have revealed that a purely physiological approach is inadequate to characterise thermal comfort conditions outdoors, whereas the issue of adaptation becomes increasingly important. This involves all the processes which people go through to improve the fit between the environment and their requirements, both at a physical and psychological level. In the outdoor context, it involves personal changes [2], with the seasonal variation of clothing, changes in the metabolic heat with consumption of cool drinks, as well as changes in posture and position, whereas psychologically [3], personal choice, memory and expectations prove to be a critical parameter for satisfaction with the thermal environment.

1.3 Thermal Sensation

In the context of the current project, outdoor thermal comfort conditions have been evaluated through field surveys in 14 case study sites across Europe. People's thermal sensation has been evaluated on a 5-point scale, varying from "very cold" to "very hot", and has been defined as the Actual Sensation Vote (ASV). Analysing the data that has been collected revealed correlations between microclimatic parameters and ASV.

Figure 1.2 presents the variation of ASV in relation to air temperature and wind speed. Examining mean values of ASV, there is evident correlation between the two variables. As expected, with respect to wind speed there is a weak negative correlation with ASV, indicating that ASV reduces as wind speed increases. The relatively weak correlations between microclimatic variables and ASV indicate that one parameter alone is not sufficient for the assessment of thermal comfort conditions.

The subjective data collected from the interviews was compared with the thermal index Predicted Mean Vote (PMV) [4], developed originally for the indoor environment and gradually employed for the outdoor context as well. PMV is calculated by taking into account the mean

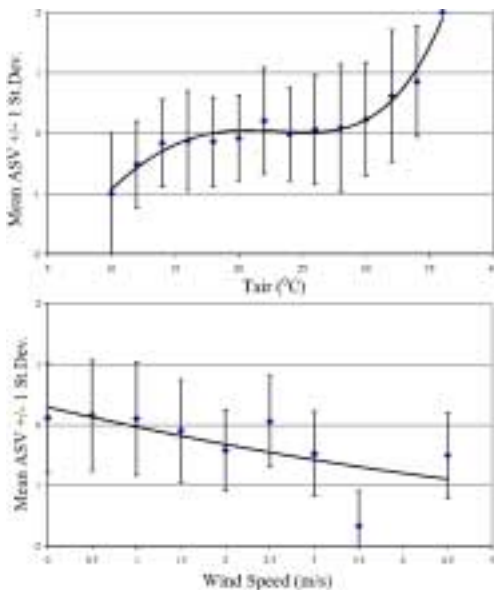

Figure 1.2: Distribution of the Mean Actual Sensation Vote of the interviewees (ASV), with the respective deviation in relation to Air Temperature (top) and Wind Speed (bottom), for the surveys in Athens.

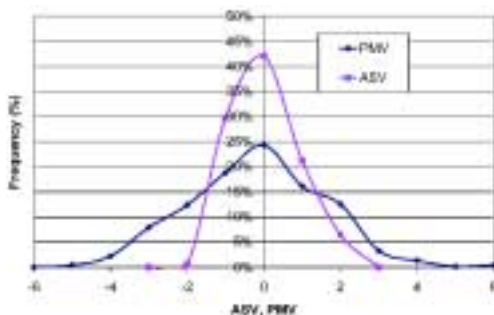

Figure 1.3: Comparison of the Actual Sensation Votes (ASV) obtained from the questionnaires with the Predicted Mean Votes (PMV) for Athens, calculated from the mathematical model, for each interviewee.

objective environmental parameters recorded for the duration of the interview, clothing levels and metabolic rate, for each interviewee. Comparing the PMV for each interviewee with the corresponding ASV, revealed a great discrepancy between the two, as actual thermal comfort appears to be found at higher levels than implied by the mathematical model (Fig. 1.3).

The wide range of microclimatic conditions in outdoor spaces strengthens the point that a purely physiological approach is inadequate to characterise thermal comfort conditions outdoors, whereas the issue of adaptation becomes increasingly important. Personal changes, with the seasonal variation of clothing (Fig. 1.4), changes in the metabolic heat with consumption of cool drinks [2], changes in posture and position (Fig. 1.5), whereas psychologically [3], personal choice, memory and expectations (Fig. 1.6) prove to be important parameters.

The consistent discrepancy between actual and theoretical comfort conditions outdoors gave us ground to investigate and develop models for the thermal comfort conditions outdoors, based on the empirical data gathered from the field surveys with nearly 10,000 interviews across Europe, rather than on existing theoretical models.

1.4 Thermal comfort models

From the design point of view, it is useful to develop simple models that can predict thermal comfort conditions, using readily available data. Simple linear models have been developed using publicly available meteorological data, from a nearby station. These models are important for the prediction of ASV in an adequate way, since they can be the platform on which outdoor thermal comfort nomograms and maps can be constructed. It should be borne in mind that personal parameters that people bring into the open spaces and the effect of adaptation, physically and psychologically, are intrinsic in the models presented below.

1.4.1 City comfort index

Models for the calculation of ASV are presented for the different cities, corresponding to different climatic zones, based on hourly meteorological data. The parameters used are air temperature (T_{air_met} , °C), global solar radiation (Sol_met , $W.m^{-2}$), wind speed (V_met , $m.s^{-1}$) and relative humidity (RH_met , %):

- Athens (GR):
 $ASV = 0.034 T_{air_met} + 0.0001 Sol_met - 0.086 V_met - 0.001 RH_met - 0.412$ (r = 0.27)
- Thessaloniki (GR):
 $ASV = 0.036 T_{air_met} + 0.0013 Sol_met - 0.038 V_met + 0.011 RH_met - 2.197$ (r = 0.51)
- Milan (IT):
 $ASV = 0.049 T_{air_met} - 0.0002 Sol_met + 0.006 V_met + 0.002 RH_met - 0.920$ (r = 0.44)
- Fribourg (CH):
 $ASV = 0.068 T_{air_met} + 0.0006 Sol_met - 0.107 V_met - 0.002 RH_met - 0.69$ (r = 0.68)
- Kassel (D):
 $ASV = 0.043 T_{air_met} + 0.0005 Sol_met - 0.077 V_met + 0.001 RH_met - 0.876$ (r = 0.48)
- Cambridge (UK):
 $ASV = 0.113 T_{air_met} + 0.0001 Sol_met - 0.05 V_met - 0.003 RH_met - 1.74$ (r = 0.57)
- Sheffield (UK):
 $ASV = 0.07 T_{air_met} + 0.0012 Sol_met - 0.057 V_met - 0.003 RH_met - 0.855$ (r = 0.58)

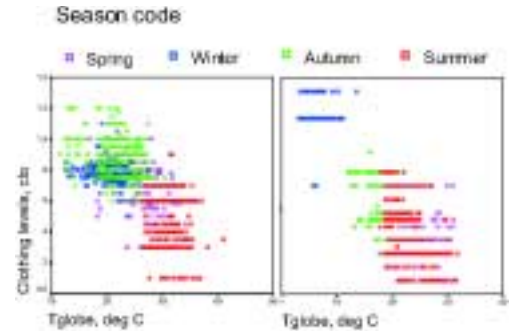

Figure 1.4: Seasonal variation of clothing (clo) with globe temperature (°C), Athens (left) and Kassel (right).

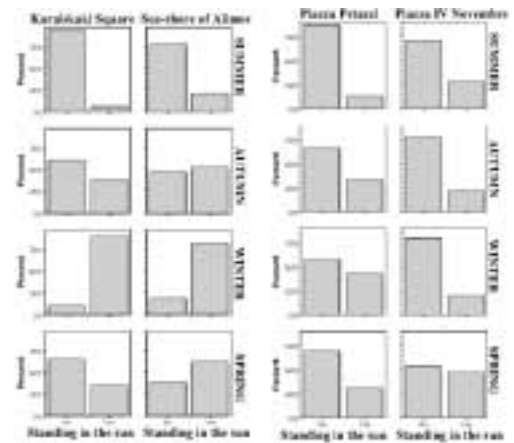

Figure 1.5: Seasonal variation of people standing in sun and shade, at the different sites in Athens (left) and Milan (right).

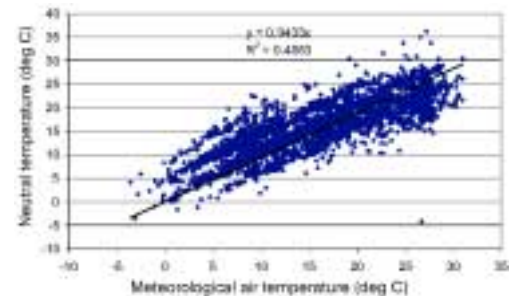

Figure 1.6: Thermal Neutrality, i.e. where people feel neither warm nor cool, lying close to Meteorological Air Temperature (°C), from all surveys across Europe, is an indication of the influence of people's recent experience.

Table 1.1. Meteorological conditions for nomograms

Air temperature (°C)	Solar radiation ($W.m^{-2}$)	Relative Humidity (%)	Wind Speed ($m.s^{-1}$)
0	100	20	0.1
5	400	40	1.0
10	800	80	3.0
15			5.0
20			
25			
30			
35			
40			

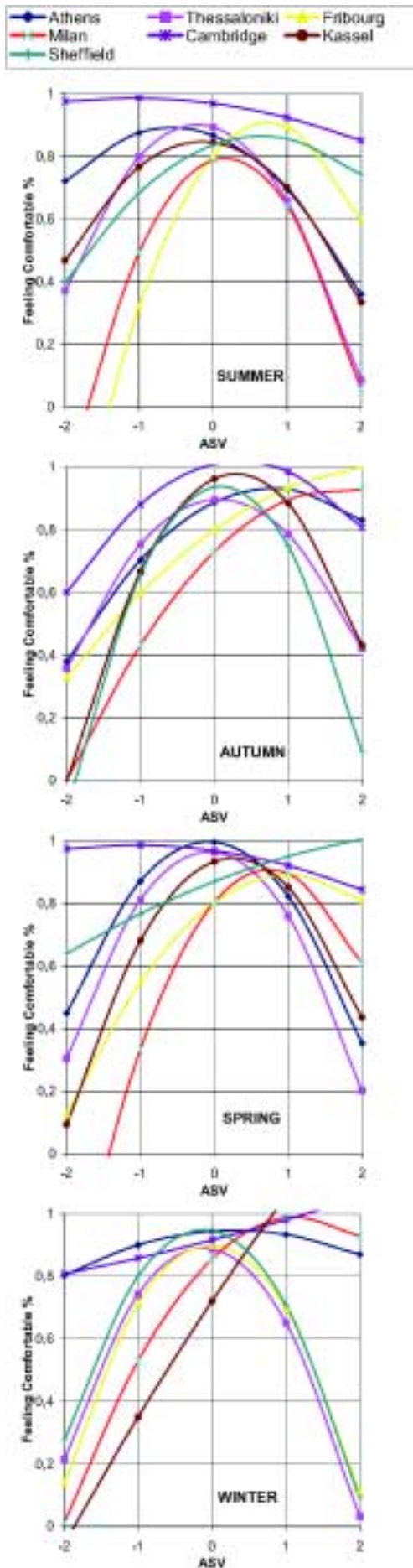

Figure 1.7: Ratio of people feeling comfortable for different ASVs, for the different cities, at different seasons.

These models, which indicate the most significant contributions from T_{air_met} and V_{met} , can be used to obtain a Comfort Index for a city for different seasons. Combining the initial and the seasonally aggregated data from each site, a combined model was developed, when it became apparent that ASV levels could not be interpreted uniformly, in terms of comfort/discomfort, either on a city or a seasonal basis. Thus one model was required for ASV and another to obtain the comfort/discomfort ratio for a city (Fig. 1.7).

From Figure 1.7, it is apparent that very cold conditions are more tolerable during summer and spring compared to the other two seasons for all cities. Very hot conditions are thought as comfortable mainly in autumn and spring.

1.4.2 Comfort nomograms

In architectural application it is useful to provide the designer with models in the form of graphs. Such graphs (nomograms) giving a mean ASV have been plotted, according to a combined model for Europe, presented below. A selected range of meteorological parameters have been used, typical for different climatic zones in the cities examined in Europe.

- Combined model for Europe:

$$ASV = 0.049 T_{air_met} + 0.001 Sol_met - 0.051 V_{met} + 0.014 RH_met - 2.079 \quad (r = 0.78)$$

Solar radiation values of 100, 400 and 800W.m⁻² correspond to low insolation (e.g. overcast or late sunny afternoon), average insolation (e.g. partly cloudy or winter clear day) and high insolation (e.g. summer clear sky conditions) respectively. Relative humidity values of 20%, 40% and 80% correspond to very dry, average and humid conditions. Finally, the wind speeds of 0.1, 1, 3 and 5m.s⁻¹ correspond to stale conditions, slight breeze, and strong wind, since above 5m.s⁻¹ the mechanical effects of wind are more important than the thermal effects (Section 2.1).

For specific values of the meteorological parameters, the designer can refer to the respective models (either the European or the city-specific ones) and calculate the corresponding ASV values. It should be pointed out, that the lack of interviews with ASV under very hot and very cold leads to centrally biased results and there is no statistically sound remedy for that. For this reason the designer is advised to limit the use of the model and respective nomograms for meteorological air temperature in the range of 5 to 35°C. Due to the ambiguity regarding the interpretation of mean ASV in terms of comfort/discomfort, the results can then be combined with the city specific curves to obtain the percentage of people feeling comfortable from this mean ASV.

Thus the urban designer is prompted to calculate or estimate the ASV value corresponding to the climatic conditions of the area of interest, using either the model's equation or the nomograms presented in Figure 1.8, and then enter this value to the curves of Figure 1.7 to obtain the percentage of users that would feel comfortable. Then using microclimatic modification factors associated to certain design options, the task can be repeated, to investigate how design options would affect the percentage of comfortable users.

1.4.3 Comfort index for microscale

In the case of areas with a great variety of spaces, ranging from dense vegetation and extensive shading, to areas completely exposed to the sun and wind, the data from the meteorological station cannot adequately represent the microclimatic conditions in the site. Comfort models should be able to approach the microscale for design purposes, distinguishing between sunny and shaded areas, or areas protected and exposed to the wind, which ultimately directly affects thermal comfort conditions in a given space. It is therefore of value to devise a way to include design related parameters into environmental data.

Identifying simplified correction factors between locally measured conditions and those of the nearby meteorological station, during the field surveys, can reflect the modification of the microclimate. Such correction factors can be used as modification parameters for design oriented comfort models, reflecting the microscale, thus of value to designers.

In this context, vegetation can affect the microclimate in a number of ways, reducing air temperature compared to hard surfaces, shading and providing wind protection. With reference to the models presented in Section 1.4.1, it is possible to include such effects for evaluation. In the urban context [5], a reduction of the surrounding air temperature by 1-2°C is expected, with a dense group of trees (Fig. 1.9), whereas the incoming solar radiation can be reduced to 20-60% according to the density of the trees. Such figures can be expected in the summer, for clear sky conditions, whereas no correction factor should be used in case of overcast conditions. With respect to the wind, a permeability factor of 0.4 can be employed for evaluating the reduction of wind speed due to vegetation, which can be reduced to 0.2 in case of vegetation used as wind-breaks.

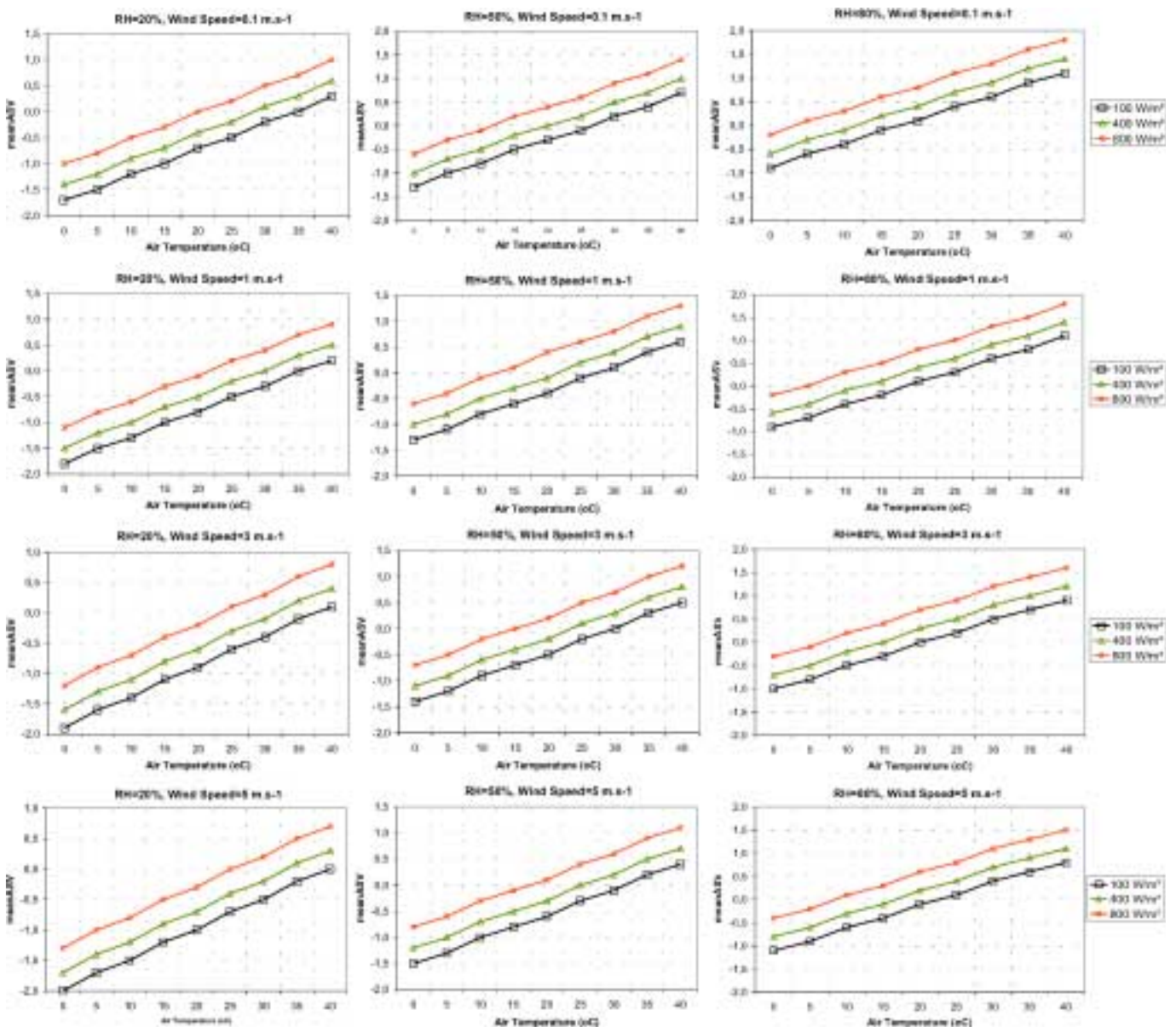

Figure 1.8: Nomograms for meanASV for different meteorological parameters.



Figure 1.9: Variation of microclimate due to vegetation.

E.g, in the case of Athens, in the summer, at noon (typically $T_{air}=33^{\circ}\text{C}$, $Sol_{met}=1000\text{W.m}^{-2}$, $V_{met}=1\text{m.s}^{-1}$, $RH_{met}=30\%$), the effect of a dense group of trees on ASV can be calculated, employing the model presented in Section 1.4.1:

$$ASV = 0.034 (T_{air_met}-2) + 0.0001(0.2 \times Sol_{met}) - 0.086 (0.4 \times V_{met}) - 0.001 RH_{met} - 0.412.$$

$$ASV=0.034 \times (33-2) + 0.0001 \times (0.2 \times 1000) - 0.086(0.4 \times 1) - 0.001 \times 30 - 0.412 = 0.6, \text{ presenting a 14\% reduction to the value without shading.}$$

1.5 Checklist

The following steps can be followed:

- Determine geographic location and obtain meteorological climatic data
- Identify city with the greatest climatic similarity to city under consideration, or use the European model.
- Calculate ASV for the corresponding city, or read value from respective nomogram, taking into account approximate values.
- Read percentage of people feeling comfortable from curves.
- Include design parameters with correction factors to calculate ASV for the different spaces, checking different design options.
- Read percentage of people feeling comfortable from curves.
- Repeat previous steps, as required.

1.6 Conclusions

The above methodology can be employed at the early design stage to identify potential problem areas, evaluating different generic strategies, e.g. shading, wind protection, etc. They are not precision models to justify designer actions and have to be combined with the rest of the work presented in this Guide, for the role of materials (Section 3), etc.

At the design of open spaces, contact with nature is one of the primary objectives for the use of open spaces, and has to be encouraged through design. Environmental stimulation is an important reason for the use of open spaces for different activities, throughout the year, and careful design can contribute to it, with environmental conscious differentiation, as daily and seasonal variations require different solutions (Section 4.3.6).

The urban designer has different choices for the design solutions; building morphology, materials, vegetation, water elements, even urban equipment can contribute to the successful design of urban spaces, by providing protection from negative and exposure to positive aspects of the climate, increasing the use of outdoor space throughout the year.

1.7 References

- [1] Nikolopoulou, M., Baker, N. and Steemers, K. (2001). Thermal comfort in outdoor urban spaces: the human parameter, *Solar Energy*, Vol. 70, No. 3.
- [2] ISO 7730 (1994). *Moderate thermal environments - determination of the PMV and PPD indices and specification of the conditions for thermal comfort*, International Standards Organization, Geneva.
- [3] Nikolopoulou, M., Baker, N. and Steemers, K. (1999). Thermal comfort in urban spaces: different forms of adaptation, *Proc. REBUILD 1999: The Cities of Tomorrow*, Barcelona.
- [4] Nikolopoulou, M. and Steemers, K. (2003). Thermal comfort and psychological adaptation as a guide for designing urban spaces, *Energy and Buildings*, Vol. 35, No.1.
- [5] Dimoudi, A. and Nikolopoulou, M. (2003). Vegetation in the urban environment: microclimatic analysis and benefits, *Energy and Buildings*, Vol. 35, No.1.

2. CONSIDERATIONS OF THE WIND IN URBAN SPACES

2.1 Wind Environment

One of the most important factors influencing pedestrian comfort conditions in outdoor open spaces is the wind. Wind environment is difficult to foresee and control because it is influenced by a number of global, regional and local factors. On a global scale wind comes from air moving from high-pressure areas to low-pressure areas. The wind velocity and direction produced by the global weather systems are subsequently influenced by the regional and local landscape typology. It is therefore important to understand that there can be large differences in the wind environment from one part of a city to another or even on micro scale from one part of a space to another.

Wind is not a constant phenomenon – it varies momentarily in direction and strength (wind gusts) and variations can be seasonal or annual. Wind velocities in this guideline therefore always refer to average values.

The direct effects of the wind can be divided into two main categories - mechanical and thermal effects [1]. Mechanical effects of wind can be felt with wind velocities above 4-5m.s⁻¹. Above 10m.s⁻¹ it will be unpleasant to walk and above 15m.s⁻¹ there is a direct risk of accidents [2]. For thermal effects the 5m.s⁻¹ comfort criteria in Table 2.1 can be used, if it is presumed that people will adapt their behaviour and clothing level to the season [3]. The table can be used for air temperatures above 10°C.

It should be noted that depending on climate a certain level of wind could be regarded as undesirable or desirable. In cold climates wind will almost always decrease outdoor comfort conditions, whereas the opposite is the case in hot climates.

2.2 Wind data

The free undisturbed wind high above the surface of the earth is called the geostrophical wind. The geostrophical height is varying from around 275 m to about 500 m depending on the roughness (α) of the surface of the earth (Fig. 2.1 and Table 2.2).

Local wind data are vital when assessing the wind environment in open spaces. The most important being the mean wind velocity and the wind direction during the period where the space is occupied. If a space is occupied during the whole year, data should be obtained for all seasons and for each month if there is notable difference between months in the same season. Wind data are usually measured 10m high above ground in meteorological stations situated in country site. Wind data can be found in a wind atlas – a record book with wind roses for several sights in a country, which often can be found at the national meteorological institute. A wind rose is a graphical overview of the local wind velocities and directions for a specific site based upon measurements over a longer period of time (Fig. 2.2).

A wind velocity measured at the meteorological station 10m high in flat open country can be transferred to a wind velocity in urban area for a given height (H) using Table 2.3. H is the height above ground in the urban area and S is the relationship between the wind velocity in the urban area at height H (V_H) and the wind velocity in open flat country in 10 m height (V_{10}). Thus $S = V_H / V_{10}$.

Table 2.1.

Characteristics of the 5 m/s criteria.

A= Acceptable, U= Uncomfortable,

VU= Very uncomfortable/ Dangerous [3].

Activity	Area	Characteristics		
		A	U	VU
Rapid walking	Pavements, paths	43%	50%	53%
Strolling	Parks, shopping streets	23%	34%	53%
Standing/sitting for a short period	Parks, urban spaces	6%	15%	53%
Standing/sitting for a long period	Outdoor restaurants	0.1%	3%	53%

E.g. The wind environment will be acceptable for people sitting for shorter periods in open spaces, if a mean wind speed of 5 m.s⁻¹ is not exceeded for more than 6% of the time. If people are sitting for longer periods 5 m.s⁻¹ should not be exceeded for more than 0.1% of the time.

Table 2.2.

Geostrophical height and terrain roughness

α for three types of terrain [1,2]

Terrain	Height (m)	α
Flat open land	275	0.16
Woodland, suburban	400	0.28
Heavily built-up urban areas	500	0.4

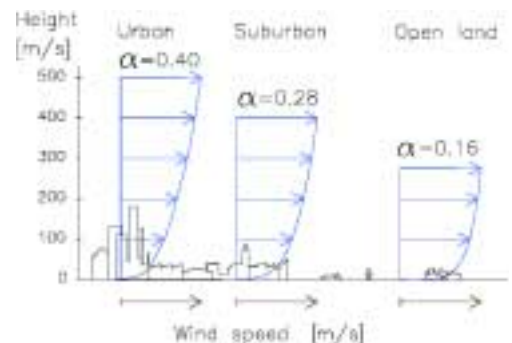

Figure 2.1: Wind velocity profile for three different types of terrain. The roughness α is highest at a dense city with large buildings.

Table 2.3.
Values of $S = V_H / V_{10}$ for various heights H
for suburban and urban area.

H [m]	S(suburban)	S(urban)
10	0.6	0.36
20	0.73	0.47
30	0.82	0.55
40	0.89	0.62
50	0.94	0.68
60	0.99	0.73
70	1.04	0.77
80	1.08	0.82
90	1.11	0.86
100	1.14	0.89
110	1.18	0.93
120	1.21	0.96
130	1.24	0.99
140	1.27	1.02
150	1.29	1.05

E.g. Wind speed at 100m high in an urban area corresponds to 89% of the wind velocity at 10m height in flat open country.

It should be noted that the data in Table 2.3 are valid only for heights above the urban area (above the roofs) and not where local obstacles such as buildings are dominating the wind environment. Thus Table 2.3 can be used to calculate the wind conditions above roof height in the area where the open space are situated and not to calculate the wind conditions in the pedestrian zone in the space.

V_H or V_{10} can be transferred to a wind speed and direction in the pedestrian zone using wind tunnel test or advanced CFD calculations. An alternative is to use diagrams showing simple relationships between either V_H or V_{10} and the wind speed in the pedestrian zone [e.g. 1, 2, 6], which have been derived from advanced measurements or calculations. However, it should be noted that it not advisable to transfer results from a generic study or from a specific case to another space in a real design situation. The complexity of the wind flow in the pedestrian zone in urban areas is very high and even small changes in the layout of the space or the neighbourhood can dramatically change the wind pattern on the space. Thus each space has to be analysed as an individual case.

2.3 Full scale tests, wind tunnel tests or advanced simulations

There are different possibilities when evaluating the wind distribution in an open space. It is possible to either take measurements (full scale on site or wind tunnel) or to use a computer model to simulate the airflow.

Full scale measurements have the advantage that the results obtained are from the real situation, where the influence from all buildings and obstructions is included. The drawback is that it can be quite costly as ideally the measuring period should be long enough to cover the most frequent combinations of wind velocity and direction, thus it will be necessary to have a high number of measurement points. It is also difficult to test new design solutions.

Wind tunnel tests have the advantage that reliable results for a high number of combinations of wind velocities and directions can be obtained quite fast. It is also possible to test the wind environment in new areas when still in the planning phase and to test new design solutions. However, it is vital to use an experienced wind laboratory and to build up a precise model of the concerned area and the surroundings. Thus wind tunnel tests can be time consuming and costly.

An alternative to wind tunnel tests is to build up a computer model of the space and the surrounding area, to simulate airflow – a kind of virtual wind tunnel. Programs of this type of simulations are called Computational Fluid Dynamics (CFD) and the advantage is that any combination of wind velocity, direction and physical layout of the space and its surroundings can be assessed. However, the calculations require a lot of computer power and it is vital for the user to be very experienced in using the software and to understand complicated air flow problems.

2.4 Example of an analysis of wind conditions with CFD

The objectives of the example study are to assess the effect of different parameters on wind conditions at pedestrian level (1.5m above ground), in a quadrangle space surrounded by buildings. The topography of the surrounding neighbourhood is included in the CFD model in order to take into account the effect of the surrounding urban structures (Fig. 2.3). The height of the neighbourhood is modelled as 18m ($H_{\text{Neighbourhood}}$).

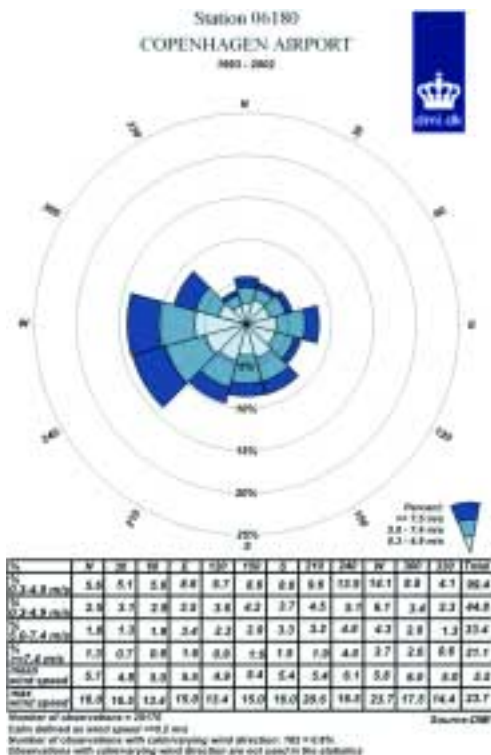

Figure 2.2: Wind rose incl. data table, Copenhagen airport (DK), All year (1993-2002). E.g. the wind around 4% of the year comes from west with a wind velocity above 7.5 m.s⁻¹ (source: Danish Meteorological Institute).

The study involves the following parameters:

1. Size of the square (A_{Square}): 1600m² and 3600m².
2. Wind velocity in open land at 10m height (V_{10}): 2.5m.s⁻¹ and 5m.s⁻¹.
3. Height of the boundary buildings (H_{Boundary}): 9 m, 18 m, 27 m.
4. Wind direction: 0°, 15°, 30°, 45° (Fig. 2.3).
5. Width and location of the four openings to the square (Figs. 2.4–2.5).

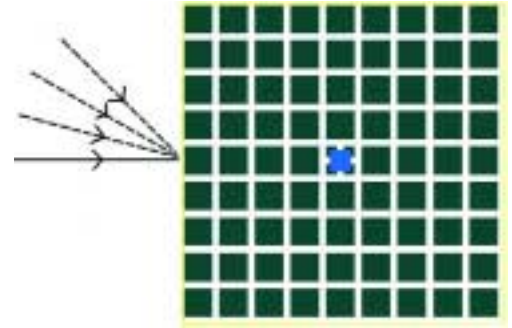

Figure 2.3: Graphical presentation of the CFD model with wind directions (0°, 15°, 30°, 45°). The square is located in the middle of the model surrounded by the suburban neighbourhood modelled as rectangular blocks of 18m height.

2.4.1 Observations and conclusions from the study

Observations:

- The bigger the square – the higher the wind speed in the space, with an almost linear relationship between A_{Square} and wind speed.
- The bigger the square – the more turbulent is the wind flow.
- The higher the wind velocity V_{10} – the higher is the wind speed in the square, with an almost linear relationship between V_{10} and wind speed.
- The flow pattern and level of turbulence is almost unaffected by V_{10} .
- The higher the boundary buildings compared to the neighbourhood – the higher is the wind speed on the square (Fig. 2.6).
- The higher the boundary buildings compared to the neighbourhood – the higher is the wind turbulence (Fig. 2.7).
- There is no clear relationship between the overall wind direction and the wind speed in the square (Fig. 2.6).
- The higher the inlet angle of the wind – the higher is the wind turbulence. There is a clear tendency that the flow pattern becomes more chaotic the more the overall wind direction varies from the main orientation of the space.
- There is no clear relationship between the wind speed on the square and the location of the openings to the space.
- Openings in the corners of the square give a more turbulent flow pattern than openings in the middle of the square (Fig. 2.8).
- The bigger the openings – the more turbulent the wind pattern in the square.

Conclusions – the square should be designed:

- As small as possible: the bigger square – the windier environment.
- With boundary buildings lower than the surrounding neighbourhood. The more the buildings reach above the neighbourhood – the windier the environment.
- With openings in the middle of the space and with the main axis of the square parallel with the dominant wind direction and the dominant orientation of the surrounding street alignment.

2.5 Design parameters, recommendations and solutions

2.5.1 Design parameters

There are a number of overall parameters to take into consideration when starting to evaluate wind conditions in an open space.

The geographical location, or the climatic zone to which the open space belongs. Is a certain level of wind desirable or undesirable? Is it a windy area where high wind velocities can be expected?

The type of space, e.g. the shape of the space and the characteristics of the surrounding area. Is the space sheltered or located in an open area? Can the surrounding buildings affect the wind pattern in the open space?



Figure 2.4: Square with openings in the middle - width: 10 m, 20 m, 30 m.



Figure 2.5: Square with openings at the corner - width: 7 m, 14 m, 21 m.

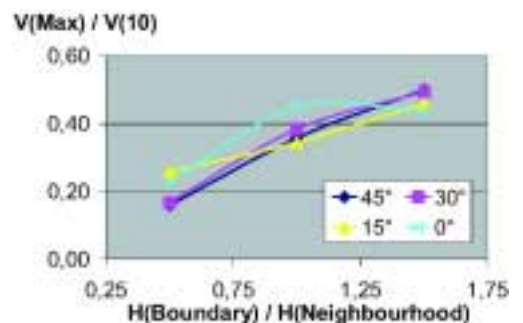

Figure 2.6: V_{Max}/V_{10} as a function of $H_{\text{Boundary}} / H_{\text{Neighbourhood}}$. The lowest wind speed is when the boundary buildings are lower than the surrounding neighbourhood. E.g. V_{Max} is around 20% of V_{10} in this situation.

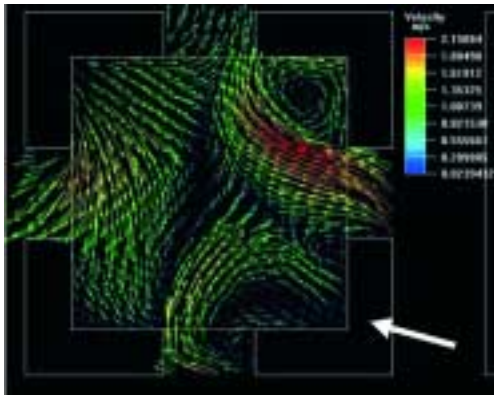
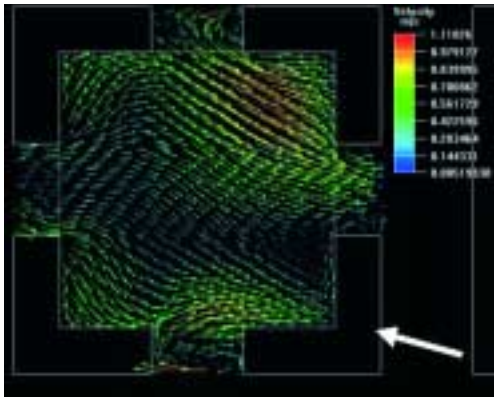

Figure 2.7: Vector plot showing wind direction and speed on the square. Height of boundary buildings: 9 m (top) and 27 m (15° wind direction). The higher the boundary buildings compared to the neighbourhood - the higher is the wind turbulence.

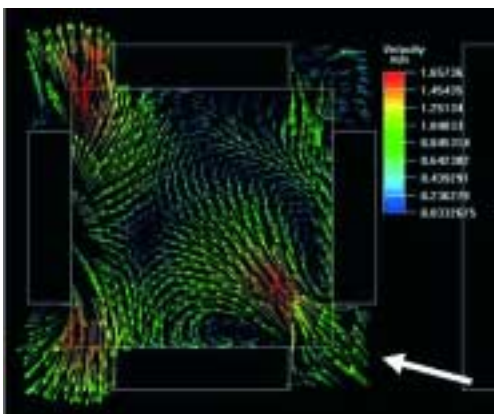
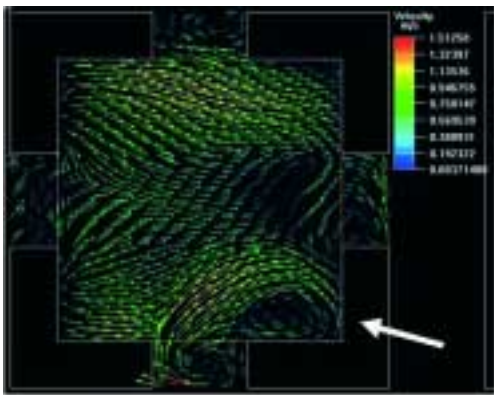

Figure 2.8: Vector plot showing wind direction and speed in the square with a medium sized opening placed in the middle (top) and in the corner of the square (15° wind direction). Openings in the corners give the most turbulent flow pattern.

The last parameter to consider is the type of use, i.e. who uses the space, when is it used and for what purpose? A park is an example of an open space where the users are invited to stay for longer periods, setting high demands for the outdoor environment.

2.5.2 Design recommendations

It is important to treat each space as an individual case. Thus it is difficult to give detailed recommendations for the design of urban spaces. However, it is possible to give recommendations on what the designer should be aware of.

Avoid placing an urban space close to buildings, which are higher than the average height of the surrounding urban area. Such buildings can give rise to an unpleasant vertical wind flow running down the façade of the building (downwash) and to high-speed wind around the corners of the building (Fig. 2.9). The higher the building the higher is the wind speed. The result can be a windy environment around the base and the corners of the building and a horizontal wind flow running away from the building opposite the main wind direction (the Wise effect). Counter measures are first of all to build lower. If the high building can not be avoided then a possibility is to introduce a structure, which can deflect the downwash, e.g. a veranda (Fig. 2.10). Corner effects are difficult to avoid, but at pedestrian level, can be reduced using windbreaks.

Avoid placing an urban space in open connection with long linear streets. Linear urban structures such as buildings can create a channel effect where the wind can accelerate and create an unpleasant environment. The effect can occur when streets are longer than 100-125 m [4]. The effect will be even worse if the streets are forming a funnel (Venturi effect, Fig. 2.11). Counter measures are, e.g. avoid the open connection between the space and the street, make the street shorter (new areas), to avoid constructing the street with the main axis in the dominant wind direction, break up the alignment of the street (curved alignments are not suitable as the wind resistance is small in such streets) and plant up the street to increase wind resistance.

Passages between or under buildings leading to an open space can also form a kind of funnel, where wind can accelerate to create an unpleasant wind environment. This effect can be dramatically worsened in connection with high buildings or long linear streets (see above).

The dimensions of the urban spaces can be designed in such a way that the wind will flow mainly above the space and not into the space creating uncomfortable conditions in the pedestrian zone. This is called the mesh effect [4, 5]. An important factor is the relationship between the area of the urban space and the height of the boundary buildings (or other urban structures such as windbreaks), which can be expressed as:

$$A_{\text{Space}} / (H_{\text{Boundary}})^2 = K.$$

K is a dimensionless constant which should not be higher than 6. It is important that the width of the openings to the space is not larger than 25% of the length of the perimeter of the space. An example is the case of the quadrangle space in Section 1.4, where the $H_{\text{Boundary}} = 18$ m. In this case the maximum area of the square should be $A_{\text{Space}} = 18^2 \times 6 = 1944\text{m}^2$ ($44 \times 44 \text{ m}^2$) and the maximum opening width = $0.25 \times 4 \times 44 = 44\text{m}$. With four openings of the same size this gives a width of $44/4 = 11\text{m}$ per opening. It is preferable that the opening(s) do not face the dominant wind direction. The mesh effect is also valid for other shapes than quadrangle and rectangles. There is a complicated relationship between the wind pattern in the pedestrian zone and the length and width of the space ($L_{\text{Space}}, W_{\text{Space}}$), the height of the boundary structures (H_{Boundary}) and the wind direction. A wind tunnel study of rectangular spaces has shown [6] that with narrow and medium wide spaces

($W_{\text{Space}} / H_{\text{Boundary}} = 1-4$), the optimal length of the space is 4-5 times the boundary height. With wide spaces ($W_{\text{Space}} / H_{\text{Boundary}} = 8$), the optimal length of the space is 6-8 times the boundary height.

Windbreaks can be used to protect the pedestrian zone in an urban space from high wind speeds and turbulence and can be both solid structures (buildings, walls, etc.), or permeable structures (vegetation, open fences, etc.). Solid windbreaks can give good shelter close to the structure, but tend to create high wind velocities and turbulence further away. Thus in most cases it is better to use permeable windbreaks. Vegetation is a very effective windbreaker as branches and leaf will slow down the wind without creating a lot of turbulence (Fig. 2.12). Studies have shown that medium close plant belts give the best and most uniform shelter (50-65% opening area) [7]. It is important that the plant belt give the same shelter in full height, thus it might be necessary to combine different types of vegetation e.g. to use trees to give shelter in height and bushes/scrubs to give shelter close to the ground. Such plant belts can give good shelter in a distance of 4-5 times the height of the belt away from the fence [4]. Permeable fences can also be a good design solution. Studies have shown that fences with 35-40% opening area provide the best shelter [4]. It is important that the holes in the fence are distributed over the whole area of the fence thus several small holes will give a more easy wind pattern than few large holes.

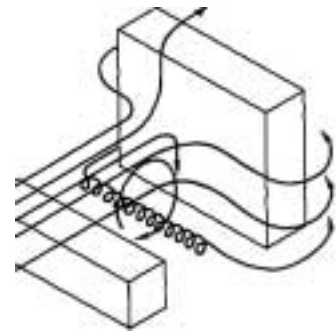

Figure 2.9: Wind pattern around a high and a low building.



Figure 2.10: Example of counter measure for downdraft - veranda on the base of the high building.

2.6 Checklist

- Define the climatic zone, the type of space and the type of use.
- Define the comfort criteria appropriate for the space – criteria might be different for different parts of the space (Table 2.1).
- Set up the wind statistics for the site (average wind speed V_{10}) according to a meteorological station nearby and according to the velocity profile for the surrounding area (Fig. 2.1 and Table 2.2).
- Analyse how the neighbourhood and the space will affect the wind conditions on the space using full scale measurements, wind tunnel tests, CFD calculations or simplified design recommendations (e.g. Sections 2.4 and 2.5).
- Compare the outcome of the analysis with the comfort criteria and change the layout of the space and its surroundings if conditions are not acceptable.

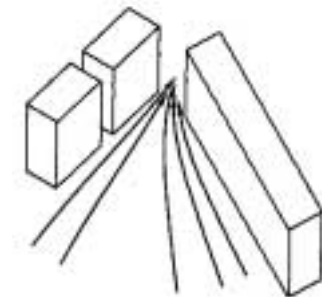

Figure 2.11: A special case of the channel effect - the Venturi effect.

2.7 References

- [1] Penwarden, A.D. and Wise, A.F.E. (1975). *Wind environment around buildings*. Department of the Environment BRE, Her Majesty's Stationery Office, London.
- [2] Bjerregaard, E. and Nielsen, F. (1981). SBI direction 128 *Wind environment around buildings*. (In Danish): Danish Buildings Research Institute, Hørsholm.
- [3] Davenport, A.G. (1972). *An Approach to Human Comfort Criteria for Environmental Wind Conditions*, Swedish National Building Research Institute, Stockholm.
- [4] Houlberg, C. (1979). An introduction to wind environment part II: *Wind and Shelter in Built-up Areas* with commented stock of bibliography for BSA. (In Danish): The Royal Danish Academy of Fine Arts, Copenhagen.
- [5] Gandemer, J. (1977). Wind environment around buildings: Aerodynamic concepts, *Proc.: Fourth International Conference on Wind Effects on Buildings and Structures*, Cambridge University Press.
- [6] Smith, F. and Wilson, C.B. (1977). A parametric study of airflow within rectangular walled enclosures, *Building and Environment*, Vol. 12, pp. 223-230.
- [7] Houlberg, C. (1976). An introduction to wind environment part I: *Living fences and windscreens* with commented stock of bibliography, 2nd edition. (In Danish): The Royal Danish Academy of Fine Arts, Copenhagen.



Figure 2.12: Vegetation as windbreaker.

3. EVALUATION OF RADIANT CONDITIONS IN URBAN SPACES

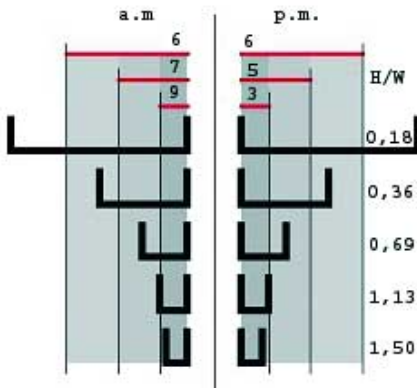

Figure 3.1: Shadow path overlapped to the sections of NS oriented streets.

3.1 Introduction

The revival of interest in the quality of urban open spaces is linked to the emerging needs of people to enhance social life sustained by a comfortable physical environment. Few analytical studies are available to evaluate comfort requirements in relation to specific urban microclimates generated by morphology, materials, water and vegetation, but unfortunately they are either too complex, or not available to common design practice.

Thermal comfort conditions in urban spaces are determined by a combination of social-psychological and physical aspects that have been investigated in the RUROS [1], [2], [3] research project. The physical aspects include adaptation to the local microclimate, as determined by the surrounding physical environment.

Materials of the urban environment, particularly –including building materials, shading devices, vegetation– play an important role in modifying microclimate and thermal comfort conditions. Their surface temperatures influence thermal balance and comfort through radiant exchanges, which are dominant in poorly ventilated environment, the most common conditions in urban spaces at pedestrian level.

While the general effect of building materials on microclimate, in specific urban context and configurations, have been largely analysed in urban climatology (summer and winter heat island effect, albedo distribution, radiant fluxes in canyons, etc.), the effects of particular materials have been only recently investigated [4]. All these studies, however, are not suitable for design purposes, as they are either measures of specific case studies or simulations done with complex programmes.

The aim of the current guidelines is to provide a simplified graphic tool, which allows designers to develop “radiant” sensibility to the design of thermally comfortable urban spaces. In other words, the tool helps designers to evaluate the thermal comfort conditions of the proposed design scheme, giving a variation of the Mean Radiant Temperature (MRT), as a function of the use of different materials (and morphology).

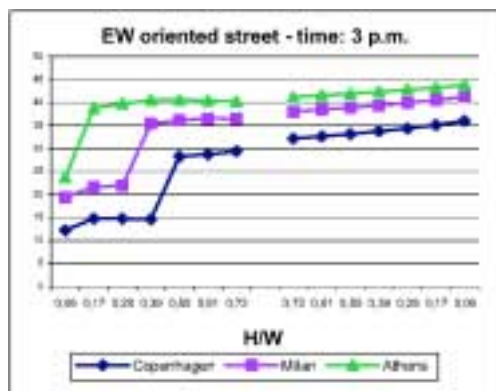

Figure 3.2: MRT values in the reference streets EW oriented.

3.2 Methodology to evaluate radiant conditions

A simplified graphic method to evaluate radiant conditions in urban context has been developed on the basis of computer simulations performed using the software Solene [5]. The output of the method is an approximate evaluation of MRT, which can be easily utilized to calculate comfort indices such as PET or similar [6].

Focus of the research was to investigate the space and time variations of the radiant field according to the use of different materials and their physical properties, which are investigated as the main variable, in newly designed or renovated urban spaces. Three main climatic areas have been considered: north, centre and southern Europe, corresponding to Copenhagen, Milan and Athens respectively.

The reference condition has been defined as the constant value of MRT in an unlimited horizontal plan. A vertical plan (simulating a building façade) modifies the value of MRT around the space depending on size, orientation and materials (Figs. 3.2, 3.3).

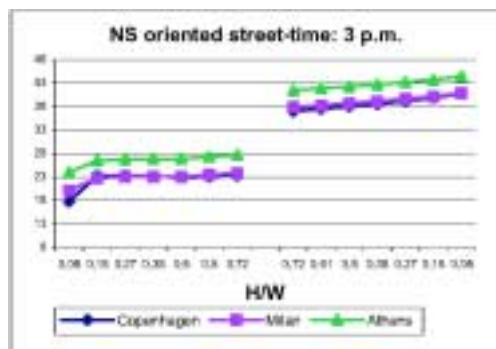

Figure 3.3: MRT trend in the reference streets NS oriented.

The model considers different spatial configurations ranging from a street of infinitive width (with a façade only) to a narrow one, squares to corner effect. Dimensions are given as a Height/Width ratio (H/W).

Simulated variations are referred to:

- Latitude (Copenhagen, Milan, Athens)
- Orientation of vertical element (S-N, E-W)
- Pavement albedo (0.2, 0.8)
- Street size (100, 50, 26, 16, 12 width, 18 height)
- Squares corner effect (all dimensions in m. 30x30, 60x60, 30x60, 60x30, 18 height)

Simulations consider a low wind speed (less than $1.5\text{m}\cdot\text{s}^{-1}$), typical in the urban context in a sunny summer day, as the air temperatures are related to a typical hot day (Table 3.1).

Table 3.1.

Air temperature in five time periods of the day in Milan, Athens and Copenhagen [7]

Air temperature (°C)	Milan	Athens	Copenhagen
Morning	24	26	20
Midday	30.5	33.5	24.5
Afternoon	32.5	37	25.5
Evening	29	33.5	22.5
Night	22	24.5	17

Continuously changing radiant conditions were divided into five periods of “similar” conditions – night, morning, noon, afternoon and evening. For every period the values of MRT in shade or in the sun have been evaluated. In these periods the radiant conditions are considered constant, being the variations controlled by physical and psychological adaptation mechanisms.

Due to different radiation collected, the values of MRT calculated in adjacent areas can change significantly. Average values of MRT are reported in the different tables together with the expected variation in these periods.

3.3 Evaluation criteria

Climatic zones: Three cities have been considered across Europe: Copenhagen (55° Lat.), Milan (45° Lat.) and Athens (37° Lat.).

Type of materials: Materials are grouped into two classes depending on albedo and thermal capacity. Cool materials are normally considered the ones with light colours and high thermal capacity, while daily warm materials are the ones with dark colours and low thermal capacity.

Traditional urban designers usually choose materials on the basis of the different technical requirements, which fulfil specific local needs or uses and legislation in terms of visual perception, safety, health, durability, cost, etc. Environmental requirements are not usually taken into consideration. Thus in order to promote thermal comfort control in outside spaces, it is necessary to associate basic technical requirements with environmental requirements, as presented below.

Radiative control (albedo) with colour, thermal capacity with weight.

The simplified method considers the most used material for the pavement, concrete. This material is defined by its thermal properties,

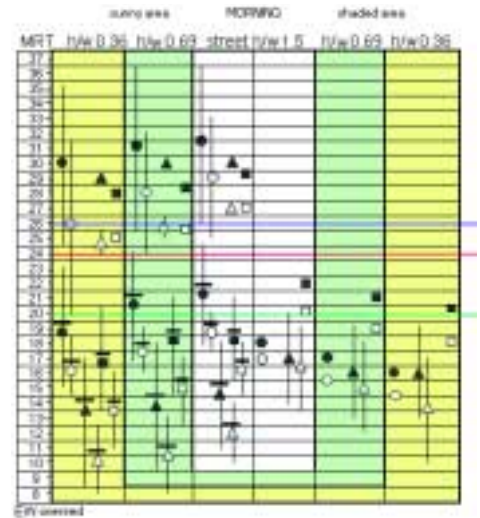

Figure 3.4: Variation of MRT in the reference streets- EW orientation- in the morning.

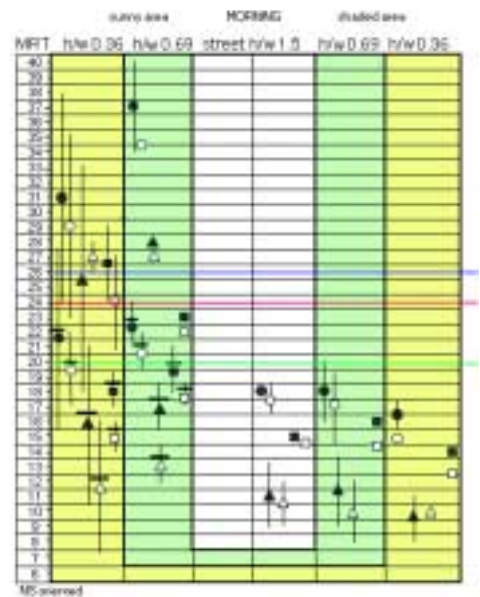

Figure 3.5: Variation of MRT in the reference streets- NS orientation-in the morning.

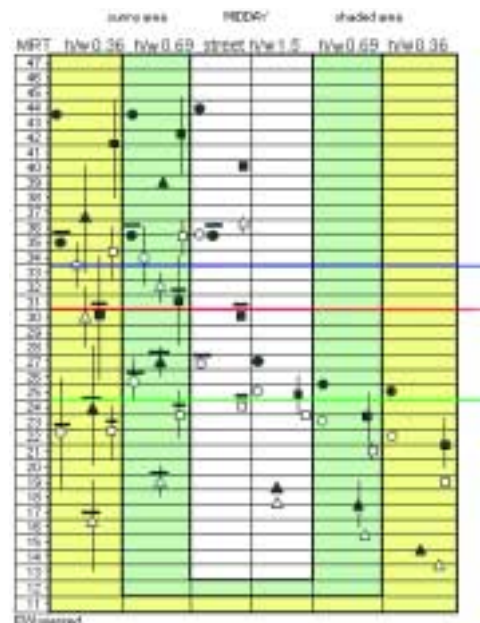

Figure 3.6 Variation of MRT in the reference streets- EW orientation- in the midday.

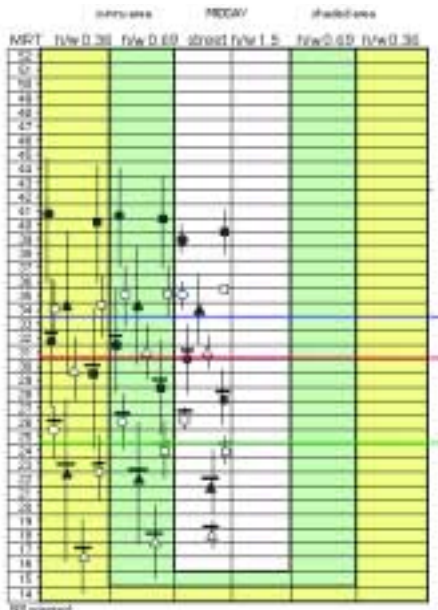

Figure 3.7: Variation of MRT in the reference streets- NS orientation- in the midday.

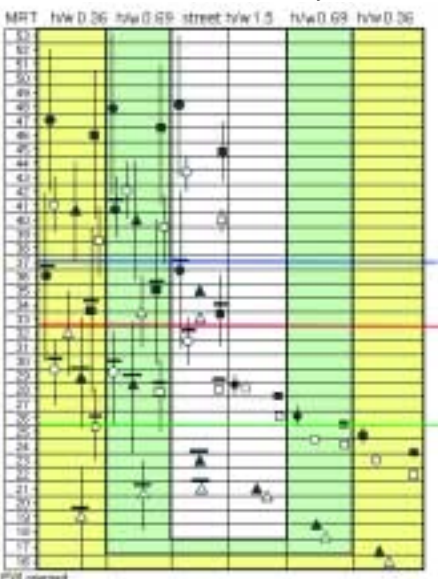

Figure 3.8: Variation of MRT in the reference streets- EW orientation- in the afternoon.

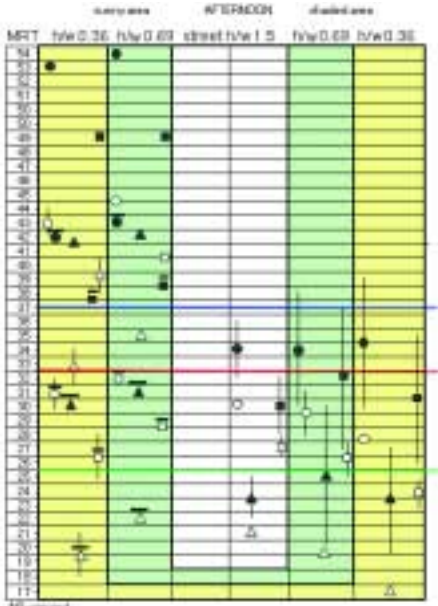

Figure 3.9: Variation of MRT in the reference streets - NS orientation- in the afternoon.

i.e. specific heat ($1000 \text{ J.Kg}^{-1}\text{K}^{-1}$), density (2200 Kg.m^{-3}) and conductivity ($0.9 \text{ W.m}^{-1}\text{K}^{-1}$).

Radiative modification has been considered in terms of albedo. More specifically, a light-coloured material that reflects 80% of incident solar radiation and a dark-coloured that reflects only 20% have been considered (Table 3.2).

Table 3.2.
Classification of materials in three categories in terms of their albedo [8]

	Albedo 0.1 - 0.3	Albedo 0.4 - 0.6	Albedo 0.7 - 0.9
Surfaces	Black asphalt	Clear concrete	Limestone stone
	Dark concrete	Oxidized copper	White marble
	Grass	Red brick	White paint
	Slate	Stone	

Type of space: The simplified method presented is suitable for urban spaces, such as streets and squares. A broad range of W/H ratio streets have been considered from very low, 0.06, where one front does not influence the microclimatic behaviour of the opposite front, to relatively high, 0.72, where both sides of the street have a combined effect on the microclimatic behaviour of the whole section. The interesting effect to evaluate in the squares is the corner effect due to the crossing of the two perpendicular façades that constitute a microclimatic niche. The thermal behaviour of the niche is considered as a variation of the corresponding street (with the same dimensional ratio).

Squares with streets along the façades, i.e. without corner effect, have a behaviour similar to the streets due to the solar access at the sides.

Type of use: The simplified method is appropriate to help designers, allocating activities and equipment in urban spaces, according to the thermal comfort conditions of the space. E.g. “settled” low metabolic activities, such as reading, etc., have different requirements from “displacement” activities, such as walking or jogging, which can also be considered, but in a more critical way [9].

Time: Five time periods have been considered, to cover the variation throughout the day: morning, noon, afternoon, evening and night.

3.4 Vegetation

The two main effects of vegetation are shading short-wave radiation (the majority of deciduous trees have a very low global solar radiation transmissivity in summer, 2-5%) and keeping foliage surface temperature not far from air temperature, which means 20-35 °C below the surface temperatures of commonly used urban materials, such as asphalt, concrete blocks, etc. As a result, the globe temperature under a big tree is usually 15-20 °C below globe temperature of the same unshaded area.

The microclimatic effect of vegetation depends also on growth. Mature trees have a foliage temperature a little below air temperature, while young trees and pergolas have a foliage temperature few degrees above air temperature.

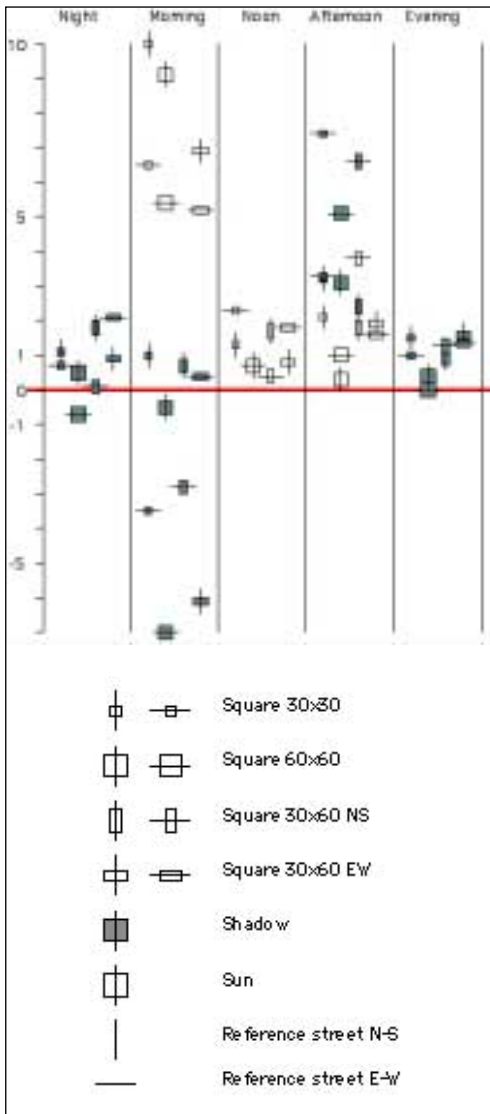

Figure 3.10: Variation of MRT in the centre of the square of different geometry with reference to a street of similar dimensional ratio and orientation.

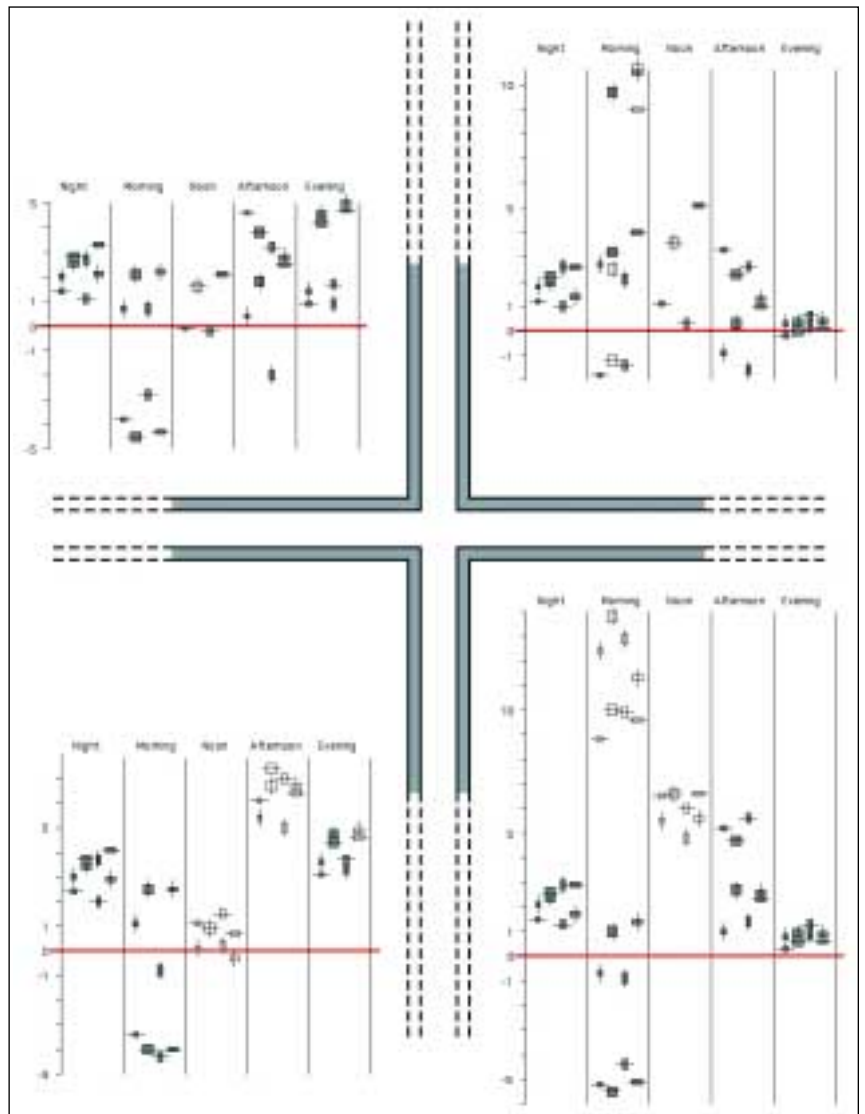

Figure 3.11: Variation of MRT in the corners of a square of different geometry with reference to a street of similar dimensional ratio and orientation.

3.5 Application of the simplified method to evaluate MRT

The graphic method to broadly define thermal comfort conditions in urban spaces is simple to use. The method gives information on the MRT values and their variation for the five periods of the day (Figs. 3.4-3.9 and 3.12-3.15), in a defined period of a summer, sunny day as a function of the following parameters: (i) latitude, (ii) albedo of the pavement, (iii) solar protection and (iv) geometry of the space and (v) orientation.

The steps to apply the procedure are the following:

1. define the latitude of the location under analysis,
2. verify the orientation of the urban space and the sections in terms of H/W ratio,
3. define the period of the day,
4. read in the appropriate graph the approximate MRT value.

The values of MRT and their average variation, as a function of albedo, and local solar protection, can be read from the street graphs (figures 3.4-3.9 and 3.12-3.15).

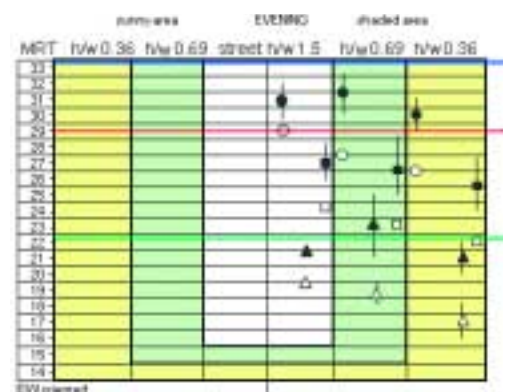

Figure 3.12: Variation of MRT in the reference streets- EW orientation- in the evening.

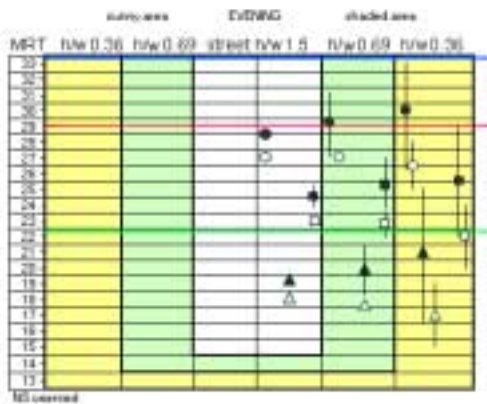

Figure 3.13: Variation of MRT in the reference streets- NS orientation- in the evening.



Figure 3.14: Variation of MRT in the reference streets -EW orientation- at night.



Figure 3.15: Variation of MRT in the reference streets -NS orientation- at night.

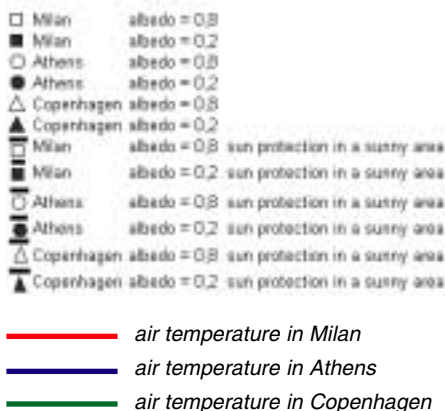

The values of MRT are referred to: i) fully shaded areas, ii) sunny areas and iii) sunny areas where a local protection to direct solar radiation (100%) is provided. Interpolation is possible for different conditions, e.g. solar protection with a 50% transparency. As the values of MRT in a square are different from the ones in a street of similar size, Figures 3.10 and 3.11 report the values of MRT in different areas of the square (in terms of differences from the value of MRT expected in a street with similar size). Four squares have been simulated of different size and orientation; for every square the differences of MRT in 5 points are reported, as microclimatic niches (centre and corners).

E.g. if we consider a street 18H, 50W, NS oriented in Milan the expected MRT value during the morning is around 24°C with a variation of $\pm 3^\circ\text{C}$ in the sunny area and 12.5°C in shade, whereas in the sunny area with a local solar protection the MRT value is $15^\circ\text{C} \pm 1^\circ\text{C}$.

If we consider a rectangular square of 30x60m, 18H, in Milan, the temperature during the morning is expected to be 0.5°C higher in the corner SE (shade) compared to the value of the street of similar size. In the same conditions, in the corner NE the MRT will be 13°C higher.

3.6 Legislation (guidelines)

2001. TOROC (Torino Organising Committee XX Olympic Winter Games) - Linee guida di sostenibilità nel progetto, nella costruzione e nell' esercizio dei villaggi olimpici».

2003. ITACA. Protocollo ITACA (Istituto per la Trasparenza, l'Aggiornamento e la Certificazione degli Appalti)- Gruppo di lavoro interregionale in materia di bioedilizia. "Protocollo ITACA" per la valutazione della qualità energetica ed ambientale di un edificio.

3.7 Checklist

- Microclimatic niches
- Radiant condition
- Albedo of pavement
- Morphology

3.8 References

- [1] Nikolopoulou, M. and Steemers, K. (2003). Thermal comfort and psychological adaptation as a guide for designing urban spaces, *Energy and Buildings*, Vol. 35, No.1.
- [2] Katzshner, L. (2002). Bioclimatic characterization of urban microclimates for the usage of open spaces, *Proc.: Architectural and Urban Ambient Environment*, Nantes.
- [3] Scudo, G., Rogora, A. and Dessi, V. (2002). Thermal comfort perception and evaluation in urban space, *Proc.: EPIC 2002 AIVC*, Lyon.
- [4] Asaeda, T. and Ca Thanh, V. (1996). Heat storage of pavements and its effect on the lower atmosphere, *Atmospheric Environment*, Vol. 30, No 3.
- [5] SOLENE++ *Guide d'Utilisation*, Laboratoire CERMA, École d' Architecture de Nantes.
- [6] Dessi, V. (2001). Evaluation of microclimate and thermal comfort in open space, *Proc.: 18th Passive and Low Energy Architecture (PLEA) International Conference*, Florianópolis.
- [7] <http://www.meteotest.ch>
- [8] Santamouris M. and Doulos L. (2001). *Comparative Study of Almost 70 Different Materials for Streets and Pavements*, M.Sc. Final Report, University of Athens, Department of Physics, Athens.
- [9] Dessi, V. (2002). People's behaviour in an open space as design indicator – comparison between thermal comfort simulation and users' behaviour in an open space, *Design with the environment*, Proc.: 19th Passive and Low Energy Architecture (PLEA) International Conference, Toulouse.

4. URBAN MORPHOLOGY

4.1 Introduction

Research at the Martin Centre in Cambridge has shown that through the innovative application of image processing techniques to three-dimensional urban textures, connections can be made at a simplified level between urban form and microclimatic characteristics. More specifically, urban form parameters were derived using image processing techniques, which were found to be useful for exploring the correlations between urban form and various aspects of environmental performance with respect to the solar and wind environments, and energy consumption. This opens up the possibility of a significant advance in assessing urban microclimates and in being able to evaluate, without the need for elaborate models, the environmental impact of alternative urban forms and proposals for change.

The environmental parameters that have been identified as playing a major role on the comfort in the urban context at a neighbourhood scale are those that are directly affected by the microclimatic alterations that urbanisation causes. The key microclimatic factors include temperature (heat island effects), solar exposure, wind movement, the acoustic environment and urban noise propagation. Urban morphological analysis can primarily contribute to temperature, sun and wind analysis, as well as providing insights in to noise propagation issues.

4.2 Urban Morphology

When we talk of ‘urban morphology’ we simply mean the three-dimensional form of a group of buildings and the spaces they create. The main reason for working with this way of looking at urban form is that it enables designers and planners to understand the consequences of strategic design, without getting lost in the questions of architectural detailing. Urban morphology is of first-order significance on the outdoor microclimate.

In describing urban morphology we will be using a range of descriptors of form that allow us to link with environmental performance. For example, we can discuss the influence of building geometry on sunlight, wind or noise in the open spaces. The purpose is not to describe the detailed physics or the complexity of phenomena but to define simple relationships.

4.3 Morphological Parameters and their influence on Urban Open Spaces

4.3.1 Introduction

A range of geometric parameters and their relationship to the urban microclimate are discussed below. The focus is on the morphological factors that have an impact on outdoor comfort. A collection of morphological parameters is listed in Figure 4.4, which also outlines the information flow between the various image processing maps and how these are overlaid and combined to inform the design process. For the purpose of these guidelines, All Saint’s Garden in Cambridge, UK has been selected as a case study for this discussion of urban morphology. Using a 3D model (Figure 4.1), Digital Elevation Model (DEM) (Figure 4.2), Figure Ground Map (Figure 4.3) and geographic and microclimatic data as input, outputs such as annual plots of sky view factor, solar shadowing and wind shadowing can be produced and



Figure 4.1: 3D Model of All Saint's Garden, Cambridge.

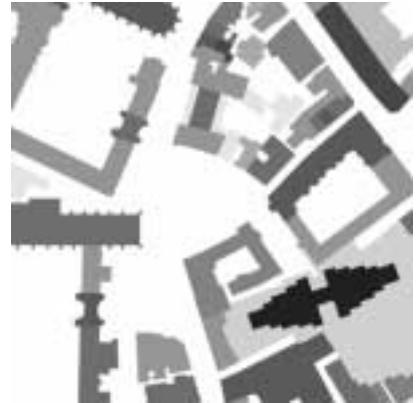

Figure 4.2: Digital Elevation Model (DEM). A greyscale 2D image with values ranging from 0 (black) to 255 (white), where black and white correspond to the highest and lowest heights of the area, respectively.



Figure 4.3: Figure Ground Map. A black and white image where black (0) corresponds to built-up area while white (1) corresponds to open space.



Figure 4.4: Sky View Factor Map. Lighter shades of grey correspond to higher sky view factors. (Matlab algorithm by Ratti [1]).

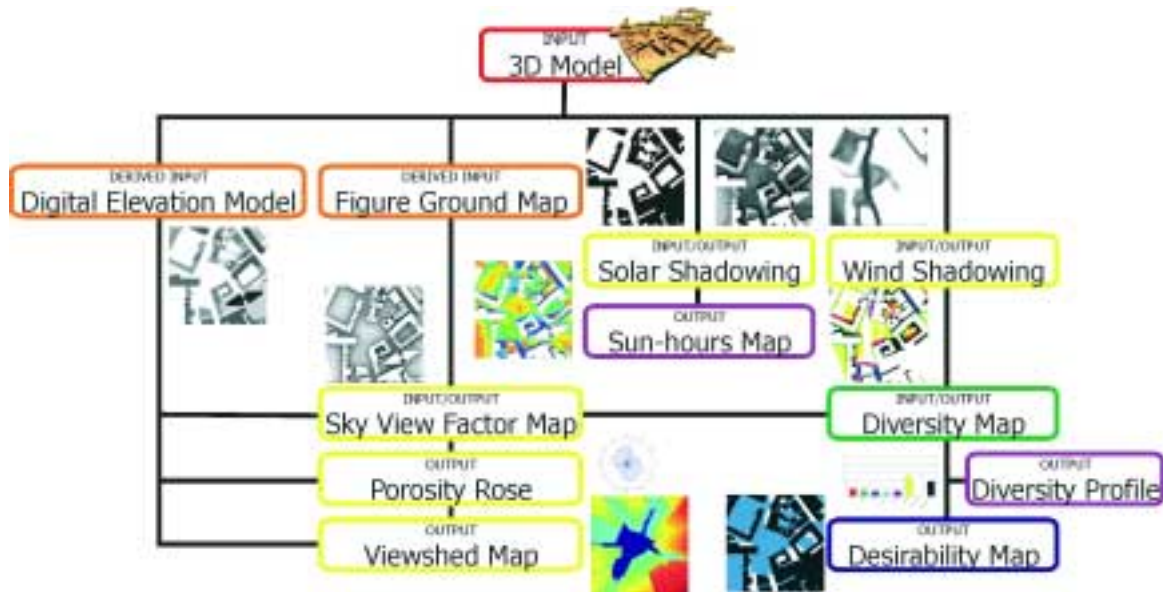

Figure 4.5: Flowchart of the Urban Morphological Analysis Process.

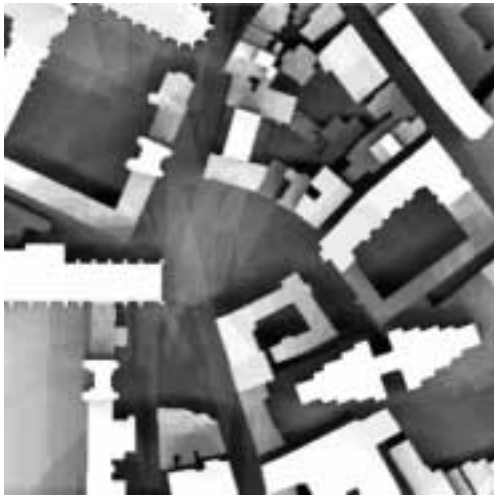

Figure 4.6: Solar Shadowing Map. Darker shades of grey correspond to areas that are predominantly in shadow on an annual average.

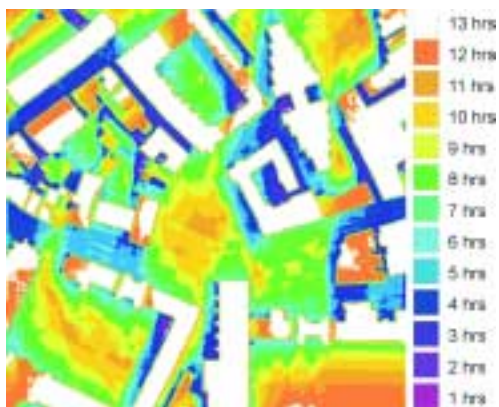

Figure 4.7: Sun-hours Map. Derived from the Solar Shadowing Map (Figure 4.6), each colour corresponds to the average hours of sunlight each area of the site receives.

further analysed in order to characterize open spaces and identify areas that require design intervention. This characterization can also aid in the formulation of design strategies which address issues relating to urban morphology and microclimate.

4.3.2 Sky View Factor

Sky View Factor (SVF) is simply a measure of solid angle of view of the sky from an urban space. It determines the radiant heat exchange between the city and the sky. A SVF of 1 means there is an unobstructed view of the sky – e.g. from an open field – and thus temperatures will closely follow meteorological values. A SVF of 0 means that the view of the sky is totally obstructed, and thus the temperatures will be strongly influenced by the urban context. Thus one would expect the SVF in a medieval town with narrow streets to be high – maybe about 0.2 – whereas in a more open urban environment, with large wide streets and spaces, the SVF may be nearer 0.8. In any given city there may be typical SVF values that determine overall temperature variations from the meteorological data, but there may also be significant variations of SVFs within the urban fabric.

A mapping of the sky view factors for our case study site is illustrated by Figure 4.4. In terms of design, sky view factor is directly related to the urban heat island effect [2], and strongly affects temperature variations in the urban environment. Generally, lower sky view factor implies an increase in the urban heat island effect, although other factors, such as the need for shade that can be addressed by the shadowing provided by narrow streets, must also be considered.

SVF can be expressed as summertime resultant temperature swing and shows the more stable thermal environments (black areas have a lower temperature swing) compared to those that follow synoptic conditions more closely (higher temperature swing). In the more stable environments, particularly the deep courtyards, the summer daytime temperatures have been measured as cooler than ambient, confirming the presence of urban cool islands. However, night time temperatures in such occluded spaces are warmer than ambient and adhere to the urban heat island intensity as defined by Oke [2].

Visually, a higher sky view factor provides the feeling of ‘openness’ in outdoor space, a value that has emerged as an important factor for people using outdoor open spaces.

4.3.3 Solar Shadowing and Sun-hours

Mapping solar shadowing involves plotting the shadows for each hour of the day, for a day each season, and overlaying these images to create an annual shadow casting profile of the site. This solar shadowing map is shown in Figure 4.6. Solar access and solar shadowing are important considerations in design, particularly when considering solar radiation and daylighting. Because solar radiation has a significant impact on thermal comfort, the degree of availability of sun and shade as represented by a threshold value for hours of shade is a simple indicator of spatial diversity.

From the shadow casting image it is possible to show how many hours of sun any part of the urban area receives. In order to simplify the image one can generate contour maps (Figure 4.7), establish threshold values and from this define zones of predominantly sunny or shady conditions.

4.3.4 Porosity and Wind Shadowing

Wind flow is another important parameter to consider in the design of urban spaces. Wind can be considered as a positive or negative factor, depending on the general climate of the area, and the season. Because it is quite a perceivable element of the urban microclimate, it greatly affects thermal comfort.

To study the behaviour of wind flow in cities we set up a simple virtual wind tunnel to map wind flow from 12 different directions, and overlaid these into a single map (Figure 4.8), each 'wind snapshot' assigned a transparency proportional to its directional percentage frequency, taken from a wind rose. Thus, a wind shadow generated by the prevailing wind direction will be more significant than a wind shadow created from a less significant direction. For this project we use the wind speed/frequency rose for Cambridge in order to map wind shadows (Figure 4.9). The map illustrates areas on the map which are predominantly still compared to those predominantly exposed to wind.

The Porosity Rose in Figure 4.10 is yet another indicator of wind flow and circulation within the site, by measuring the obstructions created by the built-up areas in each direction. A higher degree of permeability in a certain direction indicates pathways where wind can travel, and when it coincides with the windroses, can give an indication of wind speeds and clearing efficiency.

4.3.5 Field of View

The Viewshed Map (Figure 4.11) is simply an illustration of the surfaces that can be viewed when standing in the middle of the site. This mapping of one's field-of-view is a useful design tool when considering the visual stimuli a user experiences when standing in an urban space.

4.3.6 Environmental Diversity

When designing urban open spaces one important thing to remember is that it is better to create a variety of environmental conditions, as this is the natural state of things in outdoor spaces [3]. By doing so, we will be able to create a diverse range of favourable environmental conditions which are designed to address a wider range of personal preferences.

The interaction between the various urban morphological parameters create a unique diversity profile for each site, and we shall use RGB image processing to overlay sky, sun and wind maps to give a sense of potential environmental diversity in an urban context. The grayscale maps for sky view factor (Figure 4.4), solar shadowing (Figure 4.6) and wind shadowing (Figure 4.8) reduced to threshold values and assigned to the RGB channels of a RGB colour image (Figure 4.12).

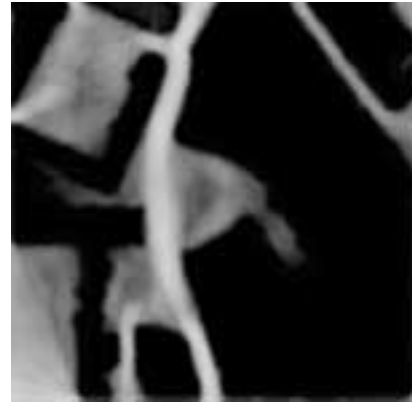

Figure 4.8: Wind Shadowing Map. Obtained from wind simulation snapshots of 12 different wind origins, this map shows the annual average frequency of wind flow. Darker areas correspond to areas with less wind.



Figure 4.9: Wind roses for Cambridge, UK.

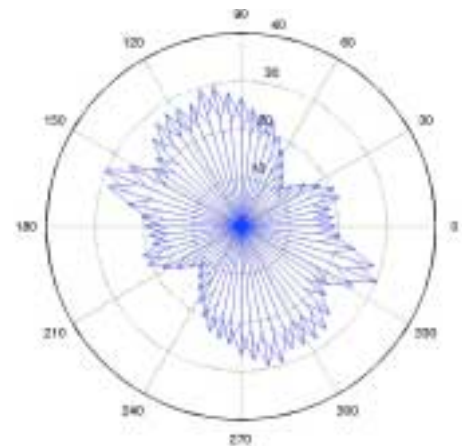

Figure 4.10: Porosity Rose. Illustrates the permeability of the area by calculating the obstruction value of the buildings along all directions (Matlab algorithm by Ratti [1]).



Figure 4.11: Viewshed Map. A mapping of the field of view from the middle of the site. White areas correspond to areas and surfaces within the person's potential line of sight (Matlab algorithm by Ratti [1]).



Figure 4.12: Sky, Sun, and Wind Threshold maps used as RGB channels for the Diversity Map (Figure 4.13).

The resulting map (Figure 4.13) indicates that an intricate mix of environmental conditions is available. The graph of area distribution for the various environmental profiles shows that the site has a predominance of still-sunny and lots of sky-sun-wind conditions: quite appropriate for the English climate, particularly as there is still some availability of still-shady as well as windy-sunny areas. For a climate which is temperate, the almost complete lack of windy-shady areas within the open space itself is not of great concern, but on exceptionally hot days, which are predicted to increase as a result of climate change, it may present noticeable limitations on comfort. Remedial measures such as the introduction of shading and evaporative cooling from trees and water features will be a way of improving the situation. Additionally, one could conceive of enabling access to intermediate spaces with the appropriate thermal characteristics such as: high thermal mass, orientated to prevailing winds to encourage air movement, northerly aspects, etc.

Such environmental diversity maps can be produced for any climate, site or season in order to explore relative characteristics. The analysis can be more or less detailed, although the amount of information contained even in the relatively simple maps presented here is probably at the limit of practical value. The main purpose of such maps is to indicate the relative degree of environmental diversity as a function of urban form. The assessment of environmental diversity in the form of the range and amount of diverse thermal conditions available will need to reflect the climatic context. One might refer to 'appropriate diversity' where negative factors are reduced and positive conditions are increased. In a hot-arid climate one would aim to have more shade and thermal stability, whereas in a warm-humid climate wind and shade are critical. In a cold context, sun and still conditions should predominate. Similarly, in climates where there a strong seasonal variations, it is possible to define certain spaces as having conditions appropriate primarily for summer, and others for winter use. However, common to all climates or seasons is that there is an advantage in having an appropriate range of conditions available, in order to increase freedom of choice.

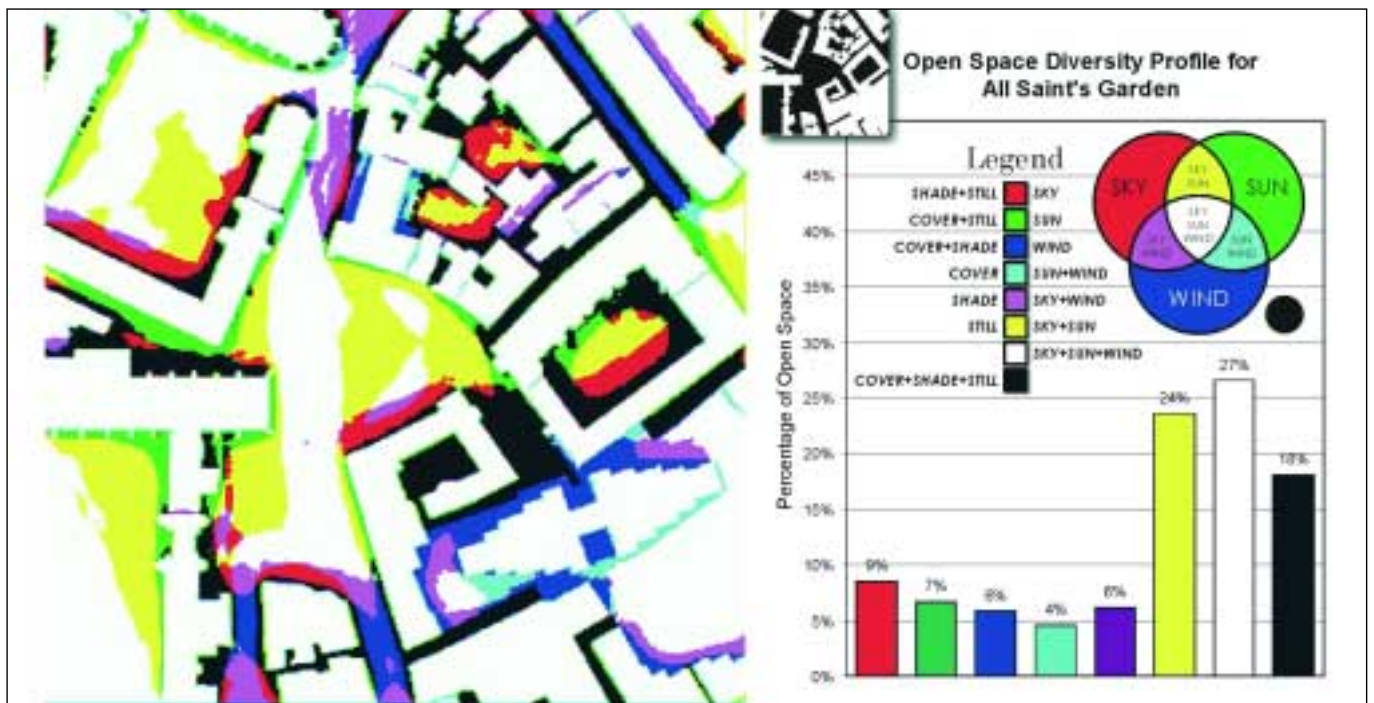

Figure 4.13: Open Space Diversity Profile. Image on the left shows the resultant overlay between threshold maps of sky view factor, solar shadowing and wind shadowing. Graph shows the distribution of the various environmental combinations present at the site.

4.3.7 Desirability

To take the analysis further, a ranking of various environmental combinations was generated, based on a methodology put forward by Brown and de Kay [4]. In this book, a set of recommended values for individual microclimatic variables were identified per climate and per season. These were then added to each other to create a score for the various combinations of sun, shade, still and wind. We have adapted this table to include scoring for sky and cover, and, selecting a climate classification appropriate for Cambridge, generated the ranking of environmental combinations in Table. 4.1. Based on this ranking, the desirability of the different bits of open space may be mapped on an annual or seasonal basis (Figure 4.14). These maps give an indication for positive areas for development and identifying areas that require design intervention, particularly the darker blue zones. Based on these rankings, the desirability of the different bits of open space may be illustrated (Figure 4.14). These maps give an indication for positive areas for development, and identifying areas that need design intervention, particularly for darker blue zones that lie within the open space under study. A complete table of rankings may be found in the Urban Morphology component of the RUROS final report.

4.4 Software

The following is a listing of software types and some corresponding examples of software packages that can be used to generate the images and perform the analysis outlined in these guidelines:

Table 4.2.
Software types used for Urban Morphology Analysis

Task	Software type	Example
3D modeling	Computer-aided design and drafting	AutoCAD
DEM and Figure-Ground Generation	3D rendering, image processing	3D Studio MAX, Maya, Lightwave, Adobe Photoshop, Corel PhotoPaint, Matlab
Sky View Factor, Porosity, Rose, Viewshed Map	Image Processing and Analysis [1]	Matlab
Solar Shadowing, Sun-hours Mapping	3D rendering or Image Processing	3D Studio, Maya, Lightwave, Matlab, Adobe Photoshop, Corel Photopaint
Wind Shadowing	CFD, Physics Simulation	Flovent, Fluent, Maya, 3D Studio MAX
Diversity and Desirability Mapping	Image processing	Matlab, Adobe Photoshop, Corel Photopaint

4.5 Conclusion

There is limited value in defining or attempting to achieve optimum thermal conditions in the urban environment. More importantly, the success of an urban environment can be assessed in terms of environmental diversity. The aim is thus to maximise appropriate diversity and thereby maximise choice in relation to the climate, activities and preferences of the user.

4.6 References

- [1] Ratti, C. (2001). *Urban analysis for environmental prediction*, PhD Dissertation, University of Cambridge.
- [2] Oke, T. (1987) *Boundary Layer Climates*, 2nd ed., Routledge. London.
- [3] Proshansky, H.M., Ittelson, W.H. and Rivlin, L.G. (eds.) (1976) *Environmental Psychology: People and their physical settings*, Holt, R. and W., New York.
- [4] Brown, G.Z. and DeKay, M. (2001). *Sun, Wind & Light: Architectural Design Strategies*, John Wiley and Sons, New York.

Table 4.1.
Rankings of Environmental Profiles for Cambridge, UK

ENVIRONMENTAL PROFILE	W	A/Sp	Su	An
SHADE + STILL + SKY	-1	-1	-1	-1
SUN + STILL + COVER	1	1	-3	3
SHADE + WIND + COVER	-3	-3	1	-2
SUN + WIND + COVER	3	0	3	3
SHADE + WIND + SKY	-2	-2	2	-1
SUN + STILL + SKY	2	2	-3	1
SUN + WIND + SKY	1	1	1	1
SHADE + LEE + COVER	-2	-2	-2	-2

+3 – best condition
-3 – worst condition

Adapted from Brown, G.Z. and DeKay, M., 2001 [5]



Figure 4.14: *Desirability Map.* (Top to Bottom: Summer, Winter and Annual Mapping) Seasonal and Annual desirability mapping based on the Diversity Profile (Figure 4.13) and a ranking of general preferences (Table 4.1). Darker areas indicate a lesser degree of desirability.

5. THERMAL COMFORT MAPPING AND ZONING

5.1 Introduction

The methodology for bioclimatic comfort mapping is presented, dedicated very much to the need of urban decision makers, planners and architects. The comfort maps refer to an urban environment at the scale of neighbourhood and aim to assist in predicting and assessing bioclimatic conditions, use of space and influence of urban design, by:

- focusing on spatial analysis of thermal comfort zones within a site,
- facilitating the comparison of thermal comfort condition between different sites,
- enabling the comparison of thermal comfort condition between different design conceptions,
- giving information on the connection between thermal comfort and use of space.

As mentioned in previous chapters of this guide, the acceptance and use of open spaces is influenced by the microclimatic conditions offered to people. The microclimate, as well as the thermal sensation, have a strong dependency on the urban design and show a high temporal and spatial variation. So there is a need for knowledge on designing open spaces with climatic consideration.

Thus, the question raised is how to assess thermal comfort conditions in connection with behaviour of people, use of space and urban design. Bioclimatological indices such as PMV or PET [1], predicting the average thermal sensation, based on meteorological parameters as well as clothing and activity of people can be used. Unfortunately the calculation of these indices in the context of microscale urban environment is a task to be carried out by experts and (in practice) often a question of time and cost. E.g. in order to receive a spatial pattern of PET, detailed information on meteorological conditions of an open space is needed, which has to be collected from field surveys or to be calculated by computer simulations. These disadvantages give ground to think about providing urban designers, planners and decision makers with alternative adequate techniques or tools for assessing different planning scenarios in terms of thermal comfort conditions and use of space.

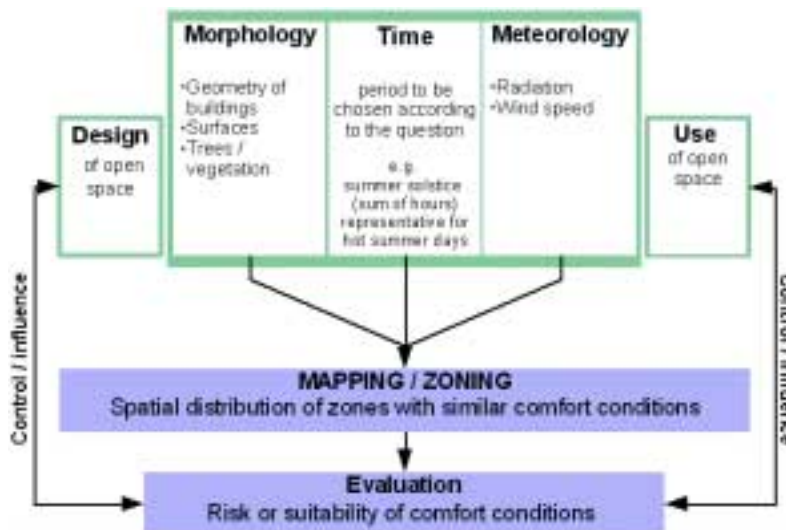

Figure 5.1: Basic structure of thermal comfort zoning.

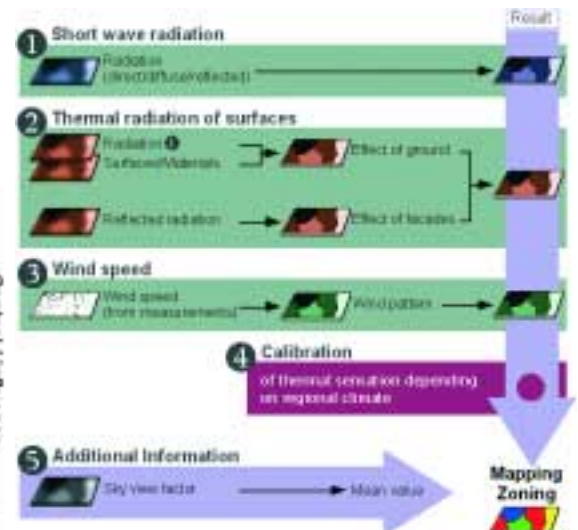

Figure 5.2: Method of thermal comfort zoning.

5.2 Methodology of comfort mapping

The methodology for mapping thermal comfort conditions in the urban context has been developed on the basis of field survey results, whereas the mapping procedure itself does not necessarily require such data.

5.2.1 Field surveys

The surveys involved environmental and human monitoring (i.e. meteorological measurements of the thermal environment as well as interviews and observations on peoples' perception and behaviour), for several public open spaces across Europe.

Thus, from the field surveys extensive information has been obtained on the spatial and temporal variation of climatic parameters and comfort indices (e.g. PET) as well as on comfort evaluation and use of space within the sites [2]. Overall, a close connection between people's behaviour, morphological structures and thermal comfort was shown. From these the development of the mapping methodology and additionally, the evaluation of thermal comfort conditions as well as accompanying planning advices could be derived.

5.2.2 Mapping procedure

Figure 5.1 shows the basic structure of the thermal comfort zoning process developed. The most important aim is to focus on an easy-to-use and easy-to-understand tool addressed and dedicated to the special interest and needs of planners and architects. Consequently, three main influencing issues are taken into consideration:

- morphology of the site,
- meteorological parameters and
- time parameters.

Concerning meteorological parameters there is a focus on solar radiation and wind speed. These two aspects have a high spatial and temporal variation, e.g. causing different comfort conditions within one site at the same time [3, 4]. Air temperature and vapour pressure are more homogeneous, so they become important in the context of «calibration» and evaluation.

Concerning time parameters, the analysis is concentrated on specific periods of time, to be defined depending on the underlying questions.

Finally, a spatial distribution of zones with similar comfort conditions is given, followed by an evaluation in terms of risk or suitability.

The issues of design and use of open space are considered as influencing factors/variables acting in two different «directions»; on the one hand they influence the mapping and evaluation results, on the other hand the evaluation can cause the need for changes/adaptation in design, use of space, etc.

Figure 5.2 presents the mapping procedure in more detail. As mentioned before, solar radiation and wind are the most influential meteorological parameters. Regarding the morphological structure and kind of surfaces, these issues can be analysed (using different tools) and classified. E.g. short wave radiation can be calculated by TOWNSCOPE software [5]; thermal radiation can be derived from global radiation in combination with surface characteristics, while reflected radiation from surrounding façades is an important indicator. The combination of the three thematic maps delivers a thermal zoning which has to be calibrated according to the regional climate. With that

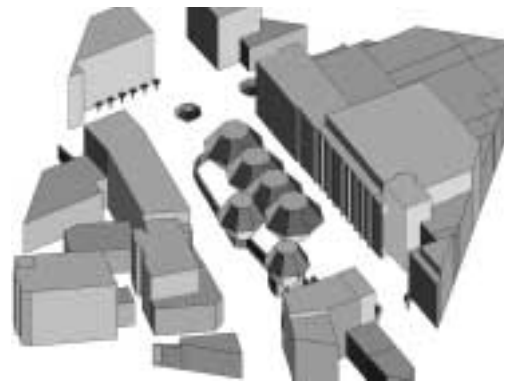

Figure 5.3: Case study site Florentiner Platz (view from WSW).



Figure 5.4: Case study site Bahnhofplatz (view from WSW).

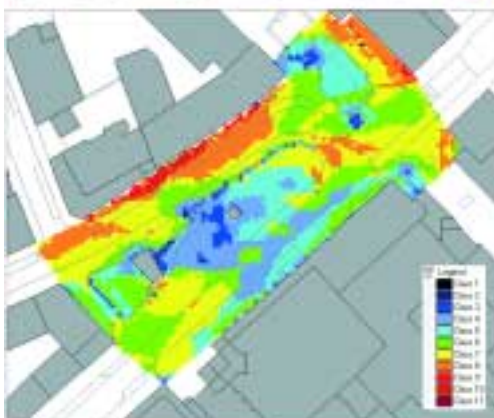
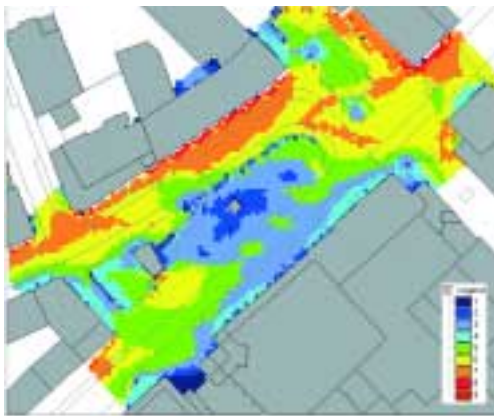

Figure 5.5: The thematic layers "radiation" and "wind" as well as the resulting "thermal comfort zoning" for Florentiner Platz.

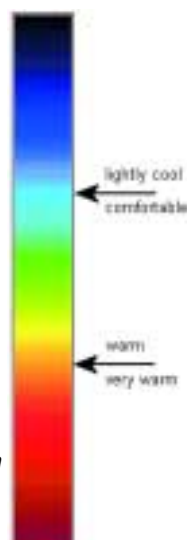

Figure 5.6: Relationship between thermal comfort classes and thermal sensation, for Kassel, referring to on site activities.

there is the possibility of applying the methodology to different climatic zones. An additional consideration of the sky view factor gives important information and assistance in interpreting the comfort conditions in the course of the year or day.

In comparison to the calculation of bioclimatic indices such as PET, the described methodology is quite simple, and seems to be appropriate in order to include the consideration of climatic aspects in the planning process on a frequent basis.

5.3 Application of comfort mapping methodology - Results

In the following the above described theoretical approach shall be illustrated by presenting the mapping results for two sites in Kassel (central Germany): Florentiner Platz and Bahnhofsplatz. Both sites are situated in the city centre of Kassel, but they differ considerably in size, proportions and vegetation (Figs. 5.3 – 5.4).

The mapping procedure has been carried out using different software packages and a GISystem.

5.3.1 Thermal Comfort Maps

The thermal comfort zones derive from the thematic layers «radiation pattern» and «wind pattern». Figure 5.5 shows the respective maps and the emerging comfort zoning for the Florentiner Platz, referring to a sunny day on summer solstice. The thermal comfort conditions are described by a range of several classes, representing areas with similar comfort conditions and thermal sensation. The relationship between the classes and the respective comfort vote depends on the regional climate, according to a certain type of use. For Kassel, this has been fixed from the field survey results referring to on site activities, such as sitting, standing, etc. (Fig. 5.6).

Concerning the interviewees' perception and evaluation as well as use of space, it can be stated from the field surveys, that people (in Kassel - Germany) like to have a certain degree of physiological (heat) stress. Sunny areas (with PET values > 22°C) have been requested and are preferred for most part of the year. Only during really hot summer days an increased number of people complained about discomfort, while the comparatively cooler (shady and windy) zones became busy and were evaluated as comfortable.

In Figure 5.7 the comfort zoning for Bahnhofsplatz is given. In comparison to the Florentiner Platz the completely different morphology causes more homogeneous and warmer conditions.

5.3.2 Evaluation

As described above, from the thermal comfort maps it is apparent how the thermal conditions vary within one site. Considering and overlaying the existing use of space pattern allows evaluation of it. E.g. in case of Florentiner Platz the location of the café (under big trees in the «blue mapped» centre of site) is not very well-suited to the thermal comfort conditions. But considering and evaluating the climatic pattern of the whole site it has to be emphasized that the occurring range and frequency of different comfort classes is quite high and well balanced, as can be seen from the statistical analysis in form of histogram graphs (Fig. 5.8). The existing inhomogeneous structure allows for different activities of potential users and offers the possibility to choose between different thermal conditions, whereas for the Bahnhofsplatz the situation is more homogeneous.

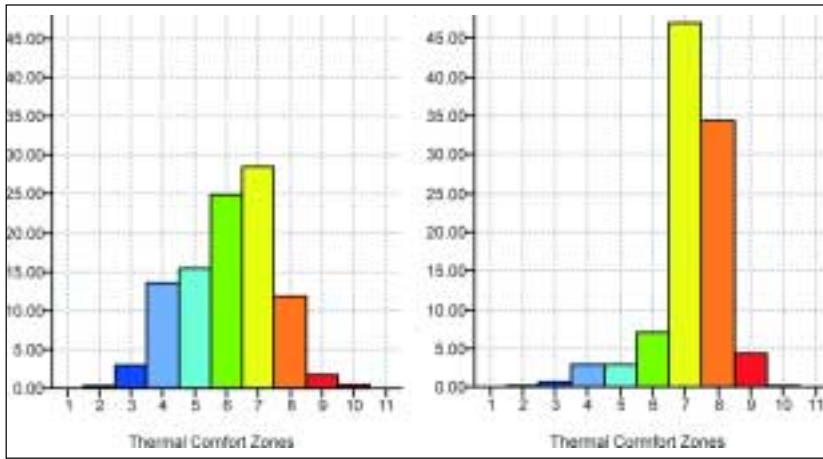

Figure 5.8: Histogram for Florentiner Platz (left) and Bahnhofplatz (right).

This kind of analysis is informative once more, when relating the statistics to areas suitable, exclusively for staying, sitting activities, etc. (i.e. excluding areas for traffic). Figure 5.9 presents the results for both, Florentiner Platz and Bahnhofplatz, where it becomes apparent that the potential of the two sites in terms of thermal comfort is different.

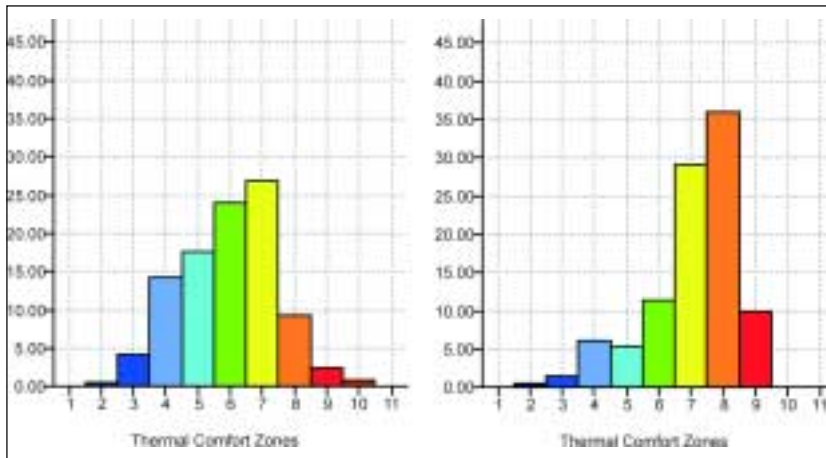

Figure 5.9: Histogram for Florentiner Platz (left) and Bahnhofplatz (right) - leaving aside traffic areas etc.

In this context the definition of an «ideal urban climate» is worth mentioning: «[...] is an atmospheric situation within the UCL with a high variation in time and space to develop inhomogeneous thermal conditions for man within a distance of 150 m. It should be free from air pollution and thermal stress considering the differences in regional climates by means of more shadow and ventilation (tropical and warm climates) or wind protection (moderate and cold climates)» [6].

5.3.3 Characterization via Sky View Factor

Figure 5.10 presents the computation of the sky opening for Florentiner Platz and Bahnhofplatz (calculated by TOWNSCOPE software). The mean sky view factor (SVF) for the comparatively small Florentiner Platz with several old big trees in its centre is 36%, whereas for the Bahnhofplatz, it is 58%. In addition to the thermal comfort maps, this difference informs about the thermal comfort conditions in the course of day or year. The higher the SVF, the bigger the thermal difference between night and day, or summer and winter. Consequently, Florentiner Platz has more even thermal conditions than Bahnhofplatz.

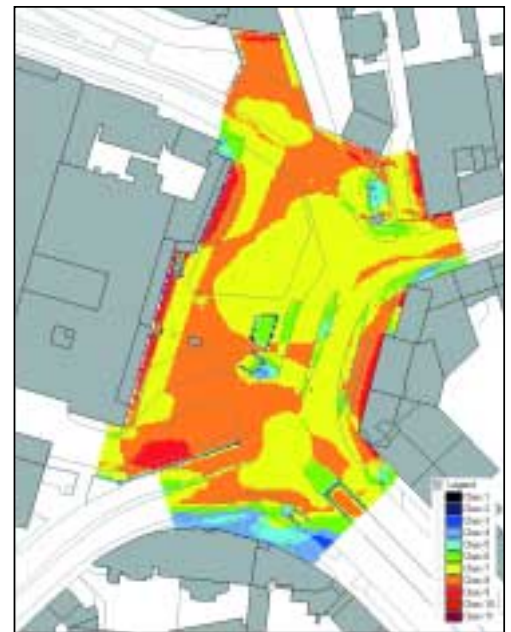

Figure 5.7: Thermal comfort zoning for Bahnhofplatz.



Figure 5.10: In comparison: SVF of Florentiner Platz (mean: 0,36) and Bahnhofplatz (mean: 0,58).

5.4 Conclusions

A methodology for drawing microclimatic thermal comfort maps is available, which can be applied to any site in a relatively simple and effective way. From the comfort maps a comparison and assessment between different alternative design conceptions can be achieved, which follows the needs of urban planning and related fields. Moreover a characterisation and assessment of different city structures, as well as climatic and urban patterns, can be derived.

The thermal comfort maps show in detail the way that urban structures, materials and vegetation have an effect on thermal comfort. Concerning the planning and designing of open spaces, radiation can be influenced mainly by city structures, vegetation, materials and colours, whereas wind, as second dominating factor for thermal conditions, can be channeled or reduced with the use of vegetation.

The mapping procedure can be used in different kinds of urban planning processes, especially at the scale of neighbourhood and open space planning. In terms of German legislation, there are no specific standards, but several general requirements and guidelines for including climatic aspects in planning. Thus, the methodology for mapping thermal comfort is an appropriate and useful addition/tool towards designing comfortable open spaces.

5.5 Legislation

BauGB. Baugesetzbuch (Federal Building Code)

VDI 3787/1. Environmental meteorology - Climate and air pollution maps for cities and regions.

VDI 3787/2. Environmental meteorology - Methods for the human-biometeorological evaluation of climate and air hygiene for urban and regional planning at regional level - Part I: climate.

5.6 Checklist

- Spatial radiation analysis through shadow diagrams and distances from buildings.
- Analysis of the spatial wind pattern.
- Calculation of the thermal comfort zoning with the corresponding thermal index.
- Evaluation through mobile measurements.

5.7 References

- [1] VDI (1998). *Guideline 3787/2. Environmental meteorology – Methods for the human-biometeorological evaluation of climate and air hygiene for urban and regional planning at regional level – Part I: climate*, Düsseldorf.
- [2] Katzschner, L., Bosch, U. and Röttgen, M. (2002). Behaviour of people in open spaces in dependency of thermal comfort conditions, *Design with the environment*, Proc.: 19th Passive and Low Energy Architecture (PLEA) International Conference, Toulouse, pp. 411-415.
- [3] Matzarakis, A. (2001). Die thermische Komponente des Stadtklimas, *Berichte des Meteorologischen Institutes der Universität Freiburg Nr. 6*, Freiburg.
- [4] Bauer, B. (1999). Mikrometeorologische Analyse und Bewertung kleinräumiger Platzstrukturen, *UFZ-Bericht 3/1999*, Stadtökologische Forschung, Nr. 18, Leipzig.
- [5] Teller, J. and Azar, S. (2001). TOWNSCOPE II - A computer system to support solar access decision-making, In *Solar Energy*, Vol. 70, No. 3, pp. 187-200.
- [6] Katzschner, L. (1997). Urban climate studies as tools for urban planning and architecture, *Anais IV*, ENCAC, Salvador.

6. VISUAL COMFORT IN URBAN SPACES

6.1 Introduction

In people's minds, a successful open space is often associated with a positive visual experience. Several factors can contribute to this satisfaction e.g.: unobstructed views towards the landscape or surrounding buildings, nice vegetation, spectacular façades, well designed urban furniture. All these factors are related to aesthetics and are therefore sources of "visual pleasure" ([1] provides a full chapter dealing with these issues).

Within the RUROS project, "visual comfort" has been addressed using a more technical approach borrowed from lighting design studies. To ensure "visual comfort", adequate illuminance levels, measured in lux, have to be provided throughout the space, while preventing glare sensations. More precisely, disability or discomfort glare occurs when the field of view contains either great luminance values, measured in cd.m^{-2} , or great luminance contrasts.

This approach that deliberately lets aside "visual pleasure" parameters is appropriate when studying open spaces in relation to their microclimate. "Visual comfort" is then a quality that results from an open space design that is well adapted to the daytime natural light resource, i.e. daylight, on the site. Night-time visual comfort provided by public lighting is not considered here, as it is already a well-documented topic.

Daylight penetration within the urban fabric has been recognized as an important quality factor that required means of preservation especially in very dense cities. As shown in [2], regulations dealing with urban zoning were often established for this purpose.

This chapter focuses on the microclimatic characteristics of the luminous environment measured at street level and the users' reactions observed simultaneously. The empirical relations presented hereafter between measurable parameters and users reactions or sensations were deduced from field surveys conducted in a dozen open spaces across Europe.

6.2 Illuminance levels and glare in urban open spaces

It is well admitted that for day-to-day visual tasks the required illuminance levels for comfortable visual perception range between 100-1000 klux, depending on the size of the geometrical details that have to be discriminated (higher illuminance levels for smaller details). As shown in Figure 6.1, daytime horizontal illuminance levels recorded in open spaces almost always exceed 1000 lux even in shaded locations. This allows any common visual task to be performed easily. Illuminance levels may become insufficient either at dawn or twilight, or in very dense areas with deep urban canyons.

Figure 6.2, shows four possible causes of glare in urban open spaces. For each picture, luminance values measured at some key points are listed in Table 6.1. These values are resulting from both the materials reflectances and the daylight illuminance from direct sunbeams and diffuse light coming from the sky, the ground and the surrounding buildings. The luminance contrasts observed in these supposedly glaring situations do not exceed 1:65, which is a rather low ratio compared to those as high as 1:4000, frequently encountered in daylight or artificially lit interiors. Of course, when the gaze is oriented close to the sun direction very large luminance ratios can be reached. However, this extreme case is not relevant since nobody is likely to maintain such a direction of looking for more than a few seconds.

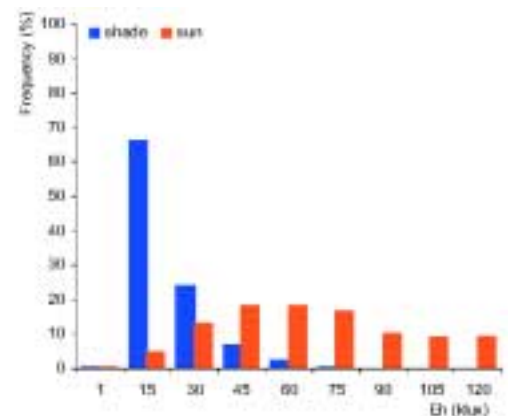

Figure 6.1: Daytime illuminance levels distributions observed in two open spaces located in Fribourg (CH). Measurements were taken for two weeks of each season. The horizontal axis is labeled according to the upper bounds of the illuminance level classes.

Similar distributions were observed in other European locations.



Figure 6.2: Possible causes of glare in urban open spaces (from top to bottom):
 - unusually clear façades
 - unusually dark façades
 - clear urban furniture
 - translucent canopy

Table 6.1.

Luminance values and contrast ratios measured on the four locations depicted on Figure 6.2.

	Luminance of key points (cd.m-2)	Max. Luminance contrast ratio
Unusually clear façade	Blue sky: 4000 Clear façade: 13000 Shaded pavement: 500	1:26
Unusually dark façade	Blue sky: 5000 Dark façade: 400 Clear façade: 8000 Shaded pavement: 700	1:20
Clear furniture	Shaded table: 2800 Sunlit table: 19000 Shaded pavement: 500	1:38
Translucent roof	Sunlit pavement: 2600 Shaded pavement: 800 Translucent roof: 52000	1:65

Since overcast skies act as a large light diffuser which smoothes out the luminances in the field of view (e.g. shadows disappear), the contrasts ratios under these circumstances could never exceed those observed under clear skies.

From these observations it appears that both illuminance levels and luminance contrasts prevailing in urban open spaces affect outdoor daytime visual comfort in a somehow different way than indoors. Hence, empirical relations between measurable parameters like illuminance levels and users' reactions have been established from field surveys. The following section presents these relations.

6.3 Users' appreciation of the luminous field

In order to assess people's appreciation of the visual field in open spaces, specific questions were asked in relation to:

- the luminous appearance of the space, defined as Luminous Sensation Vote (LSV), evaluated on a 5-point scale, varying from "very dark" to "very bright",
- the sunlight conditions, evaluated on a 3-point scale, varying from "too much sun" to "would prefer more sun" and
- glare of the surrounding surfaces.

Simultaneously, some observations were taken in order to study people's behaviour in relation to the luminous field.

Figure 6.3 shows the correlations observed between the horizontal illuminance, klux, measured at the same location where people were interviewed and the recorded answers or observations. Each point on the graphs was obtained by averaging the results of 30 interviews.

The first graph shows how people scale their brightness sensation. Surprisingly, even with very low illuminance levels, very few negative votes (dark side of the LSV scale) were recorded. Being outside seems enough for people to assess the brightness of the environment with $LSV \geq 0$. The regression curve regularly increases up to $LSV = +1$ (meaning "bright") for illuminance levels around 50 klux. LSV is also shifted up or down by the presence or absence of sunlight at user's location: for the same illuminance level, the LSV is increased by around +0.2 unit for a sunlit location compared to a shaded one. For higher levels that are typical of clear skies, the regression seems to rapidly

reach a constant maximum value around LSV=1.2. This denotes the very effective adaptation effect of the visual system. Although the mean LSV appear to follow a smooth curve, the individual votes are in fact largely dispersed. A majority of people rates the luminous field as “bright”. However, there are always 40% or more people voting something different. This is a clear sign that brightness perception varies significantly among people.

The second graph shows the preference of people for more (+1) or less (-1) sunlight. The trend appears very clearly, the less illuminance people get, the more sunlight they prefer. Surprisingly, this strong preference vanishes only for rather high illuminance values (~115 klux) that are reached only under sunny summer weather around noon.

From these findings, a simple empirical law seems to emerge, as users of open spaces always welcome more light, especially sunlight. However, the third graph shows that a rather great fraction of the people feels some kind of glare, even in shaded locations and under relatively low illuminance levels. Again the visual adaptation effect can explain the slow decrease of the regression curve above 70 klux. Figure 6.4 shows which parts of the field of view appear as glaring. Interestingly, the most frequent cause of glare appears to be the surrounding buildings façades. The sky or built canopies appears as the second cause of glare. Finally the ground or pavement also causes glare, but this occurs only under high illuminance levels that cannot be reached in shade.

The two following graphs show the frequencies of two observed reactions: wearing of sunglasses and movements to screen the eyes from excessive light, e.g. moving hands above the eyes, rotating or bending the head, blinking, etc. These behaviours can be considered as means of adaptation taken by people, consciously or not, in order to cope with the prevailing luminous field.

The last graph shows the fraction of people performing reading or writing tasks. Here no marked preference appears. This again illustrates the strong effect of visual adaptation that allows people to read or write in any type of outdoor luminous environment. This also indicates that outdoor visual comfort is probably more affected by the overall perceived luminous field than by the illuminance of the daylight visual task itself.

When comparing the correlations as presented in Figure 6.3 with those observed at other European locations some interesting similarities or differences appear:

- The LSV curves appear similar in shape from one site to another. They also never exceed a +1.2 LSV value. However, at low illuminance levels, the curve starts with lower LSV values for northern locations and conversely for southern locations.
- The sun preference regression shows a stronger wish for sun for northern latitudes while for southern latitudes the regression flattens very close to neutrality. This is due to the local climate that changes the relative frequency of clear or overcast skies, i.e. where overcast skies dominate the sun is far more preferable than where clear skies largely prevail.
- The fraction of people wearing sunglasses is the most varying parameter. In southern locations, at least 20% people wear sunglasses even under very low illuminance levels. Under high illuminance levels this fraction grows up to 60%. Conversely, in northern locations, this fraction never exceeds 15%–30%.

For design purposes, LSV values between 0.5 and 1 can be considered as appropriate targets. The first graph (Figure 6.3 top)

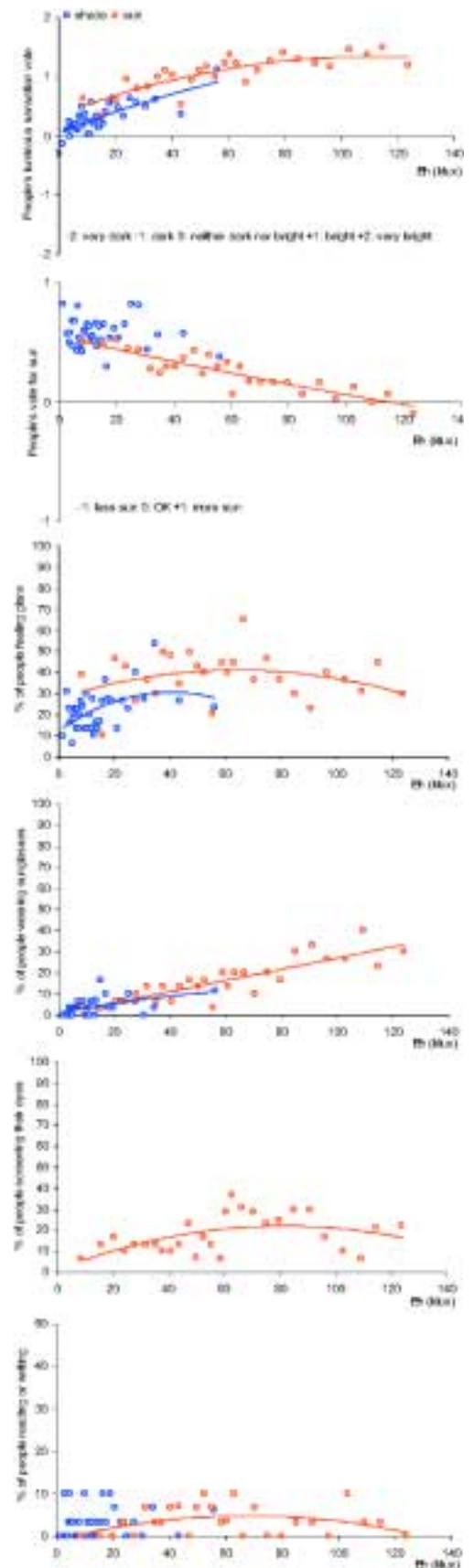

Figure 6.3: Empirical correlations observed in two open spaces located in Fribourg (CH). Horizontal illuminance levels (in klux) are shown on the horizontal axis (from top to bottom):
 - luminous Sensation mean Vote
 - sunlight preference
 - % of people feeling glare
 - % of people wearing sunglasses
 - % of people screening their eyes
 - % of people reading or writing



Figure 6.4: Surfaces claimed to appear as glaring versus horizontal illuminance.

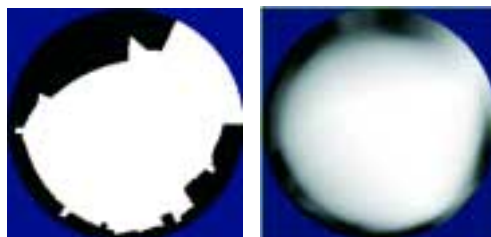

Figure 6.5: (Left) stereographic projection of the obstructions as seen for a single point within the open space shown on the above site plan (coloured in green)

(Right) multistereographic projection computed for the whole site. The grey level indicates the site area fraction that has open access to a given direction in the sky vault.



Figure 6.6: The multistereographic projection of the sky vault is split into three zones (black=sky directions obstructed on more than 80% of the site area, yellow=sky directions obstructed on less than 20% of the site area, white=criterion met). Finally, the sunpath diagram calculated for the latitude of the site is superimposed.

shows that LSV is kept within this range for horizontal illuminance levels from 10 to 50 klux in sunlight and from 25 to 60 klux in shade. When planning an open space, these ranges should be compared to illuminance levels prevailing at times when more people are expected to visit the site. As a rule of thumb, horizontal illuminance levels (in klux) can be estimated by dividing by 8 the incoming horizontal global solar radiation ($W.m^{-2}$). If the prevailing illuminance levels exceed 50 klux, some shading must be provided at least for some parts of the site.

6.4 Sunlight penetration and visual comfort

As shown in the previous chapter, sunlight is highly appreciated in open spaces. To help in the design, a tool for assessing sunlight penetration in open spaces is highly desirable. Sunpath diagrams superimposed on stereographic projections of surrounding obstructions are commonly used to evaluate solar access for single points [3]. However, for studying an open space as a whole, these projections do not provide much help since they differ considerably from one point to another.

A new method has been devised to overcome this problem. It is also based on a stereographic projection. However, instead of being calculated for a single point, it combines the projections calculated for sample points located on a regular grid that covers the whole area of interest. Hence the name “multistereographic” is given for this new projection. The multistereographic projection appears as a defocused view of the sky and the surrounding obstructions (Fig. 6.5). Each grey level pixel indicates the proportion of the area that has free access to its associated sky vault direction.

At this point a design requirement can be put forward. Visual comfort is better preserved when the field of view offers enough contrasts near the horizontal direction, where human activities are taking place. This requirement for variety in the visual field is also supported by others [1], [4]. Sunlight penetration at ground level is surely the main source of contrasts even varying with time. Therefore the design requirement can be translated as a criterion about the sunlit proportion of the open space, where the sunlit area should cover 20%–80% of the site. Using the multistereographic projection, it is then easy to identify the sky zone matching this criterion (Fig. 6.6). Finally, after superimposing the sunpath diagram, it is possible to visually assess, how well, and when the requirement is, or is not met.

As shown from the yellow zone of the multistereographic projection (Fig. 6.6), the buildings surrounding this square do not offer enough shade particularly in the summer from sunset until 4:30 pm (true solar time). In order to meet the requirement for at least 20% of shaded area, trees should be planted. The resulting effect could also be checked using a multistereographic projection.

In order to compute a multistereographic projection, a 3D digital model of the buildings surrounding the site has to be provided. The computation is then automatically performed using ray-tracing software. Such a tool will be provided as an Internet online service from June 2004 (www.eif.ch/ippf/).

6.5 Sky view from open spaces

By analysing where open space users look, it appears that the most frequent gaze direction is either oriented towards the most “open” part of the site (i.e. where the sky is less obstructed) or towards some specific activities, e.g. children playing. As shown in Figure 6.4 it also appears that surrounding buildings façades are often considered as glaring.

The relative visual effect of both the sky and the buildings façades can be estimated geometrically using the cylindrical illuminance concept (See Glossary). For instance, it is possible to identify the points where the sky occupies a larger part of the field of view than the surrounding buildings. On those points, “visual comfort” is expected to be enhanced and less sensitive to buildings façades colours or materials. This also means that on these points, visual comfort or discomfort conditions are under less control by the designers.

At design stage, it can then be useful to map for which parts of an open space the free view towards the sky dominates. Such parts can be considered as forming the “core” of an open space. The “core” part is very sensitive to the height of the surrounding buildings. For instance, as soon as the height-to-width ratio of an urban canyon exceeds $\sim 1:2$, its core part totally vanishes.

Figure 6.7 shows the “core” parts map for an existing square and the modification that may result after the construction of a new building on its southern side. The modified map allows for instance to ascertain that the visual comfort conditions prevailing at the playground area will not dramatically change once the projected buildings is built.

Again, these “core” parts maps can be automatically produced from a 3D digital model. This service will also be made available from June 2004 on the Internet (www.eif.ch/ippf/).

6.6 Checklist

Regarding the size of an open space:

- To perceive a building façade in its whole, users should see it at an angle less or equal to 27° above the eye-level plane [5]. This requirement is met for people standing at a distance greater or equal to twice the façade’s height.
- The maximal distance between users that allows face recognition is 24 meters.

Regarding illuminance level and sun penetration in open spaces:

- Except in very deep and narrow urban canyons or under arcades, daytime illuminance levels should always be sufficient.
- Sunlight should reach between 20% and 80% of the site area at all times. Real or virtual heliodons may be used to ensure this criterion is met. However, the mutistereographic projection presented in this chapter is an even more convenient tool for this purpose.

Regarding preferential direction of looking in open spaces:

- Areas of intense activity as well as the “core” part of the site are always more attractive than the rest of the site. In order to ensure that a “core” part can exist, the height-to-width ratio measured between the surrounding façades and the width of the space should be kept under $\sim 1:2$. For complex geometries, the “core” part should be calculated from a 3D digital model of the site.

6.7 References

- [1] Carmona, M. et al. (2003). *Public Places – Urban Spaces*, Architectural Press.
- [2] Bryan, H. and Stuebing, S. (1986). Natural light as an urban amenity, *Lighting Design and Application*, Vol. 16, June.
- [3] Littlefair, P.J. et al. (2000). *Environmental Site Layout Planning: Solar Access, Microclimate and Passive Cooling in Urban Areas*, Building Research Establishment, London.
- [4] Lozano, E.E. (1974). Visual needs in the urban environment, *Town Planning Review*, Vol 45, No.4.
- [5] Ashihara, Y. (1970). *Exterior design in architecture*, Van Nostrand Reinhold Company.

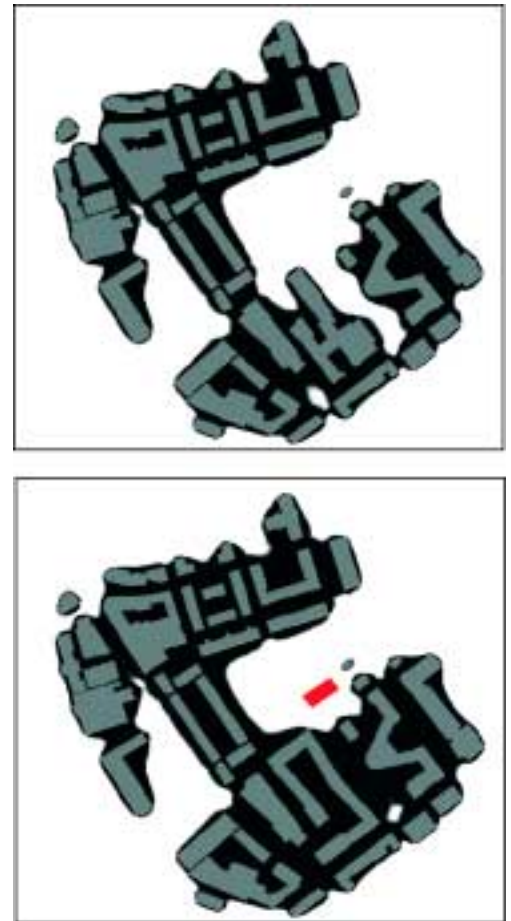

Figure 6.7: Maps highlighting the “core” parts of this square (top: existing site, bottom: after the construction of a new projected building on its southern side).
White = point within the “core”.
Black = point outside the “core”.
The playground location is shown as a red area.

7. SOUND ENVIRONMENT AND ACOUSTIC COMFORT IN URBAN SPACES

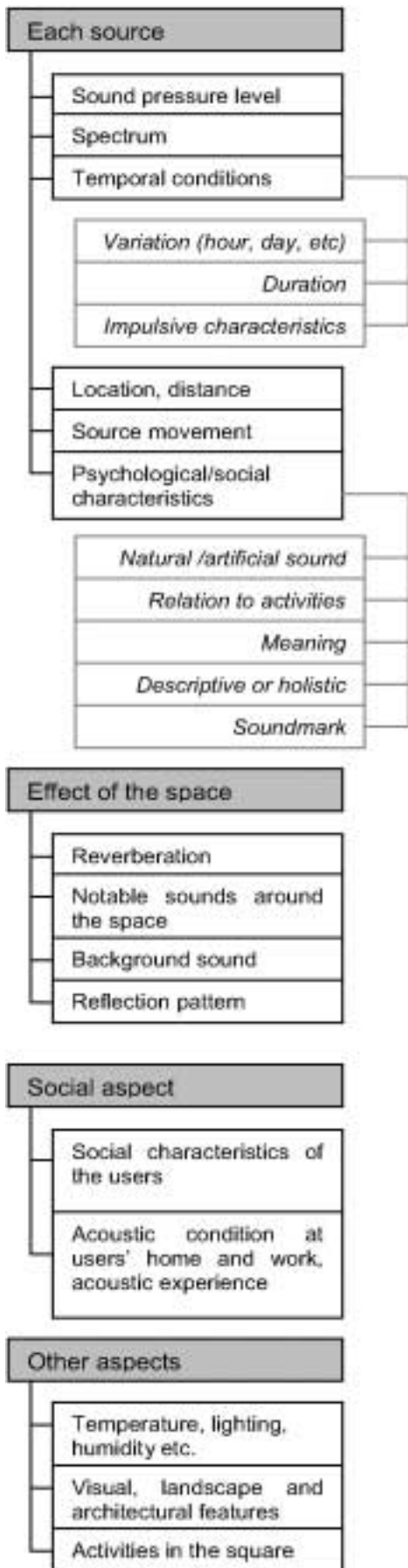

Figure 7.1: Framework for Describing Soundscape in Urban Open Public Spaces.

7.1 Introduction

Sound environment is an essential aspect of the physical comfort of urban open public spaces. This is systematically discussed in this chapter. The chapter starts with a system for describing soundscape of urban open public spaces. It then discusses people’s acoustic perception based on the survey across Europe. This is followed by a series of design tools/considerations suitable for various levels of users. Finally relevant legislation, references, and a checklist are given.

7.2 Soundscape description

To design a good acoustic environment in an urban open public space, not only physical aspect, but also social, psychological, and physiological aspects should be considered. Soundscape and acoustic comfort study focus on relationships between ear, human being, sound environment and society. It is also important to consider the interaction between sonic environment and microclimate conditions, as described in other chapters of this booklet.

A model for describing the soundscape in urban open public spaces is shown in Figure 7.1. The description includes four parts, namely characteristics of each sound source, acoustic effect of the space, social aspect, and other aspects. Since in different locations of an urban open public space the soundscape could be rather different, the description should be based on a number of typical receivers.

Sounds in an urban open public space can be defined as keynotes, signals/foreground sounds and soundmarks [1]. Keynotes are in analogy to music where a keynote identifies the fundamental tonality of a composition around which the music modulates. Foreground sounds, also termed ‘signals’, are intended to attract attention. Sounds that are particularly regarded by a community and its visitors are called «soundmarks», in analogy to landmarks.

For each sound source, the sound pressure level (SPL), spectrum, temporal conditions, source location and the distance from the users, source movement, and the psychological and social characteristics should be considered. For the sound level, both steady-state and statistical SPL [2] should be considered. It is measured in dBA, a weighting system corresponding to human beings feeling towards sounds. For the spectrum, if tonal component is noted, it might be useful to consider narrowband spectrum [2].

The acoustic effect from an urban open public space is important. Boundaries and landscape elements may cause reverberation in an urban open space, which affects the acoustic comfort. Reverberation can be expressed using decay curves or reverberation time (RT). Reverberation time is defined as the time taken for a sound to decay 60dB after the cut-off of the source. The RT is usually obtained from -5dB to -35dB on a decay curve [2]. The EDT, which is highly correlated with speech intelligibility, is based on the decay from 0 to -10dB. In both cases the slope is extrapolated to correspond to 60dB decay [2-3]. In addition to reverberation, reflection pattern and/or echogram should be checked for possible acoustic defects like echoes and focus effect [2-3]. It is also useful to know the general background noise and special sound sources around the urban open space

investigated/designed as well as in the whole city. It has been shown that the surrounding acoustic environment may affect subjective evaluation of an urban open space.

Social aspects of the users also play an important role and thus relevant information should be obtained. This includes gender, age group, place of living (i.e. local resident or from other cities), previous acoustic experience, the acoustic environment at home and working places, as well as general cultural and education background [4-6].

The interaction between acoustic comfort and other factors like thermal and visual comfort also needs to be taken into account. For example, the effects of visual images reduce the negative impression of sound quality and the amount is sometimes equivalent to a 10dB reduction in SPL.

7.3 Soundscape perception

7.3.1 Sound Level

The Leq (equivalent continuous noise level) over a time period has been widely adopted as a general purpose index for environmental noise [2]. For urban open public spaces, however, the background sound level, say Leq90, namely the 90 percentile-exceeded sound level [2], is another essential index [5]. A low Leq90 can make people feel quieter, even the foreground sounds reach a rather high level.

Generally, the subjective evaluation of the sound level relates well with the mean Leq, especially when the Leq is lower than a certain value, say 73dBA. However, the acoustic comfort is not necessarily correlated to the subjective sound level because of the psychological adaptation in perceiving soundscape. The content of a sound, for example, whether it is meaningful or meaningless, is very important in the evaluation process. Figure 7.2 shows a relationship between measured sound level, subjective sound level, and the evaluation of acoustic comfort.

Moreover, people from a noisy home environment tend to adapt more to noisy urban open public spaces [5].

7.3.2 Sound Preference

Preference of sounds appears to depend on much more factors than the sound level. Differences in sound preferences are in three levels [5]. The first level is the essential preference. People generally share a common opinion in preferring natural and culture-related sounds rather than artificial sounds. Vehicle sounds and construction sounds are regarded as the most unpopular, whereas those from human activities are normally rated as neutral. Second, cultural background and long-term environmental experience play an important role in people's judgment of sound preference. People from a similar environment may show a similar tendency on their sound preferences, which can be defined as macro-preference. Third, personal differences, such as gender and age, further influence people's sound preference, which can be defined as micro-preference.

Young and older people may have some essential differences in evaluating sounds. For example, with the increase of age, people are generally more favourable to, or tolerant, sounds relating to nature, culture or human activities. By contrast, young people are more favourable to or tolerant sounds like street music and mechanical sounds. Figure 7.3 shows some differences in sound preference between age groups.

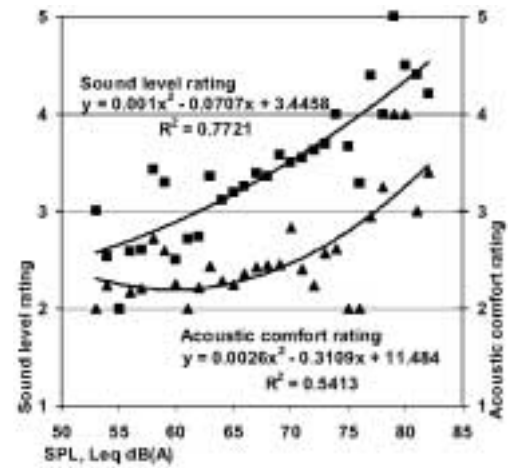

Figure 7.2: Relationship between Sound Level, Sound Level Rating and Acoustic Comfort Rating in the Peace Gardens, Sheffield.

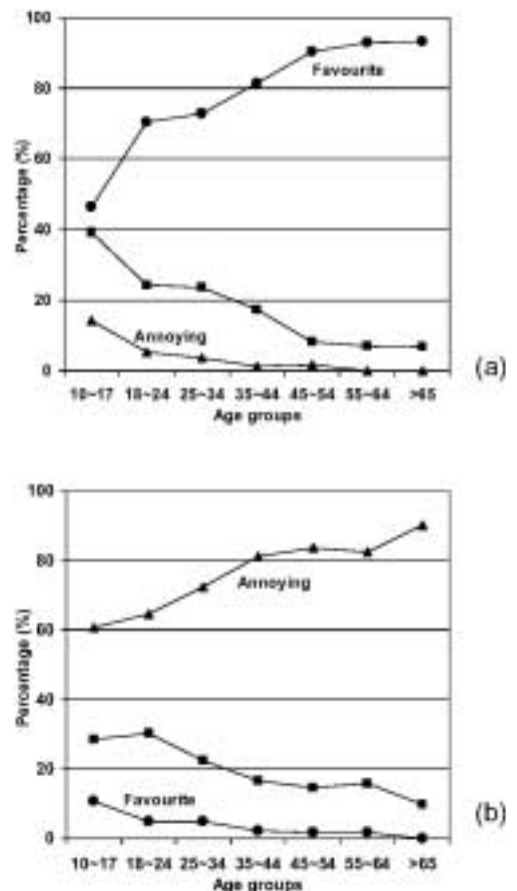

Figure 7.3: Sound Preference Differences between Age Groups. (a). Bird songs; (b). Music from Car.

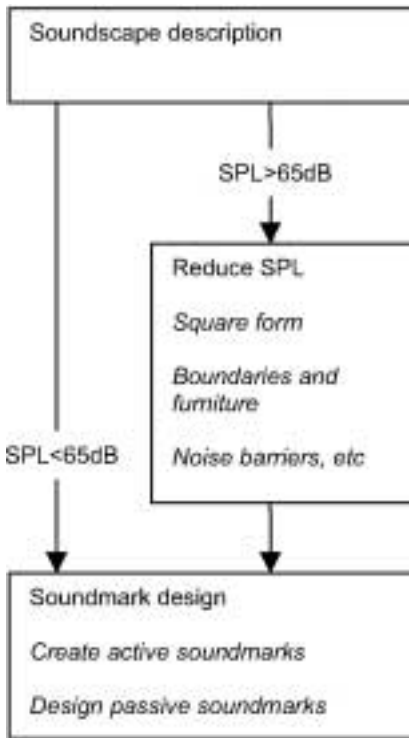

Figure 7.4: Soundscape Design Process.

Between male and female there are only slight differences. The sound preference of females tend to be influenced by emotion. They may be more favourite to or tolerant sounds like bells of church, water, music played on street, bells or music from clock and children's shouting.

7.3.3 Factors for Acoustic Evaluation

It is important to identify some factors for soundscape evaluation. A semantic differential analysis has demonstrated that these factors include relaxation (comfort-discomfort, quiet-noisy, pleasant-unpleasant, natural-artificial, like-dislike and gentle-harsh), communication (social-unsocial, meaningful-meaningless, calming-agitating and rough-smooth), spatiality (varied-simple, echoed-deadly and far-close), and dynamics (fast-slow and hard-soft).

For evaluating the soundscape in an open urban public space, a sample size of about 150 is typically acceptable.

7.4 Soundscape design

7.4.1 Reduce Background Sound Level

A framework for soundscape design is shown in Figure 7.4. To create a good acoustic environment, it is advisable to reduce the background sound level to a certain level, generally 65dBA [4-9].

Noise reduction can be considered in three aspects: source, sound path and receiver [2]. In a free field, each doubling of the distance means a SPL drop of 6dB for a point source and a 3dB for a line source. Noise barriers can be introduced to reduce the sound level [2].

7.4.2 Computer Models

To predict sound propagation in urban squares, two computer models have been developed at the University of Sheffield, one based on the radiosity method, and the other on the image source method [7-9]. The former is for diffusely reflecting boundaries (i.e. acoustically rough) whereas the latter is for geometrically reflecting boundaries (i.e. acoustically smooth). The models have been validated by measurements [3].

Noise mapping software like CADNA [10] and some room acoustics based software like Raynoise [11] can also used to analyse the soundscape in urban open public spaces.

7.4.3 Formulae

In urban squares with diffuse boundaries the reverberation time can be calculated by [8]

$$RT_{30} = \frac{0.16V}{-S \ln(1 - \bar{\alpha}) + 4mV} (88.6 + 49\alpha_b + 2.7 \frac{\sqrt{LW}}{H})$$

where L is the square length, W is the square width, H is the square height, S is the total surface area and $\bar{\alpha}$ is the average absorption coefficient, both including an imaginary square ceiling. $V=LWH$, m , is the air absorption factor, α_b and is the average absorption coefficient of boundaries, i.e. façades and ground only.

The sound distribution with a point source can be calculated by

$$L = L_w + 10 \log \left(\frac{Q}{4\pi r^2} + \frac{3H}{W + L} \frac{4}{R} \right)$$

where and $R = S\bar{\alpha}_r / (1 - \alpha_r)$ and $\alpha_r = \bar{\alpha} + 4mV/S$. L_w is the sound power level of the source, Q is the directivity factor of the source, and r is the source-receiver distance.

7.4.4 Square Form

Effects of architectural changes and urban design options on the sound field of urban squares have been studied using computer models developed at the University of Sheffield [7-9]. Typical results are summarised below, considering square size, building height and aspect ratio, as well as boundary absorption:

- (1) When the square side is doubled the SPL is typically 6-9dB lower in the far field, as shown in Figure 7.5a.
- (2) With a greater aspect ratio, the difference between diffuse and geometrical boundaries becomes greater, and the SPL attenuation is considerably greater in the far field, especially for diffuse boundaries, as shown in Figure 7.5b.
- (3) Between building heights 6m and 50m, with diffuse boundaries, the SPL difference is typically 8dB, as shown in Figure 7.5c.

7.4.5 Square Boundary and Furniture

With the increase of boundary absorption coefficient, the SPL reduces proportionally, and the reduction is typically 12dB when the absorption coefficient is increased from 0.1 to 0.9, as shown in Figure 7.6.

In urban squares with diffusely reflecting boundaries the reverberation is much shorter and the sound attenuation is greater than in those with geometrically reflecting boundaries, unless the height/side ratio is large, say around 1:1. Even for façades and ground where only about 20% of the energy incident upon the boundaries is diffusely reflected, the sound field in an urban square is close to that resulting from purely diffusely reflecting boundaries [9]. This means that the effect of adding even a small amount of diffusion to an urban square, where the reflections are mainly specular, can be very beneficial from the viewpoint of urban noise reduction. Similar to diffuse boundaries, street furniture, such as lampposts, fences, barriers, benches, telephone boxes, and bus shelters, can also be effective in reducing noise [12]. Figure 7.7 compares the two kinds of boundary in terms of SPL and reverberation.

Vegetation on building façades and the ground can increase boundary diffusion of incident sound and also increase boundary absorption thus reducing noise further. The efficacy of vegetation will be greater in urban squares than in an open field due to the multiple reflections. Similarly, the effect of trees in urban squares will be to introduce additional absorption and scattering.

7.4.6 Soundmarks

When the SPL is reduced to around 65dBA the soundscape quality may be further improved by introducing more favourite sounds. Both active soundmarks and passive soundmarks can be considered.

The 'active soundmarks' relate to the sounds generated by interesting activities, which may add dramatic elements to a soundscape. It is important to provide specified locations for such activities/occasions and consider acoustic design of the space. Live music is always very popular. People are not only interested in the music itself, but are also attracted by the activities of the players. In this case, the type of music (e.g. classic music and pop music) is not a very important issue. However, when music is played using loudspeakers, the type of music as well as the sound level need to be considered carefully. Most people don't like loud music played from loudspeakers, whatever the music type is.

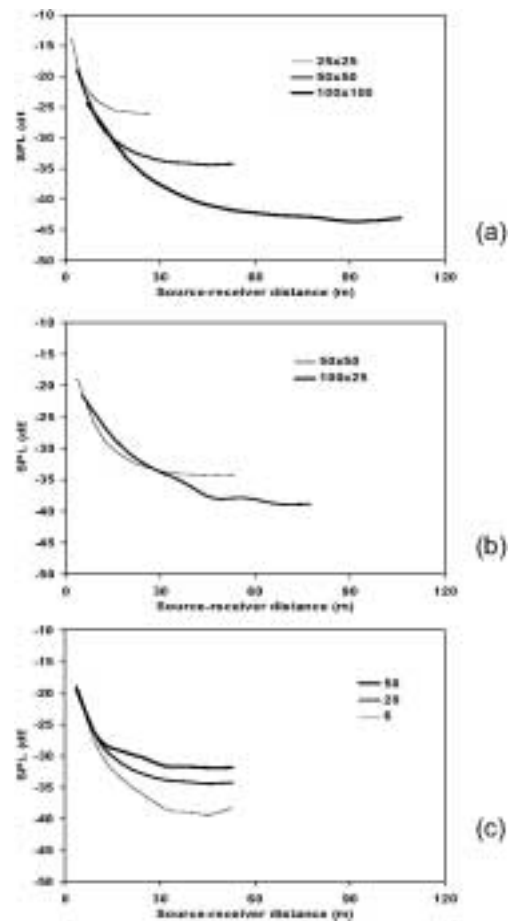

Figure 7.5: Effect of Square Size, Aspect Ratio and Height. The Basic Square Configuration is 50x50m, 20m High, and Absorption Coefficient 0.1.

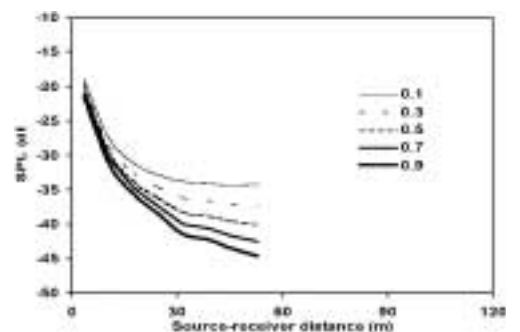

Figure 7.6: Effect of Boundary Absorption Coefficient.

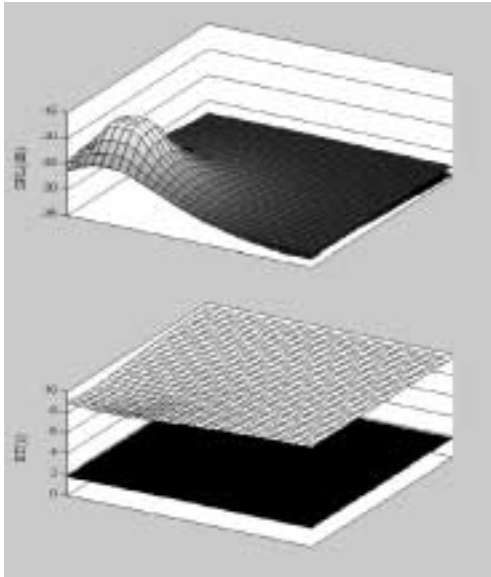

Figure 7.7: Comparison Between Diffuse (black) and Geometrical (grey) Boundaries.

To introduce ‘passive soundmarks’, many kinds of design features with favourite sounds can be applied, both for functional and aesthetical purposes. Water, in the form of fountains, springs or cascades, is often used as a landscape element in urban open public spaces. The sounds of water are attractive to most people, but particular attention must be paid to the water flow rate. It is suggested that the flow rate of a water feature should not be constant. Keeping it at the same sound level range may make people lose interest and the effect on their psychological adaptation may diminish with time.

7.5 List of relevant legislation

EU Green Paper on Future Noise Policy, 1996.

<http://europa.eu.int/en/record/green/gp9611/noise.htm>

EU Environmental Noise Directive 2002/49/EC, 2002.

<http://www.eeb.org/activities/noise/main.htm>

ISO 1996, Acoustics: Description and measurement of environmental noise.

WHO: Guidelines for Community Noise, 1999.

<http://www.who.int/peh/noise/guidelines2.html>

PPG24 Planning Policy Guidance Note 24, 1994.

<http://www.planning.detr.gov.uk/ppg/ppg24/pdf/ppg24.pdf>

7.6 Checklist

- Sound sources and their physical/social/psychological/cultural characteristics
- Effects of the surrounding buildings and square furniture on the acoustic environment
- Characteristics of users and their sound preferences
- Relevant legislations
- Relationships between acoustics and other aspects

7.7 References

- [1] Schafer, M.R. (1976). *The Turning of the World*. McClelland and Stewart, Toronto.
- [2] Egan, M.D. (1988). *Architectural Acoustics*. McGraw-Hill, Inc., New York.
- [3] Kang, J. (2002) *Acoustics of Long Spaces: Theory and Design Guide*. Thomas Telford Publishing, London.
- [4] Yang, W. & Kang, J. (2001). Soundscape design in urban open public spaces. *Proceedings of the 17th International Conference on Acoustics (ICA 2001)*, Rome.
- [5] Yang, W. & Kang, J. (2003). A cross-cultural study of soundscape in urban open public spaces. *Proceedings of Tenth International Congress on Sound and Vibration*, Stockholm.
- [6] Kang, J. & Zhang, M. (2002). Semantic differential analysis on the soundscape of open urban public spaces. *The Journal of Acoustical Society of America*, 112, 2435.
- [7] Kang, J. & Zhang M. (2003). Acoustic simulation and soundscape in urban squares. *Proceedings of the 10th International Congress on Sound and Vibration*, Stockholm.
- [8] Kang, J., Meng Y. & Brown G. (2003). Sound propagation in micro-scale urban areas: simulation and animation. *Acustica/acta acustica*, 89, S68-69.
- [9] Kang, J. (2002). Computer simulation of the sound fields in urban squares: comparison between diffusely and geometrically reflecting boundaries. *Proceedings of the 32nd International Acoustical Conference (IAC)*, Slovakia.
- [10] Datakustik (2003). *CadnaA: Software Program for Noise Prediction*, Munich.
- [11] LMS Numerical Technologies (2003). *Raynoise Users' Manual*. Leuven.
- [12] Kang, J. (2000). Sound propagation in street canyons: Comparison between diffusely and geometrically reflecting boundaries. *The Journal of Acoustical Society of America*, 107, 1394-1404.

8. DESIGN PRINCIPLES AND APPLICATIONS

The rehabilitation of an existing open space or the design of a new one can ensure the opportunity for the improvement of the comfort conditions outdoors. The possible solutions to the specific problems such a site faces are unlimited, depending on local morphology, climate and the aesthetic nature of the design proposal. Regardless of the variety of the solutions, there are some considerations that the designer has to take into account in order to succeed in providing an attractive and comfortable environment.

The first issue that arises in the design process is the profile of the seasonal use of the open space. With the exception of acoustic comfort, which is not affected by the season of the year, visual and mostly thermal comfort, require different actions in order to successfully provide a mild and pleasant environment, compared to ambient conditions.

Regarding the summer period, temperature control is essential for the achievement of comfort. Especially in southern latitudes, shading is the most important factor for temperature control and a significant parameter of visual comfort. A variety of shading devices or vegetation types can be used, according to the desirable shadow pattern. Vertical or sloped shading devices like walls, panels or bushes are preferable to placed on the western side of the site, taking into account potential restrictions such a device may cause in open space's ventilation (Figure 8.1). A similar shadow pattern can be achieved by trees with the advantage of air cooling or solar exposure in winter (Figure 8.2). Horizontal devices, including pergolas, can provide shadow for more hours a day and are useful in shading walking paths or long shaped areas like pedestrian zones (Figure 8.3). Still, they have to be constructed in a way to avoid hot air enclosure underside.

Wind channelling in the summer is significant for heat extraction from the open space. Vertical panels or vegetation can be used, in order to redirect the air in specific areas of the open space. Furthermore, water surfaces in the form of water films, waterfalls, ponds or fountains can contribute to air cooling in combination with the ventilation strategies.

Surface materials are an important factor, which affects both the thermal and the visual environment. Light colours and reflective surfaces can prevent surface overheating, but may cause glare and thermal reflection for users and on the surrounding surfaces or buildings. In contrast, dark surfaces can become overheated, but only when they are exposed to solar irradiation. Most vegetation surface covers not only prevent reflections but contribute to air cooling by evapotranspiration.

In winter, the main purpose of the design process is to protect the open space from cold wind and rain and to allow for solar exposure. An interesting example is the sunken open spaces (Figure 8.4). In combination with other measures they can be very effective in wind protection letting the wind passing above them. Deciduous trees permit solar exposure but evergreen act as efficient wind breaks (Figure 8.5). The social implications of such a solution, however, will have to be carefully considered.

Concerning noise reduction, vegetation can be considered for sound barriers, while also used for shading or wind breaks. Sunken open spaces are also effective in noise reduction.

In summary, there are no straightforward measures since every action affects other comfort parameters. The design proposal has to have an integrated form taking into account all the parameters of comfort and the specific morphological and climatic characteristics of the site.

The following sections present a variety of design solutions for different open spaces studied in detail, in Greece.

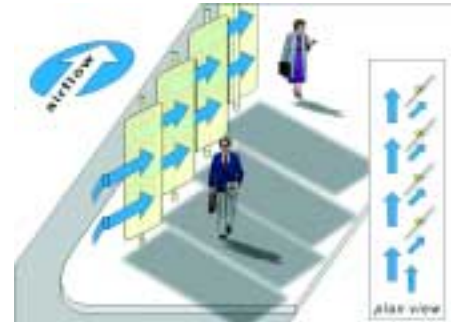

Figure 8.1: Panels can be used for shading and wind channelling during summer or for air blocking in winter.



Figure 8.2: Deciduous trees offer shading in summer and if properly selected, can enhance air cooling by evapotranspiration. In winter they permit solar exposure of the site.



Figure 8.3: Galleries along a pedestrian zone can provide shading and protection from rain.



Figure 8.4: "Sunken" open spaces are an interesting solution to noise and wind protection. Tall shading devices can be easily used without interrupting the view beyond.



Figure 8.5: Dense canopy trees can act as wind breaks when they are placed at the prevailing wind direction in winter.

8.1 Case Studies

8.1.1 Kritis Square

The site is a representative urban open space in a densely built residential area, at the city of Thessaloniki. There is limited commercial activity, traffic at the roads around the site is light and consequently, there are no significant noise sources. In general, the square attracts many people due to the dense vegetation surfaces. Only the use of the amphitheatre is limited due to its solar exposure, where overheating problems and glare from the light surface materials are the main reasons for local discomfort in the summer.

The design proposal (Figure 8.6) concerns mainly this section of the site since the rest of the area already provides an attractive microclimate with proper shading from the trees and the bushes as well as visual comfort. Only some pavement modifications in order to give access to more areas of the site are needed. The most significant intervention, at the northwest section of the site, concerns the construction of a large water surface. A kiosk provides a comfortable,

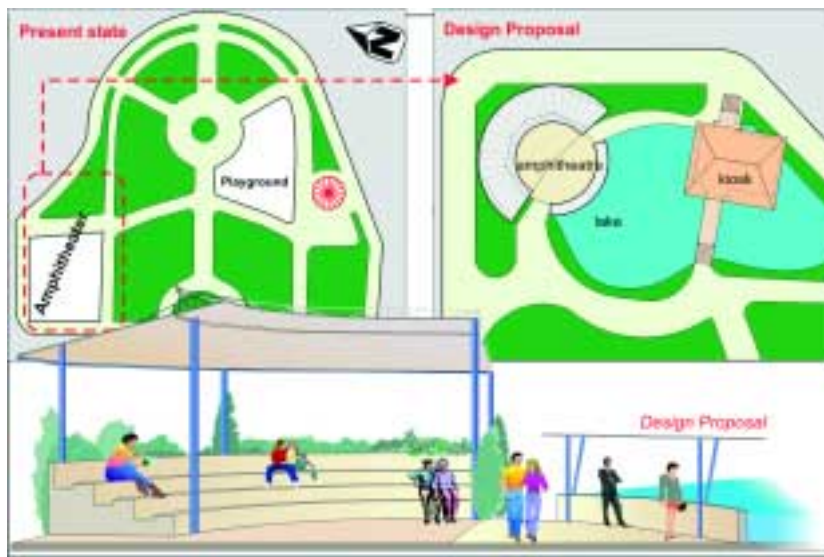

Figure 8.6: Present state and design proposal for Kritis square. In more detail the cross section of the amphitheatre.



Figure 8.7: Design proposal for the site of Makedonomahon square and details of some of the proposed constructions.

shaded area for rest and recreation. Several modifications are proposed concerning the form and the shading of the amphitheatre in order to make it more attractive to the users.

8.1.2 Makedonomahon Square

The site is located at the center of Thessaloniki, on the junction of two of the main streets, resulting in heavy traffic and noise. Other significant problems are the high air and surface temperatures in summer, glare from ground surface and building façades.

The site is used mainly during the summer and the transient seasons of the year. Despite the presence of the relatively tall surrounding buildings at the three sides of the square, solar exposure is the most important factor for discomfort.

The most efficient shading protection, besides the existing trees, can be achieved by horizontal shading devices like pergolas. At the top of the pergolas, vines can be planted that will contribute to shading during the summer period and allow solar exposure in winter (Figure 8.7). Their contribution to visual comfort is also important by decreasing glare from the sky, the building façades and the ground surface cover.

Water surfaces in the form of a fountain, a small stream and a waterfall can contribute further to microclimate improvement by air cooling.

The noise reduction can be achieved by the construction of a sound barrier at the side of the high traffic street, where the noise source is located. The sound barrier is thicker than the required one, because it is designed in such a way to house the watering mechanical equipment for the waterfall and the soil needed for the vines that cover both of its surfaces. An overhang at the internal side provides shading for people that cross the open space. The existence of the waterfall beyond its cooling purposes, contributes to a more pleasant acoustic environment by masking the traffic noise.

8.2 Pilot Applications

8.2.1 Karaoli & Dimitriou Street, Municipality of Themi, Greece

The site, Karaoli & Dimitriou Street is located in the centre of the municipality of Themi in northern Greece. It is close to the main traffic node and its long axis lies at an angle of 20° with W-E orientation. Most of the adjacent buildings are two-storey ones, the average width is 14m and the total length of the street to be renovated is about 370m.

The design process has to comply with several restrictions that do not exist in the case of parks and squares, as the issue at hand is the change of use of a street with vehicular traffic to a pedestrian zone. In this case, a number of parameters complicate the solution to this problem and determine whether conventional or unconventional solutions ought to be adopted.

The most important restrictions are the need to provide adequate access routes, where vehicles can supply the shops with goods at specific times of the day, usually early in the morning, and the limited width of the open space. In addition, the possible existence of parking spaces among the adjacent buildings and the possibility of future ownership of the existing buildings or construction of new ones are issues that cannot be ignored by the designer and play an important role in the design concept.



Figure 8.8: Physical model of the design proposal.

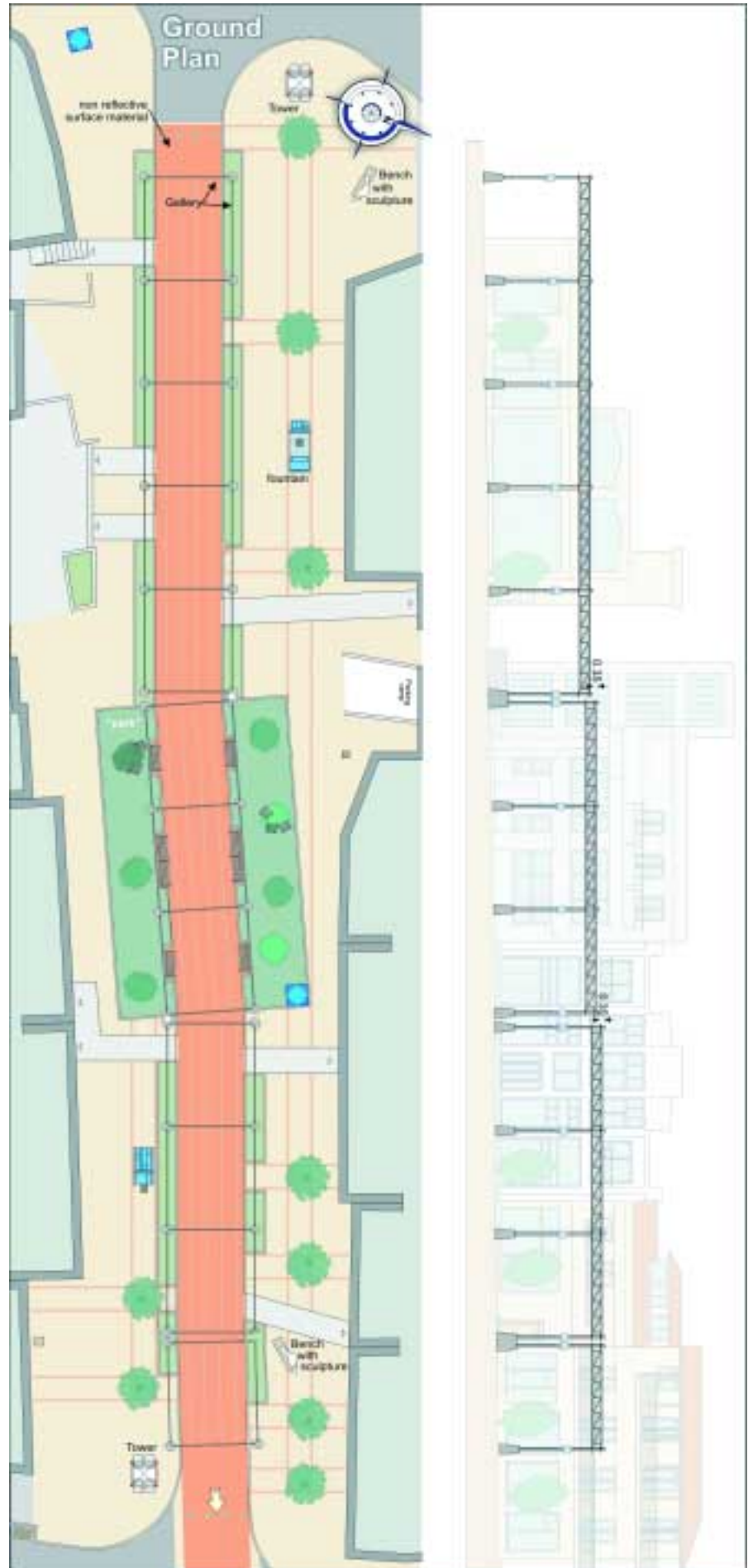

Figure 8.9: Plan view and cross section of the design proposal (part of the street).

Finally, among these problems, the geometry and position of the adjacent buildings should be included. In many cases their existence can affect the aesthetics of such a project. An integrated proposal should include the renovation of their façades, even under bioclimatic criteria. Unfortunately, such an integrated application is considered to be difficult and time-consuming due to the complex actions required in order to impose renovations on private properties.

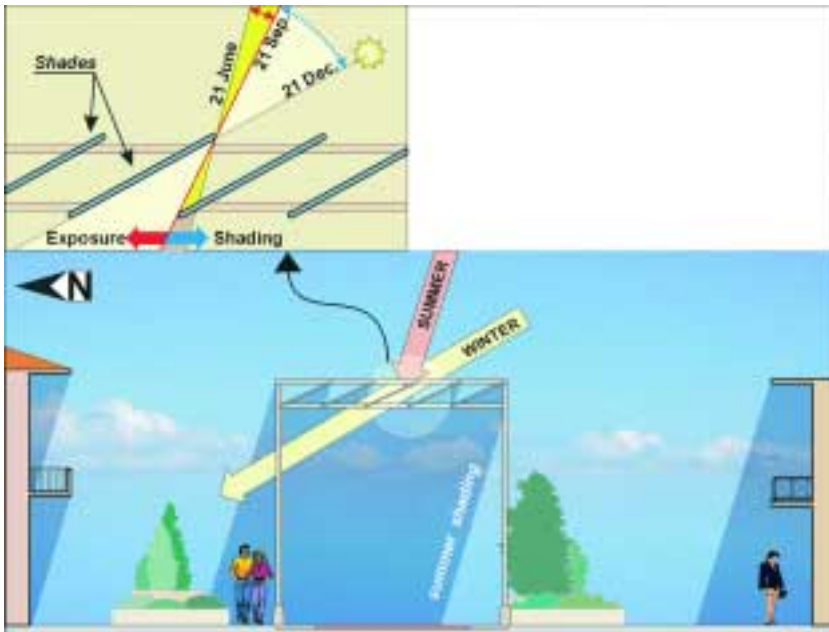

Figure 8.10: Cross section of the proposal.

The main characteristics of the design proposal are:

- A single gallery located in the middle of the pedestrian zone composed of identical cubic elements, measuring 6 x 6 x 6m, is a major feature of the concept, housing principally a path for pedestrians and secondarily a low-vehicle traffic surface (Figures 8.8-8.9). The floor, made of red asphalt material, has a width of 4m (less than that of the gallery in order to limit the traffic). The roof includes a shading device with shades facing south, spaced at regular intervals, in order to allow free airflow and prevent overheating. The slope of the shades permits solar exposure in winter and provides full shading in summer (Figure 8.10).
- The issue of the shades' material is another difficulty of the design process. The need for adequate illumination levels, easy maintenance, strength to resist wind pressure and other environmental effects led to the selection of polycarbonic leaves with reflective coating on the upper side, in order to avoid overheating.
- The pedestrians' path is interrupted at regular intervals by small squares covered with coloured block elements that enter the gallery in order to break the continuity of the road (Figure 8.8). Within these squares resting places, water features low vegetation and trees exists to enhance natural cooling. It is proposed for all these features to be designed by various well-known artists, so that the site may become a gallery with sculptures and after various supplementary measures, part of the "map of art villages".
- The sound barrier at the north-east entrance to the site is expected to decrease the noise levels caused by the relatively high volume of traffic in the adjacent centre of the municipality. After being appropriately and efficiently sized, a sculpture will give the barrier its final shape. It will consist of glass and moving water and it will be illuminated accordingly.



Figure 8.11: Initial proposal.

Prior to the final solution presented here, two other design solutions were proposed. These were presented to the Municipality community to promote a discussion with the citizens, in order to discover their opinion and other specific needs.

The initial concept focused on the creation of side galleries in contact with the building façades on both sides of the pedestrian zone. This decision covered two main requirements:

- The building façades are not aligned. This results in an irregularity since some buildings lie above the side axis and some below. The side galleries with varying widths could partially overcome this problem.
- Additionally, the galleries would provide shading and protection against wind and rain, offering a more comfortable and pleasant area that could lead to the presence of citizens all year round.
- In the middle of the pedestrian zone, the proposal included installations with water films, low vegetation and trees, relatively small sunken spaces that would guide pedestrians and offer an interesting attraction for resting and socializing. The proposal had to be accepted by all the building owners, since the side galleries would lie on their properties. Under the current legislation it was not possible to apply this proposal without the permission of the owners, who viewed it rather skeptically. The importance of this public debate led to a second, alternative solution, which was also not adopted.

8.2.2 3rd September Square, Municipality of Alimos, Greece

The site is located at the Municipality of Alimos, near Athens, in a residential area with three to five-storey buildings. It is of a triangular shape with its long dimension oriented to the east with a total area of 520m². On the area there is currently a playground, small vegetated surfaces and medium size trees.

The main microclimatic problems in the summer are solar exposure and high air temperatures and in winter, the direct exposure to the prevailing cold wind. No significant noise sources are present due the low traffic and the residential character of the surrounding area. Another critical design factor is the limited available area (240m² without the external sidewalks).

Other significant factors that strongly affect the design proposal are the need for safety (children supervision, visual contact with the surrounding area) and the connection of the square with the future pedestrian zone to the east side of the square.

The main characteristic of the design proposal (Figures 8.12-8.14) is the construction of galleries that host shaded walking paths. At the sides of these paths, benches and flowers give the opportunity for rest in a pleasant environment.

The shades at the top of the galleries are made of perforated aluminum and their dimensions and slope are calculated in such a way, to maximize solar gains in winter and shading in the summer (Figure 8.12). Shading covers most of the

surface below the galleries and a part of the adjacent area - depending on the season of the year and the time of the day - and protects users from solar irradiation, creating a pleasant environment.

Low vegetation areas around the open space create a natural environment, protecting at the same time the playing of the children. The lower level of the tree canopy is above average people's height, in order to permit direct visual contact with the surrounding environment.

Ground surface consists of solid blocks in various colours according to the main use of each area. Two water surfaces (water films) contribute to cooling of the air and together with the shading, vegetation and appropriate surface colours, create a pleasant environment.

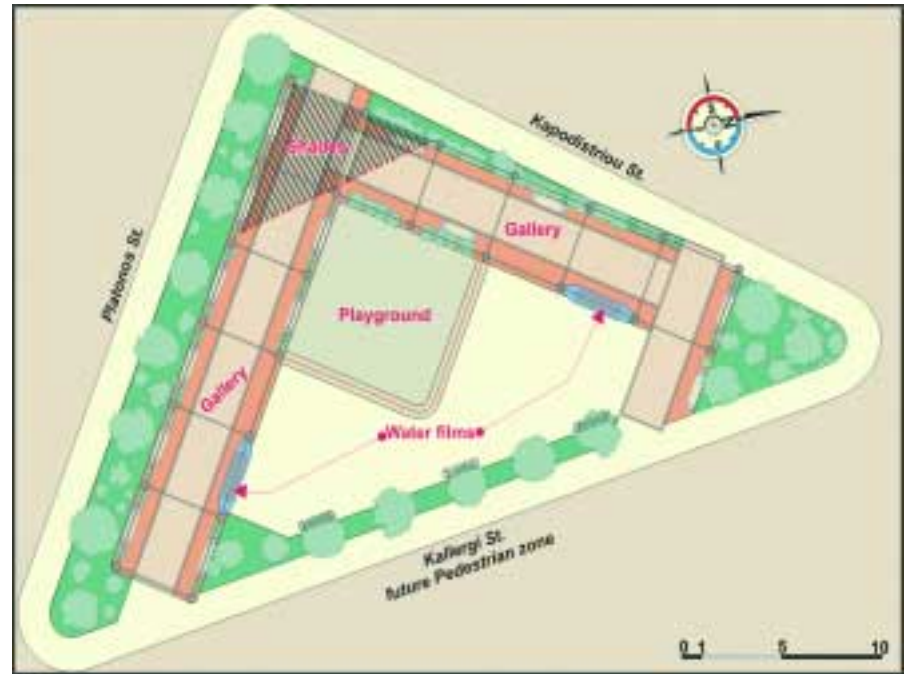

Figure 8.13: Plan view of the design proposal.

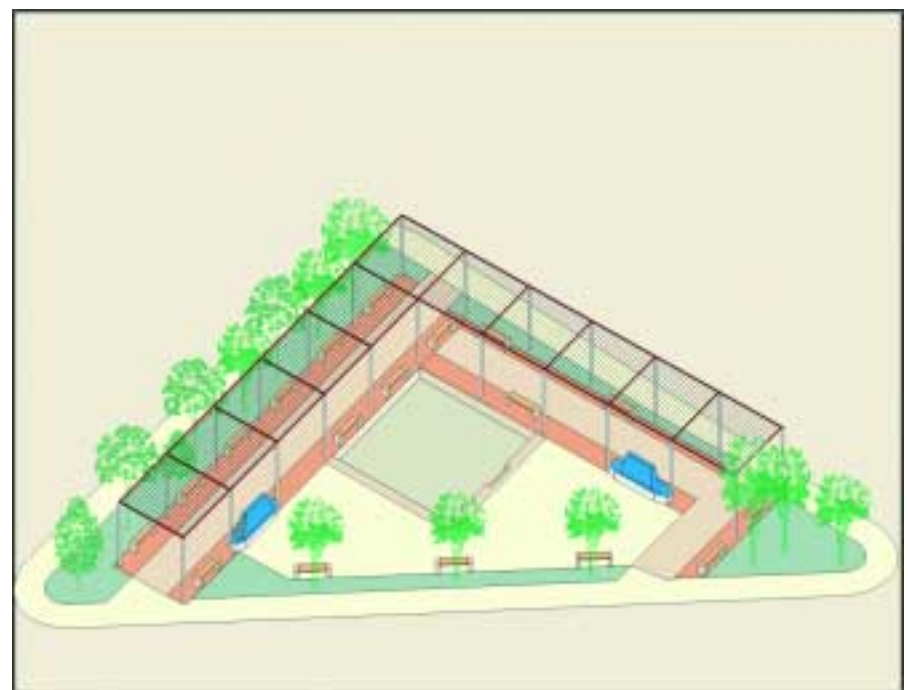

Figure 8.14: Perspective view of the design proposal.

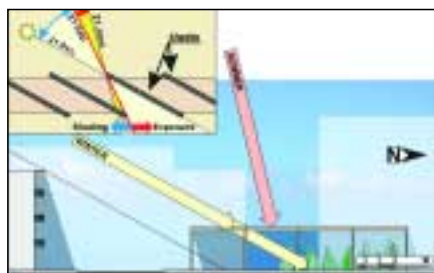

Figure 8.12: Cross section along N-S.

9. SOCIAL CONSIDERATIONS AT THE DESIGN OF OPEN SPACES

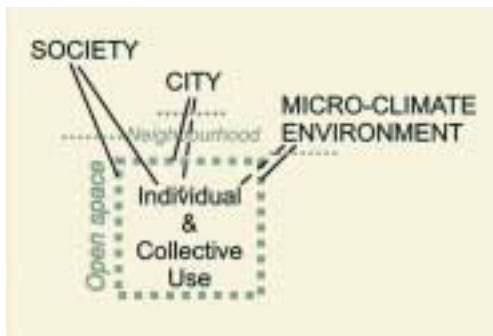

Figure 9.1: Scheme of the social and physical interrelations to be taken into consideration at the design process.

9.1 Introduction

The comfort design of open spaces is a refined form of urban design, aiming to improve the social conditions within the contemporary urban context by focusing on the physical properties at the microscale of open spaces. The aim of this chapter is how to connect the *social issues* experienced in the contemporary urban life with the *physical properties* characterising an open space.

It is quite clear that for the *use of an urban open public space*, social organization and structure, cultural and economic aspects, interrelate with basic human functions of communication, movement and comfort. It is clear as well, that the spatial conditions prescribe in a certain manner the people's activities within the open space (Fig. 9.1).

In the framework of the RUROS research project the relationship “people - physical conditions of open spaces” has been investigated with social surveys, as explained below:

- The surveys that took place were based on different questionnaires (technical questionnaires with social specification, social questionnaires with urban specification) adapted to a *variety of conditions* (different targeted population groups, different open spaces in different countries, different cities with different surrounding urban contexts).
- The *quantitative study* focused on actual uses and users of an open space, evaluating data collected by directly asking people (8500 users) at 14 different open spaces, at 7 different cities across Europe.
- In the Social Surveys, information has been collected by directly asking people (400 inhabitants) within the surrounding areas of 6 open spaces of 3 municipalities (Alimos, Thessaloniki and Themi in Greece). Surveys on three open spaces (two spaces in Alimos and one in Themi) were selected for the pilot application of the RUROS results and combined with parallel studies; an *anthropological study* in Alimos and Themi with a specific population group (selected families within old local inhabitants), and a *social-urban survey* with the type of urban open space (addressed to 25 local residents-users of 10 open spaces selected to be representative for Alimos).
- The *qualitative study* focused on the people's perception about the overall function of an open space: Firstly by focusing on the interest of interviewees themselves - mainly through their personal relationships and perception on the open space - and secondly, by analysing the responses obtained from the different field surveys and quantifying the analysed categories.



Figure 9.2: Scheme of the method proposed for the analysis aiming to social and physical connection within the design process.

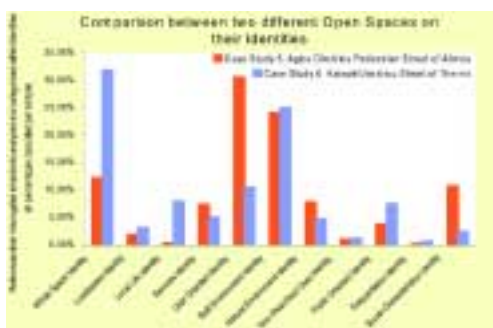

Figure 9.3: The overall function of 2 different sites, analysed from the Social Surveys in Alimos and Themi.

The *issues* and *indicators*, which have arisen, link together the overall social function of urban open spaces and the descriptive analysis of selected open spaces with the urban design procedure.

The method outlined in this chapter is based on the RUROS empirical results. It will help the designer to describe an open space and follow-up its transformation (Fig. 9.2). The aim of this method is to consider all aspects of Open Spaces and their impact at the social level. The initial step is to define these aspects and characterise their overall function and conditions. Changing the overall conditions of an open space, the designer can then proceed by identifying any issues that interfere with the comfort design and try to evaluate them.

Specific Tables have been developed as a system to organise the description of the Open Spaces. Each Table refers to an *identity*, which an open space is perceived and identified from people (user, inhabitant, decision-maker, designer, other agent). Each identity refers to specific issues in contemporary urban open spaces, which constitute a grid for gathering information of an open space. These issues could be investigated, through observations or surveys, and analysed as *variables*. The descriptive data collected may be grouped into *categories*, related to the different physical factors with impact on social level. These categories can be used as statistical units to compare different open spaces or to quantify a social, economic, cultural aspect (as shown from the examples of Figures 9.4, 9.5, 9.6 and 9.7) or even to evaluate a policy or a programme. They can also be used as *indicators* in the design process. For that, the categories inside each Table are ordered according to the decreasing importance, as evaluated from the surveys. Their number, their content and their relative importance should be examined separately for each Open Space studied, as it can change from one case study to another. All identities of the following Tables characterise an open space as shown in Figure 9.3 and therefore they can be evaluated when changes occur in the space.

Overview of the method

Approach the overall function of the open space and report by following steps:

Step 1: Record the urban significance of the open space ➔ **Step 2:** Record its community significance ➔ **Step 3:** Record the actual uses
➔ **Step 4:** Record the actual categories of users

- Identify each aspect separately by using the tables:

Identities: Perceptual issues characterising the Open Spaces overall. All aspects may be considered for each Open Space under consideration.

People (user or designer) perceive an urban open public space in a dynamic manner. In order to express their views, they identify the same open space within *various* aspects, at different scales. As a whole entity, within its surroundings, by considering the local life, evaluating the services, relating with activities and functions that could potentially take place, relating with individual or collective social-economic needs and expectations, proposing specific built features, imagining through natural features, observing non-prescribed even non-conforming uses, feeling with the public-user there, through personal preferences for using the space and in function of the social, cultural or economic background.

Variables: Issues concerned with urban design rules of open spaces by identity (numbered from 1 to 34 within the Tables). Could be investigated independently by selecting an approach valid to the content of each issue, by collecting information (background study and/or observation and/or directly asking people).

Categories: Corresponding to each variable. Empirical issues including physical features with social impact referring to the RUROS context. Number, content and importance of categories may be considered for each Case Open Space and for each transformation.

The reference [A] or [B] within the Tables indicates that the order of categories (numeration by decreasing percentage) corresponds to the quantified data related to a sample of the RUROS Social Surveys or of the Technical Surveys respectively. It is also possible to use these, simply by checking the proposed categories.

- Select within the Tables which categories may be influenced or affected from the planning and the comfort design by using them as indicators:

Related Indicators: In the design process, each category could be defined as an indicator in relation to the purpose, the means and the selected method of the designer or of the decision maker.

The examples for the development of indicators are related, in this Chapter, to the social profile of open spaces or of their surrounding areas. Other technical parameters or factors could be developed as indicators to balance specific social and environmental aspects articulated at different levels within the Tables.

9.2 Urban significance of open spaces

An open space, existing or future, is a significant site in the city. The site comprises in fact the whole space with its localisation context. People indeed perceive an open space as such, i.e. at an urban scale. In order to express their views, they identify the open space to a *whole spatial or usage entity* by referring to a dominant urban function, to a physical property (e.g. "it's a confined space"), to its cultural significance.

Similarly, the open space identity could be recognised by people with its *localisation*, i.e. the open space is not distinguished from its surrounding or even from the greater urban environment. It depends on the site's reach into the city, on the geomorphological conditions of the wider area, on the social organization and structure with impact on the locality, on the geo-climatic regional conditions.

Issue:
Reach of the site in terms of local use

Measurement:
- Share of **USERS** with current residence in the site's surrounding area

	Local inhabitants %	Non local inhabitants %
Predominant local impact		
1 Karaiskaki square	71	29
4 Makedonomahon square	52	48
5 Kritis square	71	29
8 Jardin de Pérolles	71	29
9 Petazzi square	86	14
10 1 ^{er} Novembre square	68	32
14 Peace Garden	79	21
15 Barker's Pool	82	18
16 Florentiner Platz	60	40
Predominant supra-local impact		
2 Sea Shore	38	62
7 Place de la Gare	48	52
12 All Saints passage	37	63
13 Silver street	24	76
17 Bahnhofplatz	44	56

Figure 9.4: Indicator for the social reach of different open spaces, developed from the analysis of the 14 sites in Alimos, Thessaloniki, Fribourg, Milan San Sesto, Cambridge, Sheffield and Kassel.

Site parameter of the overall function of open spaces

Whole Space Identity	Categories
1. Urban public function (prescribed from legislative rules)	1. Street, 2. Square, 3. Pedestrian street, 4. Park/Garden, 5. Leisure Area, 6. Urban Front Place, 7. Urban Island, 8. Grove/Coppice [A]
2. Physical - environmental property	1. Space (general concept of urban shape), 2. Lung of the city (e.g. air source), 3. Free space (breakage in the built environment e.g. for earthquake), 4. Open space (e.g. openness for wide view), 5. Point of reference [A]
3. Social, economic, cultural, political significance	Social-economic character (e.g. market place), Aesthetical recognition (e.g. architectural monument of Renaissance), Historical-political significance (in relation to a specific event)

Localisation Identity	Categories
4. Urban context	Adjacent built area (e.g. 1. bordering buildings, 2. perpendicular streets [A]), Surrounding area (mix and densities of land-uses), Greater urban zone or metropolitan area (city centre, city fringe/outskirts, suburbs)
5. Geomorphological context	1. Landscape element (e.g. seashore), 2. Topographic feature (e.g. hill) [A]
6. Local institutional context	1. State with territorial impact (neighbourhood, municipality, city), 2. State with citizen impact (associations) [A]
7. Geo-climate context	Earth zones



Figure 9.5: Indicator for the impact on local development of different sites, developed from the analysis of the 2 sites in Alimos and Themi.



9.3 Community significance of open spaces

An open space is a complex knot of social, economic and cultural activities in the local community. It constitutes a reason for using the site, as well as for the local development, and for the settlement in the surrounding area (Fig 9.5).

Socio-cultural activities that can potentially take place in an open space are relevant to its function in the community framework ("minimal social structural unit of some kind" [5]). People reveal their practical views about open spaces (e.g. "activities for children should take place", "a bazaar should take place for Christmas"). Also, the services provided to the citizen, the *social-economic-cultural infrastructure* of the site, constitute an important issue for people to consider. They have expectations for more social comfort (e.g. "better police supervision" or "less camera surveillance") or reasons for annoyance (e.g. "dirty" or "too clean").

Community Activities and Organization parameter of the overall function of open spaces

Local Life Identity	Categories
8. Organised collective activities	1. Cultural, 2. Scholar, 3. Sporting, 4. Celebration, 5. Commercial, 6. Political, 7. Religious, etc [A]
9. Spontaneous activities	1. Street happenings, 2. Ceremonial festivities (e.g. Greek custom of paper-kite for Koulouma) [A]

Services Identity	Categories
10. Maintenance	1. Cleaning, 2. Equipment preservation, 3. Natural preservation [A]
11. Accessibility	1. Public passage and citizen usage, 2. Comfortable passage for pedestrians, children and people with disabilities [A]
12. Safety	1. Guarding, 2. Traffic regulation [A]

9.4 Effective/Actual uses within open spaces

During everyday life within an open space, different people, activities and frequencies may be observed. These effective / actual uses of the open spaces are the effects of interactions of *human, spatial and social* (including economic, political, cultural, historical, ethnical) factors.

From the analysis in the RUROS project, it has been found that the human, spatial and social interaction determine the contemporary public use of an open space and is strongly related to the daily life of individuals. These correlations vary for individuals or population groups but, nevertheless, they depend on the overall function of the open space.

The uses of an open space are generated from people at every moment. It is not the same for the built space, which is the product of a complex political, economic and social but concrete operation, where its shape frequently withstands for centuries.

Human parameter of the overall function of open spaces

The empirical results concerned with people perception's have shown that the identity of an open space corresponds to *individual oriented* activities or functions such as physical activities (walking, sitting, standing, sporting, playing, etc categories that appeared with the highest rates within the whole body of analysis data), psycho-physiological functions (not defined or not identified with precise activities) and the plain social and economic functions and activities.

User Oriented Identity	Categories
13. Activities and Functions related to Human Physiology	(a) Physical activities (all variants of 1. sitting free, 2. walking, 3. sitting as consumer, 4. standing, 5. sporting, 6. playing with a child/person/animal, 7. playing social games / chess / bowling) [B] (b) Psycho-physiological functions (e.g. ordered according to the quantified analytical categories within the responses of 320 selected people of ten sites in Alimos and one site in Themi: 1. rest, 2. recreation, 3. relaxation, 4. escape, 5. freedom, 6. amusement, 7. contact with nature, 8. aesthetical feeling, 9. comfort feeling etc)] [A]
14. Social and Economic Activities and Functions	1. Social functions (meeting company, social communication, participating to collective activity), 2. Social-economic activities related everyday life necessities (shopping, escorting children, etc) [A]

Intra-site specifications parameter of the overall function of open spaces

Some activities within an open space are determined by its form and its equipment. The empirical results have shown that people could assimilate an o.s. with its sub-areas (providing prescribed uses) or even with its technical equipment. The built environment is a subject of strong criticism related to the comfort of users and to the specific conditions of each space. On the other hand, the natural environment was related, as expected, to expectations and ideal function of open spaces. The public character of an open space implies also non-specified uses, not compeled from space conditions. Conflicts between specified and non-specified uses (e.g. “making difficult the pedestrian passage by cars”, “using public space as their own yard”, “violation by private company”) often surface during the everyday life of a space, as much as within its urban evolution. It is important to observe such uses moreover to take into consideration such consequences of the design of an open space.



Built Environment Identity	Categories
15. Sub-areas prescribing specific uses (various places and ways)	1. Place to sit with food/drink consumption, 2. Place for children play (playground), place for other play activity, 3. Traffic way (cars/motorbikes, public transport), 4. Commercial dealing place, 5. Pedestrian way, 6. Place to sit free, 7. Parking place, 8. Place for sporting, 9. Bordering buildings' place, 10. Bicycle way, 11. Public transport/taxi station, 12. Other within site buildings or constructions, Persons with disabilities way, Place to lie/to rest extended free, Place for waiting, Place for dogs, Underground entrance [A]
16. Technical Equipment prescribing specific utilities (various furniture and materials)	1. Ground material, 2. Ground colour, 3. Benches, 4. Swings, 5. Street lighting, 6. Buildings colour, 7. Traffic lights, 8. Garbage bins, 9. Fountain/Drink water, 10. Fence, 11. Phone-booth, 12. Posters-box, 13. Camera system, 14. Toilets, etc. (strongly depending on specific Open Space) [A]
Natural Environment Identity	Categories
17. Urban Vegetation	1. Green share, 2. Kind (trees, flowers, grass) [A]
18. Atmosphere	1. Air (air quality e.g. a. clean air, b. oxygen, c. sea iodine), 2. Day light, 3. Temperature (air temperature), 4. Sound, 5. Sun (solar radiation), 6. Wind (wind speed), 7. Humidity [A]
19. Biotope character	1. Geological material (e.g. a. earth soil, b. water), 2. Flora related local biotope, 3. Wild Fauna (e.g. a. birds, b. other animals) [A]
Non-Prescribed Uses Identity	Categories
20. Affecting/declining the existing spatial conditions	1. Space subdivision, 2. Maintenance of equipment [A]
21. Affecting/declining the existing regulated use	1. Specific user group accessibility, 2. Public accessibility [A]

9.5 Categories of open space users

The users of an open space, namely the occasional visitors and the more or less frequent users or actors, even the potential visitors and users, are, in a broader sense, the *public* of the urban open space. The proportion of the different user groups indicates the social profile of each open space.

Social Profile parameter of the overall function of open spaces

People perceive different characteristics of users who use the open space regularly or occasionally, either from visiting the space or from living or working nearby. Urban adjustment and adaptation interrelate with the personal needs and social expectations in interaction with the formal identities of each open space. The open space identity is linked to various categories of users as it has been shown from the empirical results. The age constitutes a very important factor in the classification of users, as does also the character of the general or wide public without distinctions, followed by the different personal relationships, family relationships and the designation of all categories of users for each site.

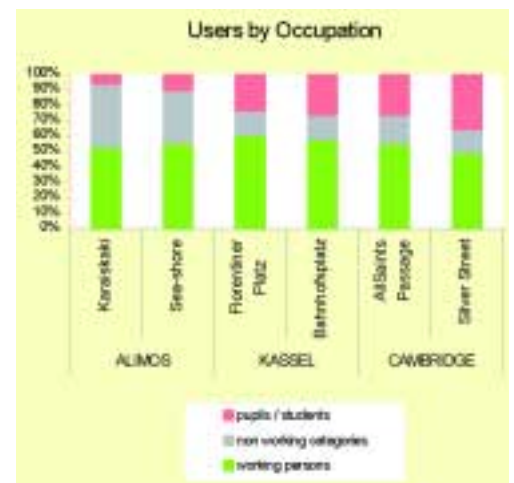

Figure 9.6: Indicator for social profile identity of different sites, developed from the analysis of the 6 sites of Alimos, Kassel and Cambridge.

Public Oriented Identity	Categories
22. Urban non-personalised relationships	1. General public, 2. Specific user group (car-drivers, foreigners, local inhabitants, immigrants, musicians, politicians, stray dogs, suspicious people, tourists, etc.), 3. Specific professional group (guards, gardeners, etc) [A]
23. Urban personalised relationships	1. Family group (e.g. parent/s with children, grandparent/s with grandchildren), 2. Other personal relationship group (a. friends, b. baby-sitters with children, c. persons with dogs, etc) [A]

Frequency Identity	Categories
24. Reason of actual use (Users by single or combined actions related to any issue within tables)	1. escorting child to play, 2. meeting, 3. crossing through, 4. walking, 5. drink/food consumption, 6. relaxation, 7. circulation-transport reason, 8. leisure, 9. shopping, 10. work break, 11. site's natural environment, 12. work, 13. urban-architectural-historical significance of the site, 14. sports, 15. kill time, 16. site's spatial advantages, 17. cultural event, 18. personal business, 19. distraction, 20. site's services, 21. culture-education, 22. escort somebody, 23. sociability, 24. participation to a mass meeting, etc. [B] Related Indicators: Example 1 arisen from a sample of 6500 users from 12 sites in Europe surveyed during 2 weeks at different seasons in 2001 by grouping the previous categories as following: 1. for leisure (31,06%), 2. for personal reasons (21,63%), 3. for consumption (12,93%), 4. for cross through (12,45 %), 5. for site's advantages (10,49%), 6. for work (5,31%), 7. for a break (5,08%), 8. for cultural-education reason 1,05%), 9. for participating to a mass meeting (0,01%) [B] Example 2 as in Figure 9.5 (sample of 1900 users from 2 sites in Fribourg City surveyed as previously [B]
25. Place or activity before actual use	1. at home, 2. shopping, 3. at work, 4. at a place related to education (e.g. school, university, any course), 5. at a social activity (e.g. wedding), 6. at a personal business (e.g. doctor), 7. on the way (e.g. bus), 8. at an artistic/cultural activity (e.g. concert), other [B]
26. Time of use	By daytime (morning, midday, afternoon, evening, night), By day of the week (weekday, holiday period), By season (summer, autumn, winter, spring)
27. Frequency of use	1. Frequent user (a. daily, b. weekly, c. monthly [B]), 2. Occasional user (a. yearly, b. sometimes, c. first time [B]), 3. Potential user (non-user at present)

Background Social Characteristics Identity	Categories
28. Age	1. Children, 2. Little children, 3. Elderly persons, 4. Young persons, 5. Babies, 6. Adults, 7. Teenagers [A]
29. Residence	1. Local inhabitants, 2. Non-local inhabitants [B]
30. Main Occupation	1. Working persons, 2. Pupils/Students, 3. Pensioners, 4. Non-working persons [B]
31. Origin	Geographical groups regrouped with social-cultural criteria specific for the local society (e.g. countries/towns/villages of provenance of tourists, of immigrants)
32. Household	Single person, Cohabitation without children, Family with children, Extended family
33. Gender	Men, Women
34. Education Level	Primary, Secondary, Higher all levels

9.6 Description and Evaluation Criteria

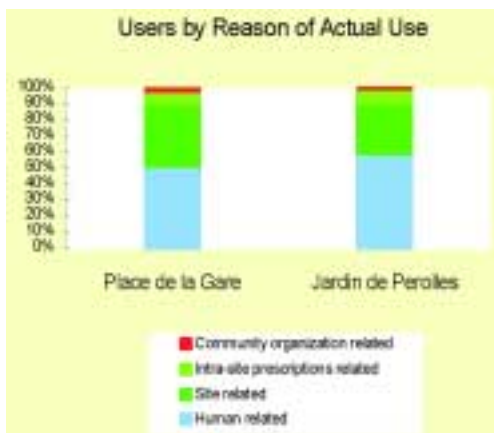

Figure 9.7: Indicator for the frequentation identity of different sites in the same metropolitan area, developed from the analysis of the two sites in Fribourg.

Designing to achieve comfort conditions, could change the physical conditions of an open space. In this transformation procedure, the performance of each design for existing or new open space has to be assessed at a collective level. This has to be evaluated through time, by relating social objectives with the actual individual physical comfort levels. Critical aspects related to uses developed in a space - on site or intra-site level - or to user groups have to be recognised, taking into consideration the overall function of the open space. However, conflicts could exist at a present design stage or could even emerge in the future.

Open space information organised by identities concern a situation given in time. Though, it is important to compare different situations or different open spaces, in real or virtual conditions, in order to evaluate the desirable as well as the unwanted changes. The factors that describe and evaluate a transformation of an open space are: the different categories as a criterion of variety, how many and which categories are the most frequent as a criterion of dominance, and which categories have not been observed at all as a criterion of absence. This method could be applied for different conditions and time periods during the day (Fig 9.8).

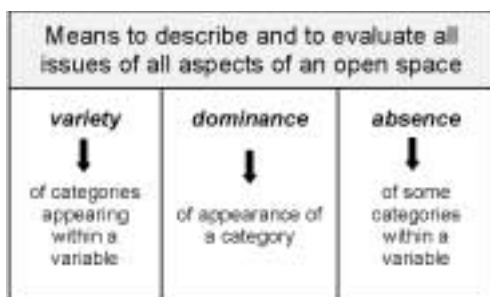

Figure 9.8: Means to describe and evaluate all issues of all aspects of an open space.

9.7 References

- [1] Anderson, S. (ed.) (1986), *On Streets*, The MIT Press, Cambridge Massachusetts.
- [2] Basham, R. (1978), *Urban Anthropology: Cross-Cultural Study of Complex Societies*, Mayfield Publishing Company, California.
- [3] Gourdon, J.-L. (2003), "Paris - «La rue on partage», il dépend comment", in *Revue Urbanisme*, No 329, Paris.
- [4] Moudon, AV. (ed.) (1991), *Public Streets for Public Use*, Columbia University Press Morningside Edition, New York.
- [5] Southall, A. (ed.) (1974), *Urban Anthropology: Cross-Cultural Studies of Urbanization*, Oxford University Press, London.

10. EVALUATION OF TOOLS

10.1 Introduction

This Chapter provides an evaluation of the different tools and methodologies presented in the previous chapters, for the main design proposal, Karaoli and Dimitriou (described in Section 8) in Thermi. The physical environment of the area is identified and analysed for its environmental performance and the social parameters and characteristics of the different population groups in the area.

10.2 Thermi pilot application

10.2.1 Thermal comfort

In order to examine the thermal comfort conditions in the area, the model to predict ASV for Thessaloniki (Section 1.4.1) is employed with the respective climatic data.

$$ASV = 0.036T_{air_met} + 0.0013Sol_{met} - 0.038V_{met} + 0.011RH_{met} - 2.197$$

Data for the mean maximum air temperature, with intense insolation, no wind (i.e. still conditions) and high relative humidity due to its proximity with the sea, are included in the equation. Thus:

$$ASV = 0.036 \times 33 + 0.0013 \times 1000 - 0.038 \times 0.5 + 0.011 \times 70 - 2.197 = 1.04$$

Reading the percentage of people feeling comfortable in the summer from Figure 1.7, the value reaches 65%. Thus shading is required for the summer period. Providing shading in the form of pergolas:

$$ASV = 0.036 \times (33 - 1) + 0.0013 \times (1000 \times 0.2) - 0.038 \times 0.5 + 0.011 \times 70 - 2.197 = -0.03.$$

Figure 1.7 shows that 90% of the people would feel comfortable in such conditions, with only 10% found in the discomfort zone, a figure accepted even in well-controlled indoor environments. Similarly, different seasons and different problems can be evaluated.

Furthermore, to maximise use of space the design should provide solutions for both summer and winter with the respective daily fluctuation, maximising the available personal choice. For that, some of the sitting is suggested to be placed underneath the gallery, to maximise use at different seasons, allowing resting places for winter as well as in the summer, where users seek the shade.

10.2.2 Wind environment

The prevailing wind direction is NW all months except for August, when the prevailing direction is S. The annual mean wind speed is $5.5\text{m}\cdot\text{s}^{-1}$, with small variations during the year, as measured in the nearby airport. The area under consideration is a linear space divided into four sections (A-D) each 70-100m long and placed on an approximate EW axis.

The measured wind speeds from the airport can be transferred to an approximate wind speed above the case study site using Table 2.2. It is presumed that the airport is situated in open land, while the space is situated in suburban area. It is also presumed that the height of the suburban area is 20m (the height above ground level where the wind pattern will be not affected by local obstructions).

Thus $S = \frac{VH}{V10} = \frac{20}{27.4} = 0.73$ and the mean wind speed above the urban area can be calculated. Annual mean wind speed is $4.0\text{m}\cdot\text{s}^{-1}$ (Winter = $4.1\text{m}\cdot\text{s}^{-1}$; Spring = $3.9\text{m}\cdot\text{s}^{-1}$; Summer = $4.5\text{m}\cdot\text{s}^{-1}$; Autumn = $3.7\text{m}\cdot\text{s}^{-1}$). This is not a critical wind speed, in respect to the $5\text{m}\cdot\text{s}^{-1}$ criteria in Table 2.1.

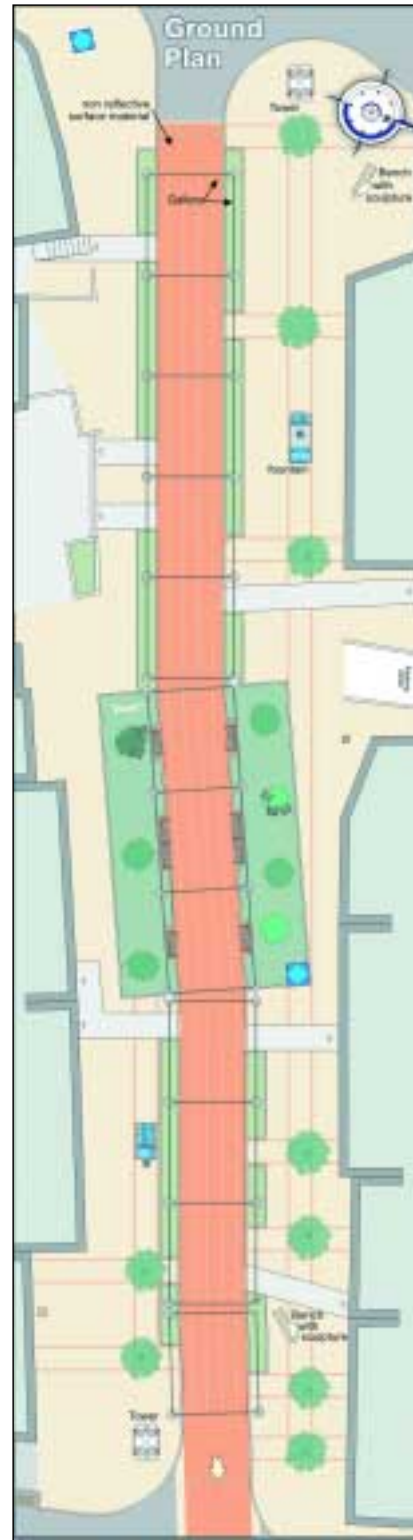

Figure 10.1: Plan view and picture from the physical model of the design proposal.

On pedestrian level both the wind direction and the wind speed will be affected by the layout of the suburban area. The following observations can be made from the drawings.

The space is linear, around 200 m long in total, thus there is a danger that the building façades and the central roof covered pedestrian area can create a channel effect and speed up the wind (if more than 100-125 m). However the design includes a number of features to reduce this risk.

- The prevailing wind direction is across the main axis of the street.
- The presence of the trees in the street will reduce the risk of channel effect due to the wind breaking effect of these. This effect will be increased if the trees are placed with irregular distance to the building façades because trees placed in a straight row can also form a kind of channel especially when the wind direction is parallel with the main axis of the street (West or East).
- The 'extra' trees placed around the four grass covered squares (one in each section) is for the same reason a very good idea. In general, the more trees placed in these green areas, the better. With enough trees the green areas will form a kind of wind gate breaking up the street in smaller lengths where the wind cannot accelerate.
- The building façades are not placed in a straight line along the street. There are several niches and recesses, which provide resistance to the wind.

10.2.3 Evaluation of radiant conditions



H/D = 0.43 → reference street = 0.36 EO
or H/D = 0.75 → reference street = 0.69 EO

Figure 10.2: Plan view of the design proposal with the different areas where the radiant environment is evaluated (A, B and C, also see Tables on the left).

Reference street h/d = 0.36

Morning AirT30°C	Albedo = 0.2	Sun protection	Albedo = 0.8	Sun protection
A, B, C (sun)	24.5/35	15/23	20/31.5	14.5/18.5
Midday AirT33.5°C	Albedo = 0.2	Sun protection	Albedo = 0.8	Sun protection
A, C (sun)	43.5	35	32/36	18.5/26
B (shade)	25	—	23	—
Afternoon AirT37°C	Albedo = 0.2	Sun protection	Albedo = 0.8	Sun protection
A, C (sun)	42/52	33/42	39/43.5	27/31.5
B (shade)	26	—	25.5	—

Reference street h/d = 0.69

Morning AirT26°C	Albedo = 0.2	Sun protection	Albedo = 0.8	Sun protection
A, B, C (sun)	25.5/36.5	17/24	24/32	16/18
Midday AirT33.5°C	Albedo = 0.2	Sun protection	Albedo = 0.8	Sun protection
A, C (sun)	43.5	35	32/36	24.5/27
B (shade)	35.5	—	33	—
Afternoon AirT37°C	Albedo = 0.2	Sun protection	Albedo = 0.8	Sun protection
A, C (sun)	42/52	39/43	40/44	25.5/32
B (shade)	31	—	29.5	—

Karaoli-Dimitriou is a street with an EW orientation. The surrounding façades have different heights. For this reason two ratios have to be considered as reference streets, h/w = 0.69 as well as h/w = 0.36.

From the analysis in Section 3, in the *early morning*, the sunny areas paved with albedo material of 0.2, as well as of 0.8, are in comfort conditions even without shading device. The area B is in the sun for some time. It would be convenient to shade it with temporary devices, if seating activities are to be located there.

Mrt 20°C (unsh.) → PET = 22°C Mrt 30°C (unsh.) → PET = 26.3°C
Mrt 25°C (unsh.) → PET = 24°C Mrt 35°C (unsh.) → PET = 28.7°C

At *midday*, the area B is in comfort conditions. Area A and C, however, are very critical. It is thus necessary to combine shading devices and clear materials to get acceptable thermal comfort conditions.

Mrt 20°C (shad.) → PET = 27.1°C Mrt 35°C (unsh.) → PET = 34°C
Mrt 25°C (shad.) → PET = 29.3°C Mrt 40 (unsh.) → PET = 36.5°C
Mrt 30°C (unsh.) → PET = 31.6°C

In the *afternoon* the situation is similar. However a longer exposure to solar radiation determines higher MRT values and therefore cooling devices are recommended (use of water, evaporative surfaces, etc.).

Mrt 25°C (shad.) → PET = 32.5°C Mrt 35°C (unsh.) → PET = 37°C
Mrt 30°C (shad.) → PET = 34.7°C Mrt > 40°C (unsh.) → PET > 39.4°C

In terms of activities the following are suggested. In the morning, it is possible to make settled (as sitting) or dynamic activities (crossing, play for children) in the whole street, keeping in mind the need to protect the south area with moveable devices. At midday and afternoon, it would be better to have short-time (preferably low metabolic) activities. During the afternoon the shaded south area is suitable for settled activities. The other two areas are at the limit of comfort conditions, even with strategies reducing the MRT. Thus it is suggested to include low metabolic activities.

10.2.4 Morphological analysis

The surrounding area of the site has a good mix of all the desirable profiles, and a high amount of skylit and sunny areas (Fig. 10.3). The highest percentage is 24% sky/sun/still, (yellow), which is the most favourable in winter but not favourable in the summer. Cover/shade/still areas (black) are 16%. Also there is a relatively high percentage of sun/cover/still, (green), at 9%, which is the worse case for the Greek summertime and requires shading. Overall the whole area has quite a good mix of the different conditions. The site itself is in quite a desirable zone with the highest percentage sky/sun (yellow) at 32%, favourable in the winter, but requires shading in the summer. The good use of shading devices, in such way that they allow the penetration of winter sun, will be an appropriate design strategy. Moreover, optimising the wind flow through the predominantly sunny areas would be an important aspect to consider with respect to overheating in the summer.

10.2.5 Visual environment

The cover above the street makes this open space visually challenging, limiting the free view towards the sky from the central part of the street, resulting in surrounding façades appearing brighter. A careful selection of ground colours is required, with the proposed asphalt having a higher reflectance than the surrounding pavement, to avoid the effect of «bright» surroundings viewed from a «darker» protected centre, which would be a source of glare. The vegetation planned around the seat benches is appropriate to mitigate this effect, when plants are sufficiently dense to mask parts of the façades at eye level.

The louvers forming the cover are oriented such as to block sun penetration during the summer, while letting the sun pass through during winter. In the latter situation, the repetitive pattern of shaded and sunlit areas that will appear on the ground may become visually uncomfortable. A careful choice of the louvers' sizes and spacing is proposed, to weaken the pattern contrast (as the sun is not a point source but occupies a tiny solid angle in the sky, small louvers dimensions could transform the shade and sun pattern into a relatively homogenous penumbra).

As shown on Figure 10.4, the shading effect provided by the proposed gallery fulfils correctly the requirement for the simultaneous presence of sunlit and shaded areas at street's level in proportions between 20% and 80% (Section 6.4).

10.2.6 Acoustic environment

The soundscape and acoustic comfort consideration is based on the description system shown in Section 7.2. The main noise source is the traffic from one end of the street. Based on the calculation using the radiosity model (Section 7.4.2), the traffic noise level will be below about 50-60dBA at a distance of about 50m. This means that the majority of the area is not significantly affected by the traffic noise, according to the relationship between acoustic comfort evaluation and noise level (Section 7.3.1). It is noted that the street façades are rather acoustically

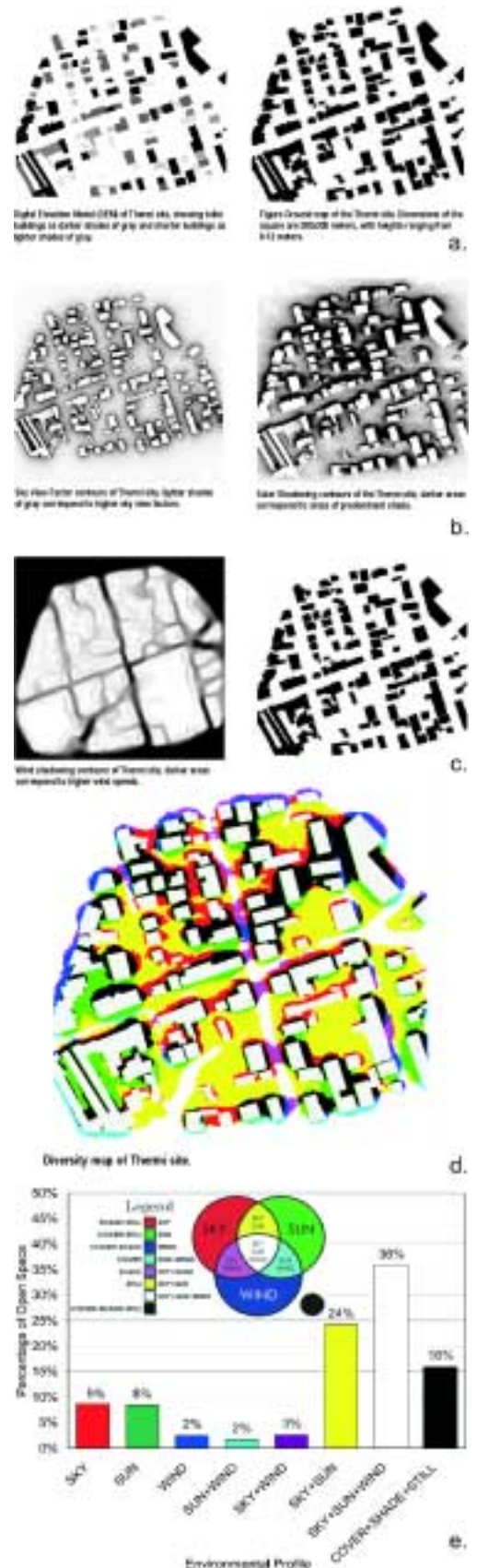

Figure 10.3: (from top to bottom) (a) DEM for the site showing highest buildings as darker sides of grey with a maximum height of 12m. (b) Left-SVF contours, lighter shades of grey correspond to higher SVF, right-solar shadowing contours, darker shades correspond to areas of predominant shade. (c) Wind shadowing contours, darker areas correspond to higher wind speeds. (d) Diversity map of Thermi. (e) Environmental open space diversity profile for the area.

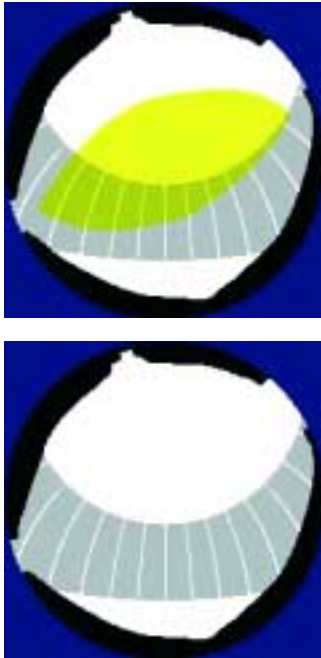

Figure 10.4: Application of the multistereographic projection analysis method (as described in chapter 6.4) for the Thermi pilot application:

Top: street without gallery (present situation). Direct sun penetration appears too large for several months (sunpath overlaps the yellow zone).

Bottom: street with the proposed gallery. Sunlit and shaded areas occupy the right proportions of the street during the whole year.

diffuse and this is very beneficial for increasing sound attenuation as well as for reducing reverberation (Sections 7.4.4 and 7.4.5). Street furniture, including trees, is also useful for diffusing sounds.

However, it would be useful to have a noise barrier at the street end to extend the area of good acoustic comfort. A concrete barrier was designed, with vegetation on it to further absorb noise and a running water film on the barrier, to generate pleasant sounds, masking the unpleasant traffic noise (Section 7.3.2 and 7.4.6). In the final stage, however, due to financial/functional reasons, the barrier was discarded.

10.2.7 Social parameters involved and use of space

The field survey that was carried out with inhabitants and professionals in the area has revealed important issues. Regarding the urban significance of the space, the site has been identified as Thermi's local centre by 54% of the population. For the community, the circulation of people, cars, busses, is an important aspect according to 61% of interviewees. The anonymity and the impersonal relationships of the urban social conditions have interfered with the rural life of the local community.

Foreigners/immigrants constitute an important group of users mentioned by 34% of the interviewees. Prevailing activities of the tertiary sector and cultural events, in this very dense area, was mentioned by 90% of the interviewees, at local and supra local level. A small number (7%) also reported user groups, such as music, dance groups and the politicians related to the cultural and political events taking place there.

The intra-site spatial conditions are related to a number of important uses according to interviewees. 56% referred to the need for more parking spaces. As a central commercial street is connected to the movement and traffic characteristics of the site, the shaping of better passage conditions adapted to the specific use, form a dominant expectation.

Vegetation is also related to the expectations of interviewees (49%) for the site. Better lighting seems to be an important need. Urban equipment, such as street lighting and benches, are expected in the area (49% and 37% respectively). Places to sit for drink/food consumption are also important (27%). 32% mentioned the importance of a playground, while the need for bigger pavements is mentioned by 12%.

Regarding the urban personalised relationships and local community scale, meeting a friend, provides a significant reason for using open spaces, for different age categories. This non familial category of personal relationships is characteristic for the 'public oriented identity' of the site in the present situation.

The psycho-physiological functions of recreation, rest and amusement are significant characteristics for the site as well open spaces inside the urban tissue. Strolling, gathering of people and shopping, are the main activities of individuals in the area, providing significant reasons for the use of the site, related to the central commercial centre of the area in the context of the small locality. The cleaning and guarding are also reported to be significant aspects in the context of the community

In summary, the area is visited by citizens for its shops, places for drink/food consumption, its open space and for the children to play. The proposed pedestrianisation of the street is significant for such activities, uninterrupted by vehicular traffic. Furthermore, designing to improve the physical environment, as described in this Chapter, providing thermal-visual-acoustic comfort conditions, will strengthen these activities, allowing closer social interaction for different groups of population.

GLOSSARY

Actual Sensation Vote (ASV) People's thermal sensation, defined within the RUROS project, evaluated on a 5-point thermal sensation scale (too cold, cool, neither cold nor warm, warm, very hot). In the calculation of the models presented in Section 1, it is primarily affected by air temperature and wind, as the effect of solar radiation is masked by that of air temperature due to their close correlation.

Adaptation The gradual decrease of the organism's response to repeated exposure to a stimulus, involving all the actions that make them better suited to survive in such an environment.

Albedo Fraction of incident solar energy that is reflected from one surface.

Channel Effect Where the wind can accelerate between linear urban structures and create an unpleasant windy environment.

Computational Fluid Dynamics (CFD) Type of software, which can simulate airflow in detail. In this context it is used as a virtual wind tunnel.

Cylindrical Illuminance In order to relate users' sensations with the physical characteristics of the luminous field, a representative parameter has to be measured. The first idea to come in mind is to measure the horizontal illuminance level (in [lx]) using a luxmeter with a sufficiently large measuring range (outdoor illuminance levels can easily exceed 100,000lx in sunlight). However, horizontal illuminance is a measure of the amount of light reaching the site but not people's eyes which are mainly vertical receivers. As shown on figure 1 (bottom) a horizontal luxmeter does not take into account ground reflected light which obviously reaches people's eyes. Furthermore, although vertical façades occupy a large part of the users' field of view, horizontal illuminance severely undercounts the light coming from the façades located close to the horizon.

A better parameter to measure is the "cylindrical illuminance" level (i.e. the amount of light reaching a tiny vertical cylinder) for which a specific sensor has to be used. Cylindrical illuminance takes into account the light coming from all directions. Hence for a specific location, this measurement characterizes all possible gaze directions. Figure 1 (top) shows a portion of the space as viewed from a cylindrical illuminance sensor. The similarity with a normal perspective picture clearly appears.

The cylindrical illuminance at a specific location can be calculated using a simplified approach:

$$E_{cyl} = \pi^2 \cdot (f_{sky} \cdot L_{sky} + f_{buildings} \cdot L_{buildings} + (1 - f_{sky} - f_{buildings}) \cdot L_{ground}), \text{ where:}$$

L_{sky} , $L_{buildings}$ and L_{ground} are the mean luminances of the sky, the buildings and the ground respectively.

f_{sky} and $f_{buildings}$ are "form factors" giving the proportion of the sky and the buildings as "seen" from the specific location. Both are comprised between 0 and 1 and $f_{sky} + f_{buildings} < 1$

Down Wash Vertical wind flow running down the façade of a building. Originates usually from a horizontal wind, which is deflected down by the building façade.

Digital Elevation Model (DEM) A regularly spaced matrix of elevation values, which contain 3D information in a 2D digital format. It is represented as a 256-colour grayscale image, where the grey level is proportional to the height of the buildings.

Environmental Diversity The degree of variety which exists in an area due to the combination and interaction of morphological and microclimatic parameters.

Equivalent Sound Pressure Level Ten times the logarithm to the base ten of the ratio of the time-mean-square instantaneous sound pressure, during a stated time interval T, to the square of the standard reference sound pressure (ANSI 1994).

Figure Ground Map A binary (black and white) image where the 'figure', corresponding to the built-up areas, are highlighted in black against a white background, which corresponds to the open spaces.

Geostrophical Wind The free undisturbed wind high above the surface of the earth is called the geostrophical wind. The speed and the direction of the geostrophical wind is only influenced by pressure differences in the atmosphere and by the rotation of the Earth. Wind below the geostrophical wind is also influenced by the typography of the surface of the Earth.

Geostrophical Height The lowest height above the surface of the earth where the geostrophical wind occurs. In flat terrain the height varies from around 275m to about 500m depending on the roughness of the surface of the earth. Note that the geostrophical height can be even higher in mountain areas.

Glare The discomfort or impairment of vision experienced when parts of the visual field are excessively bright compared to the general surroundings.

Illuminance The luminous flux incident per unit area, measured in [lx] (Lux or Lumens per square meters).

$L_{10,T}$ The level of noise exceeded for 10% of the specified measurement period (T). It gives an indication of the upper limit of fluctuating noise.

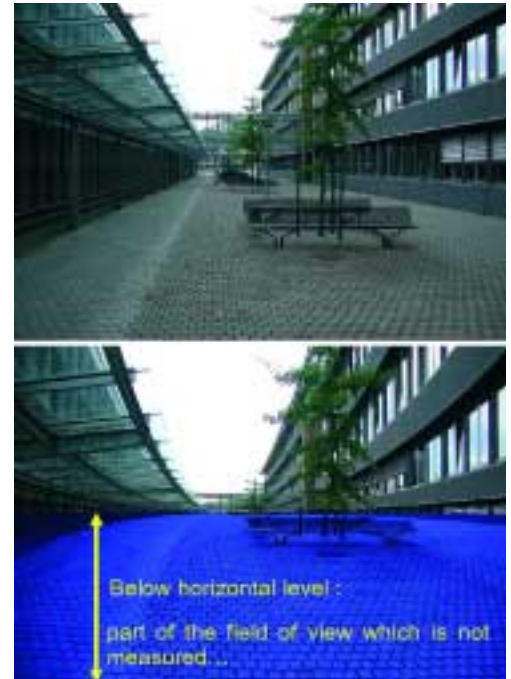

Figure 1: An open space located between two buildings as viewed from a cylindrical illuminance sensor (top) and from a horizontal luxmeter (bottom). Note on the bottom picture the large geometrical shrink around the horizon: the building ground floor almost disappears.

$L_{50,T}$ The level of noise exceeded for 50% of the specified measurement period (T). It gives an indication of the average of fluctuating noise.

$L_{90,T}$ The level of noise exceeded for 90% of the specified measurement period (T). It gives an indication of the lower limit of fluctuating noise.

Luminance The physical measure of the stimulus that produces the sensation of brightness, measured in $[cd.m^{-2}]$.

Luminous Sensation Vote (LSV) An arbitrary 5-point scale (very dark, dark, neither dark nor clear-neutral, bright, very bright) that enables people to assess their sensation regarding outdoor brightness. This scale has been defined within the RUROS project.

Mean Radiant Temperature (MRT) The uniform temperature of a surrounding surface giving off blackbody radiation (emission coefficient $e = 1$) which results in the same radiation energy gain of a human body as the prevailing radiation fluxes which are usually very varied under open space conditions. In other words MRT is the average value of the temperature of the surfaces, solid as well as fictitious (i.e. sky vault), weighted by the view factor.

Mesh Effect The fact that the dimensions of an urban space or an urban area can be designed in such a way that the wind mainly will flow above the space/urban area and not into the space creating uncomfortable conditions in the pedestrian zone.

Morphological Parameters Aspects or features of the urban environment that are the result of urban morphology, which is the three-dimensional form of a group of buildings and the spaces they create.

Multistereographic Projection A kind of stereographic projection obtained after superimposing a series of stereographic projections computed for several points regularly spread over a full area of interest. The resulting view appears as a defocused stereographic projection as if several fish-eye photographs were superimposed together. This allows to assess sun penetration (or shading effects) over the whole area of an open space.

Neutral Temperature The temperature which corresponds to thermal neutrality, i.e. where people feel neither warm nor cool.

Physiological Equivalent (PET) The air temperature at which, in a typical indoor setting (without wind and solar radiation), the heat budget of the human body is balanced with the same core and skin temperature as under the complex outdoor conditions to be assessed. This way it enables a lay-person to compare the integral effects of complex thermal conditions outside with his own experiences indoors.

Porosity A simplified estimation of the blocking effect of urban geometry. Also known as variance plot, or permeability rose. It gives an indication of the roughness of a particular piece of urban fabric and is used to gain further insight into wind patterns within the urban environment.

Predicted Mean Vote (PMV) Thermal sensation index, based on the heat balance of the human body, that predicts the mean value of the votes of a large group of persons on a 7-point thermal sensation scale. It is based on environmental parameters, such as air temperature, mean radiant temperature, wind speed and air humidity, as well as metabolic rate and clothing insulation (ISO 7730, 1994).

Reverberation Time Of an enclosure, for a stated frequency or frequency band, time that would be required for the level of time-mean-square sound pressure in the enclosure to decrease by 60dB, after the source has been stopped (ANSI 1994).

Sky View Factor (SVF) A measure of the solid angle of view of the sky from an urban space. Sky view factor is a measure of the openness of the urban texture to the sky, and is linked to climatological phenomena such as urban heat island, daylighting and heat absorption

Solar Shadowing An overlaid plot of shadow casting that shows the shadowing profile of a particular urban morphological configuration over a specific season or an entire year.

Sound Absorption Change in sound energy into some other form, usually heat, in passing through a medium or on striking a surface (ANSI 1994).

Sound Pressure Level Ten times the logarithm to the base ten of the ratio of the time-mean-square pressure of a sound, in a stated frequency band, to the square of the reference sound pressure (ANSI 1994).

Specific Heat The amount of heat per unit mass required to raise the temperature by one degree Kelvin $[J.Kg^{-1}K^{-1}]$.

Stereographic Projection A representation of the whole hemispherical sky dome as a circular disk with the centre corresponding to the zenith (i.e. vertically overhead), and its circumference representing the horizon. The resulting view can be likened to a 180° fish-eye photograph taken by a photographer lying on his back.
In bioclimatic design, the stereographic projection is often used as a convenient tool to assess shading effects. This is done by superimposing the sunpath diagram with the obstructions due to surrounding buildings.

Sun-hours The average duration of solar exposure a particular area receives during the day, derived from a solar shadowing map.

Sunpath diagram A graphical representation of the directions of the sun as seen in the sky dome from a specific location. The diagram can be drawn for various time periods (e.g. a specific date, a full season, the full year).

Surface Roughness (α) A measure for the frictional drag of a surface (0-1). The higher roughness - the more friction - the deeper boundary layer (the higher geostrophical height).

Thermal Capacity The amount of energy required to raise the temperature of an object by one degree Kelvin $[J.Kg^{-1}K^{-1}]$.

Turbulence An unorganised variation in the mean wind speed and the wind direction, often due to friction against solid surfaces and structures (vertical thermal currents can also create turbulence). Effects are wind gusts, lulls and wind whirls.

Urban Morphology The three-dimensional form of a group of buildings and the spaces they create.

Venturi Effect Special and more critical type of channel effect, where the urban structures form a funnel.

Viewshed The range of surfaces that are visible from an area within an urban space

Wind Rose A graphical overview of the local wind velocities and directions for a specific site based upon measurements over a longer period of time.

Wind Velocity Profile A curve showing the relationship between the (mean) wind speed in a given height above the surface of the earth – usually presented from the surface of the earth to the geostrophical height. Often presented for different types of terrain.

Wise Effect Horizontal wind flow running opposite the main wind direction. Is often a result of down wash.

THE CONSORTIUM

Co-ordinator



Centre for Renewable Energy Sources – CRES, Department of Buildings, Greece
Dr Marialena Nikolopoulou (e-mail: mnikol@cres.gr)
tel: + 30 210 6603300, fax: + 30 210 6603301,2

Other Principal Contractors



Esbensen Consulting Engineers Ltd., Denmark
Niels-Ulrik Kofoed (e-mail: n.u.kofoed@esbensen.dk)



B.E.S.T. Building Environmental Science and Technology Department, Milan Polytechnic, Italy
Prof. Gianni Scudo (e-mail: scudo@mail.polimi.it)



The Martin Centre for Architectural and Urban Studies, Department of Architecture, University of Cambridge, UK
Dr Koen A. Steemers (e-mail: kas11@cam.ac.uk)



Faculty of Urban and Landscape Planning, Department of Climatology, University of Kassel, Germany
PD Dr Lutz Katzschner (e-mail: katzschn@uni-kassel.de)



Haute Ecole Spécialisée de Suisse Occidentale: Ecole d'ingénieurs et d'architectes de Fribourg, Switzerland
Dr Raphaël Compagnon (e-mail: raphael.compagnon@eif.ch)



School of Architecture, University of Sheffield, UK
Prof. Jian Kang (e-mail: j.kang@sheffield.ac.uk)



Laboratory of Building Construction and Building Physics, Faculty of Civil Engineering, Aristotle University of Thessaloniki, Greece
Prof. Niobe Chrisomallidou (e-mail: niobe@civil.auth.gr)

Associate Contractors



National Centre for Social Research, Greece
Dr Eleni Kovani and Kallisteni Avdelidi (e-mail: kavdelidi@ekke.gr)

Municipalities of:

- Alimos, Greece
- Thermi, Greece
- Vile-Fribourg, Switzerland



This publication was co-financed by the European Commission, DG Research, as a part of Key Action 4 «City of Tomorrow and Cultural Heritage» from the programme «Energy, Environment and Sustainable Development» within the Fifth Framework Programme.





**ΚΑΠΕ
CRES**

Centre for Renewable Energy Sources (CRES)
19th km Marathonos Ave., 190 09 Pikermi, Attiki, Greece
Tel: +30 210 6603300, Fax: +30 210 6603301-2, <http://www.cres.gr>



ISBN: 960-86907-2-2