

SIMULATION AND OPTIMIZATION OF GROUND SOURCE HEAT PUMP SYSTEMS

J.D. Spitler, Professor, School of Mechanical and Aerospace Engineering, Oklahoma State University
X. Liu, Research Associate, School of Mechanical and Aerospace Engineering, Oklahoma State University
S.J. Rees, Institute of Energy and Sustainable Development, De Montfort University, UK
C. Yavuzturk, Assistant Professor, Dept. of Civil and Architectural Engineering, University of Wyoming

ABSTRACT

Almost any conventional heating and air-conditioning system may be satisfactorily modeled for energy analysis purposes with a steady-state analysis. Ground source heat pump (GSHP) systems and hybrid GSHP (HGSHP) systems are a clear exception. The fact that ground temperatures may change over a number of years adds some complexity to the modeling effort, and has delayed availability of GHSP and HGSHP models in building energy analysis programs. This paper gives an overview of recent research and developments in ground source heat pump system simulation, design, and optimization. First, developments related to modeling of components of the ground source heat pump (GSHP) system are presented - vertical ground loop heat exchanger, water source heat pump, standing column well, and several types of supplemental heat rejecters used in hybrid GSHP systems. Second, application of the simulation for design of vertical ground loop heat exchangers (GLHE) will be introduced. Third, several applications of using system simulation in the design of GSHP systems will be presented. Finally, preliminary investigations of using the simulation within an optimization procedure will be discussed.

Key words: *ground source heat pump systems, geothermal, ground-coupled*

1 INTRODUCTION

Using the ground as a heat source or sink in an air conditioning system is attractive from a thermodynamic point of view, as its temperature is generally much closer to room conditions than the ambient dry bulb or wet bulb temperatures over the whole year. For this reason, ground coupled heat pump systems are potentially more efficient than conventional air-to-air systems. In practice, ground-source heat pump systems have also proved to have lower maintenance costs due to the absence of equipment exposed to the atmosphere (Cane et al. 1998).

Although some of the technology of ground source heat pump systems has been developed in Scandinavia, the potential for commercial exploitation has perhaps been greatest in the USA. This is mainly because of the large market that already exists for residential air conditioning systems. Systems with lower energy consumption and potentially lower maintenance costs have proved attractive to homeowners. Peak electrical utility demands in much of the USA are determined by air conditioning usage. For this reason there has also been great interest in such systems from electrical utility companies wishing to reduce peak demand. Application of this technology has also been made in the small commercial and institutional sectors. Ground source heat pump systems have proved popular with some school authorities that are particularly attracted by the lower maintenance costs (Dinse 1998; Cane and Clemes 1995; GHPC 2003a). Details of a number of case studies involving application of ground source heat pump technology in the United States have been given by the GHPC (GHPC 2003b, 2003c). Despite limited use of residential cooling in Europe, significant market penetration has been made in some countries. (Lund, et al. 2004).

In the following sections of the paper we set out firstly, developments in modeling the components of the GSHP system, including the vertical ground loop heat exchanger, water source heat pump, standing column well, and several types of supplemental heat rejecters used in the hybrid GSHP system. These models may be used in component-based simulation environments such as TRNSYS (SEL 1996) and HVACSIM+ (Park et al. 1985). In the third section of this paper, software for sizing the vertical GLHE will be introduced. Then, several applications of using system simulation in the design of GSHP systems will be presented, including hybrid GSHP systems and a GSHP based bridge snow melting system. Finally, preliminary investigations of automated optimization of GSHP and HGSHP system designs will be described.

2 MODELING COMPONENTS OF GSHP SYSTEMS

GSHP systems are generally comprised of water source heat pumps, ground loop heat exchangers, and for hybrid systems, supplemental heat rejecters or sources. Modeling of these components is covered below.

2.1 Closed-loop Ground Heat Exchangers

Closed-loop ground coupled systems can use horizontal pipe loops or vertical pipe loops in boreholes. Vertical closed-loop systems are the predominant system type used in commercial and institutional applications. Closed loop ground heat exchangers of this type consist of a borehole of diameter 75-150 mm into which is inserted a loop of pipe with a ‘U’ bend at the bottom. The borehole is then either back-filled or, more commonly, grouted over its full depth. Grouting is normally required to prevent contamination of the ground water and give better thermal contact between the pipe and the ground¹. The pipe used in these systems is typically High Density Polyethylene (HDPE) of nominal diameter in the range 22-32 mm. The depth of the borehole varies between typically 30 m and 120 m.

Two levels of modeling sophistication are of interest. First, it is desirable to have a design methodology that is satisfactory for sizing ground loop heat exchangers with minimal user input and computational time. Second, it is desirable to have a simulation model that can predict hour-by-hour (or shorter time interval) responses of the ground loop heat exchanger to continuously changing building loads. This approach allows the prediction of system energy consumption and electrical demand. Since both approaches presented in this paper are based on the model developed by Eskilson (1987), Eskilson’s methodology will be discussed first, followed by a description of the simulation model developed by Yavuzturk and Spitler (1999).

2.1.1 Eskilson’s methodology

Eskilson’s (1987) approach to the problem of determining the temperature distribution around a borehole is a hybrid model combining analytical and numerical solution techniques. A two-dimensional numerical calculation is made using transient finite-difference equations on a radial-axial coordinate system for a single borehole in homogeneous ground with constant initial and boundary conditions. The thermal capacitance of the individual borehole elements such as the pipe wall and the grout are neglected. The temperature fields from a single borehole are superimposed in space to obtain the response from the whole borehole field.

The temperature response of the borehole field is converted to a set of non-dimensional temperature response factors, called g-functions. The g-function allows the calculation of the temperature change at the borehole wall in response to a step heat input for a time step. Once the response of the borehole field to a single step heat pulse is represented with a g-function, the response to any arbitrary heat rejection/extraction

¹ This is in contrast to the practice in Sweden where the rock is mostly saturated granite and the borehole is not back-filled or grouted but allowed to fill with water.

profile can be determined by devolving the heat rejection/extraction profile into a series of step heat pulses, and superimposing the response to each step heat pulse.

This process is graphically demonstrated in Figure 1 for the four months of heat rejection.

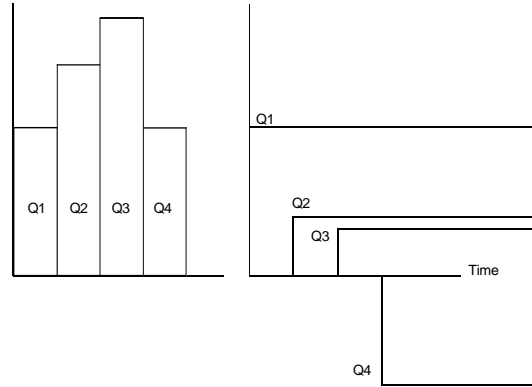

Fig. 1. Superposition of piece-wise linear step heat inputs in time. The step heat inputs Q2', Q3' and Q4' are superimposed in time on to the basic heat pulse Q1'.

The basic heat pulse from zero to Q1 is applied for the entire duration of the four months and is effective as Q1'=Q1. The subsequent pulses are superimposed as Q2'=Q2-Q1 effective for 3 months, Q3'=Q3-Q2 effective for 2 months and finally Q4'=Q4-Q3 effective for 1 month. Thus, the borehole wall temperature at any time can be determined by adding the responses of the four heat pulses. Mathematically, the superposition gives the borehole wall temperature at the end of the n th time step as:

$$T_{borehole} = T_{ground} + \sum_{i=1}^n \frac{(Q_i - Q_{i-1})}{2\pi k} g\left(\frac{t_n - t_{i-1}}{t_s}, \frac{r_b}{H}\right) \quad (1)$$

where:

t = time (s)

t_s = time scale = $H^2/9\alpha$

H = borehole depth (m)

k = ground thermal conductivity (W/m-K)

$T_{borehole}$ = average borehole temperature ($^{\circ}$ C)

T_{ground} = undisturbed ground temperature ($^{\circ}$ C)

Q = step heat rejection pulse (W/m)

r_b = borehole radius (m)

i = index to denote the end of a time step. (the end of the 1st hour or 2nd month etc.)

Figure 2 shows the temperature response factor curves (g-functions) plotted versus non-dimensional time for various multiple borehole configurations and compares them to the temperature response factor curve for a single borehole. The g-functions in Figure 2 correspond to borehole configurations with a fixed ratio of 0.1 between the borehole spacing and the borehole depth. The thermal interaction between the boreholes is stronger as the number of boreholes in the field is increased and as the time of operation increases.

The detailed numerical model used in developing the long time-step g-functions approximates the borehole as a line source of finite length, so that the borehole end effects can be considered. This approximation has the resultant problem that it is only valid for times greater than $5r_b^2/\alpha$. For a typical borehole, that might imply times from 3 to 6 hours. Furthermore, much of the data developed by Eskilson does not cover periods of less than a month. (For a heavy, saturated soil and a 76 m deep borehole, the g-function for the single borehole presented in Figure 3 is only applicable for times in excess of 60 days.)

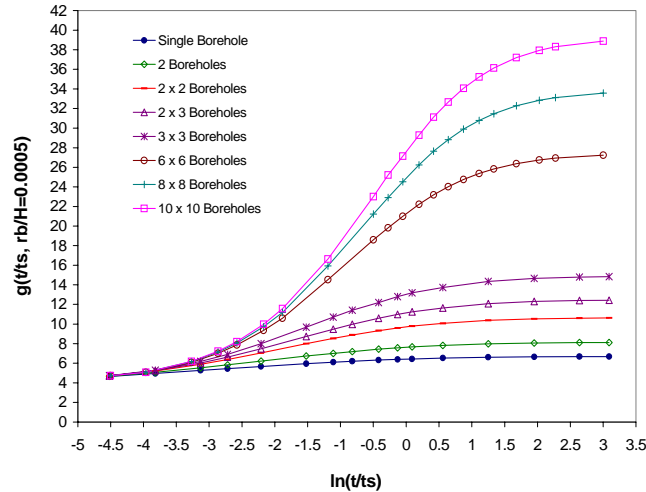

Fig. 2. Temperature response factors (g-functions) for various multiple borehole configurations compared to the temperature response curve for a single borehole.

2.1.2 Simulation Model

The simulation model described here has been presented, in considerable detail, by Yavuzturk and Spitler (1999). A brief description will be presented in this paper. The model is primarily aimed at applications in building energy analysis, where it is desirable to be able to predict system energy consumption on an hourly basis. The model was developed by extending Eskilson's g-functions down to times of less than one hour. Since the numerical model used by Eskilson to determine the g-functions is not suitable for short time steps, a more appropriate numerical model is used to estimate the temperature response of a single borehole for short duration of heat rejection/extraction pulses. For short duration heat pulses, heat transfer within the borehole and heat transfer outside the borehole, in the radial direction, are much more important than heat transfer in the axial direction. Hence, a two-dimensional, radial-angular, finite volume model has been developed. Complete details may be found in Yavuzturk, et al. (1999).

The numerical model is used to calculate the average fluid temperature in the borehole.. This is then adjusted by the borehole resistance to determine the average temperature at the borehole wall and then non-dimensionalized to form a g-function. The resulting short time-step g-function curve matches well at the boundary to the long time-step g-functions developed by Eskilson, as shown in Figure 3.

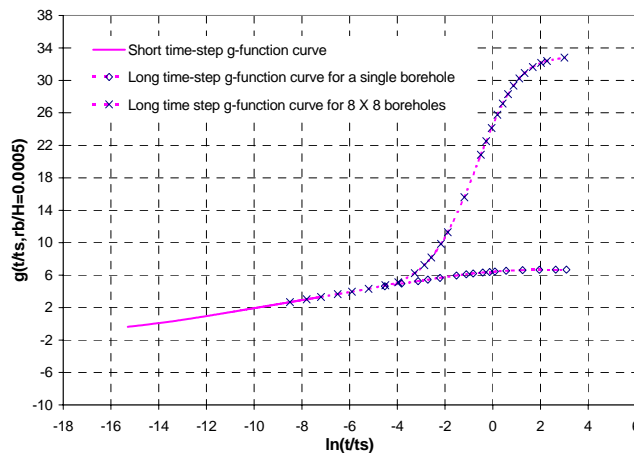

Fig. 3. Short time-step g-function curve as an extension of the long time-step g-functions plotted for a single borehole and an 8 X 8 borehole field.

The short and long time-step g -functions are converted to a continuous set of response factors. Although they may be applied directly with hourly time-steps, and hence, hourly heat rejection/extraction pulses, this becomes computationally intensive when multi-year simulations are performed. Since the importance of any given hour's response decreases as the hour gets further away in time, the loads are aggregated such that loads that occurred more than about one month previous to the current time are aggregated into 730 hour time blocks. Loads that occurred more recently are treated as hourly pulses. This approach gives significantly reduced computational time, while maintaining very good accuracy. The load aggregation procedure is given in more detail in the paper by Yavuzturk and Spitler (1999). Experimental validation of the model is described in detail by Yavuzturk and Spitler (2001).

2.2 Standing Column Well

Standing column wells are used for direct (i.e. open-loop) heat exchange with the earth. Figure 4 illustrates the configuration of a standing column well and the heat and mass transfer mechanisms. A numerical model has been developed for studying the performance of the standing column wells, which is composed of two parts: a nodal model of the borehole components and a finite volume model of the ground-water flow and heat transfer in the surrounding rock. This model allows the explicit treatment of the advective heat transfer induced by the ground-water flow (Rees, et al. 2003). More recent work (Deng 2004) has focused on development of a simpler, much faster model, suitable for use in energy analysis programs or design programs.

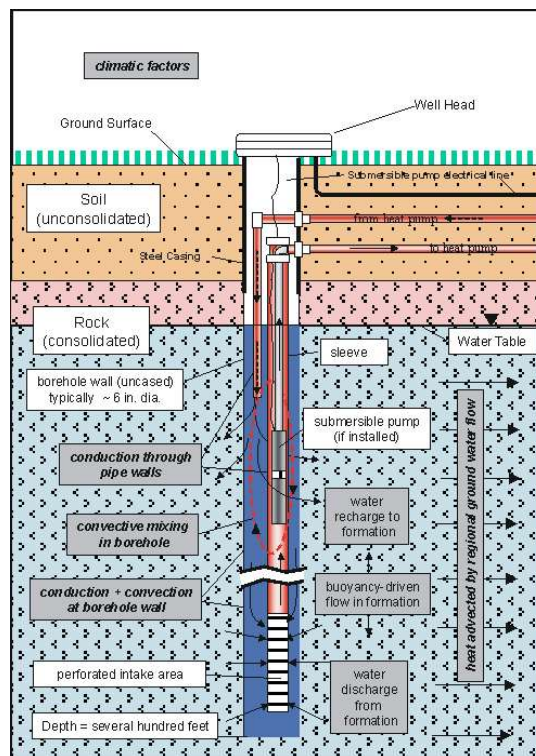

Fig. 4. Standing column well

2.3 Water Source Heat Pump

Jin and Spitler (2002) developed a parameter-estimation-based water-to-water heat pump model. This model used a thermodynamic analysis of the refrigeration cycle, simplified heat exchanger models, and a detailed model of the refrigerant reciprocating compressor. A second paper (Jin and Spitler 2003), presents some extensions, which included sub-models of scroll and rotary compressors, and a procedure for adapting

the model to use with anti-freeze solutions. The various parameters of the model were estimated from the manufacturers' catalog data by applying a multi-variable optimization algorithm. Jin (2002) described in detail the multi-variable optimization and the estimated parameters. The model's accuracy compared favorably to previously published deterministic and equation-fit type models. Jin (2002) also presented an analogous model for water-to-air heat pumps. Shenoy (2004) developed a simpler but faster equation-fit type model for water-to-air heat pumps.

2.4 Supplemental Heat Rejecters for Hybrid GSHP Systems

The cost of drilling the borehole field for a ground-source heat pump system, although it depends strongly on the local geological conditions, can often be a substantial portion of the system capital cost. This is most likely in buildings where the demand is predominantly for cooling. In situations like this and where the thermal conductivity of the ground is low or drilling conditions are poor, the cost of the borehole field may make a ground-source system uneconomical. However, a compromise between first cost and energy efficiency may be possible by using a smaller borehole field and adding a supplemental heat rejecter into the heat pump water loop. Such systems have been termed 'hybrid' ground-source heat pump systems.

A number of different types of heat rejecters have been suggested for inclusion in the water loop of hybrid systems, including cooling tower, shallow pond with heat exchanger, and hydronically heated pavement or bridge deck. The shallow pond model has been developed by Chiasson, et al. (2000a), which accounts for several natural heat transfer mechanisms within a surface water body plus convective heat transfer due to a closed-loop heat exchanger. Chiasson, et al. (2000b) also developed a finite difference model for hydronically heated pavement or bridge deck. This model has been further developed to be able to model the snow melting process taking place on the top surface of the slab (Liu, et al. 2003). These models have been validated using data from a number of experimental supplemental heat rejecters at Oklahoma State University.

3 SIMULATION APPLICATIONS IN DESIGN OF VERTICAL GLHE

Design of closed-loop ground heat exchangers is rather different from air-coupled heat exchangers in that the primary heat transfer mechanism is conduction rather than convection (unless the ground-water flow is high). The most significant implication of this is that, depending on the balance between extraction and rejection of heat from and to the ground, the ground temperature in the neighborhood of the heat exchanger may rise or fall over the life of the system, particularly when the annual heat rejection/extraction is significantly imbalanced. In such cases the ground temperature may rise (or fall) over a number of years, resulting in a decrease in the performance of the heat pump as the entering fluid temperature to the heat pump rises (or falls). A design goal must therefore be to control the change in the temperature within acceptable limits over the life of the system.

The net heating or cooling of the ground over each season clearly depends on the accumulated heat rejection and extraction, and therefore on the building loads throughout the whole year. The design methodology has to be based then on the building loads calculated throughout the whole year, not just the peak heating and cooling loads. Hence more information is required regarding the building loads than for sizing of a conventional system.

Design methodologies available for residential ground loop heat exchangers have been reviewed by Cane and Forgas (1991). Yavuzturk (1999) provides a more up-to-date review of all available methodologies. Kavanaugh (1995) described a design procedure commonly used in the United States.

A design methodology that utilizes the simulation procedures described in Section 2 is covered in detail by Spitler (2000). A very short summary is that the simulation methodology described in Section 2 is

utilized with two time steps – a monthly time step, and a shorter peak pulse type time step. However, the peak heat extraction or rejection pulse has been modeled with a simpler analytical approximation.

The design methodology has been implemented in a commercially available software package (Spitler 1999, 2000). This program requires that the user provide the following information:

- monthly heating and cooling loads on the heat pump or heat pumps, typically determined by a building energy analysis program;
- monthly peak heating and cooling loads, again on the heat pumps and typically determined by a building energy analysis program;
- information about the heat pump or heat pumps, from which the relationship between the entering fluid temperature to the heat pump and the heat rejected to the ground for a given cooling load and the heat extracted from the ground for a given heating load can be determined;
- thermal properties of the ground;
- geometric configuration of the ground loop heat exchanger;
- borehole diameter, U-tube diameter, grout thermal properties;
- thermal properties of the working fluid.

Assuming a given borehole depth, and the above information, the average fluid temperature in the GLHE at the end of each month, the entering fluid temperature at the end of each month, and the actual heat rejection rate for each month are determined simultaneously. Then, the responses to the peak pulses are determined for each month, and the resulting peak entering fluid temperatures to the heat pump(s) for each month are determined.

The program also has a sizing mode where the minimum borehole depth that will meet user-specified minimum and maximum peak temperatures is determined by searching with the simulation until the depth is found that is constrained by either the minimum or maximum peak entering fluid temperature.

4 SIMULATION APPLICATIONS IN GSHP SYSTEM INVESTIGATIONS

By coupling the component models in modular simulation environments such as TRNSYS and HVACSIM+, the performance of a specific GSHP system can be simulated, and the effects of component sizes, control strategies, etc. can be evaluated. Hourly or shorter time steps may be used so that diurnal variations in loop temperature, time-of-day rates, etc. may be accounted for. Ultimately, it is anticipated that this approach will be used to design GSHP systems. To date, it has been primarily used for feasibility studies and parametric investigations. Three types of sample applications are discussed below.

4.1 Hybrid GSHP Systems

Hybrid GSHP systems utilize supplemental heat rejecters to balance the annual heat rejection to the ground and the annual heat extraction from it. With the supplemental heat rejecter(s), the size of the ground loop heat exchanger may be reduced significantly.

Perhaps the most obvious candidate for a supplemental heat rejecter in a hybrid system would be a conventional open-circuit cooling tower. Yavuzturk and Spitler (2000) investigated a number of operating strategies for an HGSHP system with a cooling tower, using the simulation methodology described above. One method investigated for controlling the cooling tower was to switch on the cooling tower only when a certain heat pump entering water temperature was exceeded. It was found that this simple strategy does not result in the cooling tower operating during the most advantageous weather conditions. A second strategy studied involved operating the cooling tower on a predetermined schedule. This also results in wasting some pump and fan energy by running the tower when little heat transfer can be obtained. The most effective strategy was found to be one where the tower was controlled by the difference between the heat pump

entering fluid temperature and the wet bulb temperature. This allows the cooling tower to be used under the most advantageous weather conditions (where the potential is greatest for heat rejection). For the climate conditions considered, this control strategy yields the lowest life cycle cost.

Another possible supplemental heat rejecter is a pavement heat exchanger, consisting of pipes buried just below a road or other paved surface. In a recent study (Khan et al. 2003), it was shown through simulation how a parking area of a medium size office building could be used as a supplemental heat rejecter to reduce the length of the boreholes. For the particular case examined here, the addition of a 36 m² heated parking lot allowed a reduction in size of the GLHE from 16 to 9 boreholes, each 73 m deep. With the addition of the parking lot heating system, operating costs decreased slightly and the system also performed some snow melting, reducing the number of hours that the parking lot would be snow-covered without other intervention from 175 to 115.

Shallow ponds have also been suggested as possible heat rejecters for use in hybrid ground-source heat pump systems. Where ponds are required for either landscaping, irrigation or flood control purposes it is relatively simple and cost effective to introduce additional pipe coils at the bottom of the pond connected into the loop with the borehole field. A parametric study (Ramamoorthy et al. 2001) has shown that incorporating a shallow pond into the GSHP system could significantly decrease the size of the GLHE.

Hybrid GSHP systems that use solar thermal collectors for diurnal and seasonal thermal underground energy storage have been studied (Chiasson and Yavuzturk 2003) for applications in cold climates. The study models an actual school building with typical meteorological year weather data for a number of cities with varying climates and insolation. The results of the study have shown that hybrid solar GSHP systems are a viable choice for space conditioning of heating dominated buildings.

4.2 Direct Cooling GSHP System

One form of GSHP system that appears promising for UK application is a system where building heating is provided via one or more water-to-water heat pumps coupled to the space heating system. Building cooling may be provided by circulating water directly between the ground loop heat exchanger and chilled ceilings or beams. In this system, the heat extracted from the ground for heating is replaced during the cooling season, and cooling is provided at almost no cost. Spitler and Underwood (2003) presented a simulation study of this application for a five-story office building in Newcastle. Compared to a conventional system with condensing gas boilers and vapor compression refrigeration, energy consumption was 44% lower and carbon emissions were 57% lower for this system.

4.3 GSHP Based Bridge Snow Melting System

A GSHP-based bridge heating system has been proposed as an alternative means to prevent ice formation and snow accumulation on bridge surfaces. Such a system can potentially offer improved road safety and increased bridge deck life. A number of heat sources have been proposed for such systems, including heat pipes, natural gas boilers and electric cables. GSHP systems and hydronic-heating offer improved energy efficiency over other systems. Such systems consist of hydronic tubing embedded in the bridge deck with hot water circulated from a number of water-to-water heat pumps that, in turn, extract heat through the ground via vertical U-tube borehole heat exchangers, as shown in Figure 6. Oklahoma State University has recently conducted a research project on this geothermal bridge deck technology.

Application of geothermal bridge deck snow melting technology has been discouraged by higher initial costs, but also lack of reliable design procedures, modeling methods and software tools.

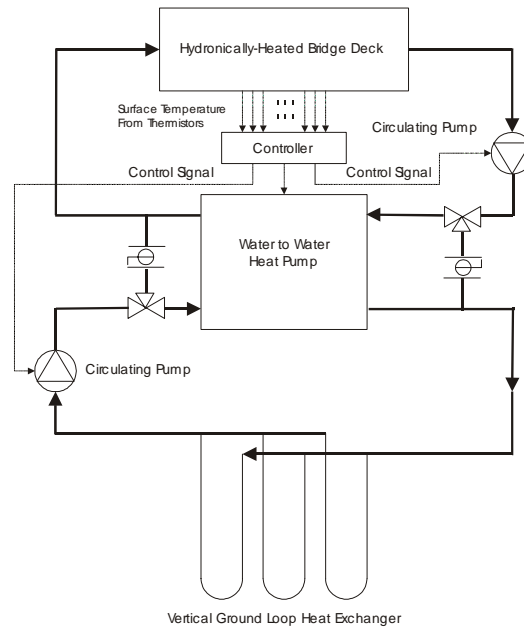

Fig. 6. Schematic diagram of a GSHP based bridge snow melting system

A simulation tool for the GSHP based bridge snow melting system has been developed by incorporating the appropriate component models under the modular simulation environment of HVACSIM+ (Liu, et al. 2003). The simulation results have been validated with operating data and corresponding weather data from a medium scale experimental bridge snow melting system that employed a GSHP system as heat source. The validation results show the ability of this simulation approach to successfully predict the performance of the system under a wide range of operating and weather conditions. With this simulation tool, further research is ongoing, which includes optimizing the control strategies of “recharging” the ground in summer with the heat absorbed by the bridge deck, and developing a simulation based procedure to facilitate the design of such GSHP based bridge snow melting systems.

5 OPTIMIZATION

One natural extension to the simulation work described here is optimization – e.g., automatically adjusting the design parameters to minimize life cycle cost. Since the design of a ground source heat pump system has many degrees of freedom, and the interaction between the design variables is relatively complex, automated optimization is a potentially useful tool for GSHP system design. Some preliminary work in this area has been presented by Khan and Spitler (2004) and Khan (2004). The first reference presents a study of residential systems, where a few variables are optimized at any one time. The detailed system simulation accounts for the effects of antifreeze concentration, entering fluid temperature and flow rate on heat pump capacity. Mass flow rate in the system was solved for every time step and varied with the fluid transport properties, which depended on temperature and antifreeze concentration. Life cycle cost was chosen as the objective function. A penalty function approach was used to prevent freezing in the system and/or unmet loads. Optimizing a few variables at a time allowed the determination, for example, of optimal GLHE size and antifreeze concentration, if all other variables were held constant.

Khan (2004) reported on an attempt to simultaneously optimize all variables using both a particle swarm optimization algorithm and the Hooke-Jeeves algorithm. Ultimately, these attempts met with limited success – in order to be confident that the constraints on freezing and unmet loads were really and truly met, it was necessary to perform a multi-year (e.g. twenty-year) simulation; that long of a simulation combined with a large number of objective function evaluations caused the optimization to become intractable. Fu-

ture work with larger time steps in the early years may facilitate optimization, but no conclusion has yet been reached as to the potential for reductions in life cycle cost due to optimal design.

6 CONCLUSIONS

Ground-source heat pump technology has developed over the last two decades to a point where systems are being routinely installed on small and medium-sized projects in many parts of the U.S. Use of the ground as a heat sink/source rather than the air is advantageous, in terms of energy savings, throughout the heating and cooling season.

Models of the main components of the GSHP system are now available. The long-term and short-term performance of the ground-loop heat exchanger can be predicted. The performance of the standing column well can be predicted with a numerical model. In addition, models of water source heat pump and different forms of supplemental heat rejecter have also been developed.

By utilizing these component models in a modular simulation environment, a number of previously impractical simulations have been performed. These simulations have been applied in the design a variety of hybrid ground source heat pump systems. Parametric studies performed with these simulations have led to new insights about system design.

A procedure for the design of vertical closed-loop ground heat exchangers has been developed from the earlier work of Eskilson. The procedure takes account of the cumulative effect of the building loads rejected to and extracted from the ground loop on its long-term performance. With this procedure, the required length of the boreholes can be calculated to maintain the heat pump entering fluid temperature within its design limits over the life of the project.

Preliminary attempts at automated optimization have yielded only modest successes. Additional work in the near future should, at least, indicate more clearly what potential savings in life cycle cost might be achieved with optimal design procedures.

REFERENCES

- Cane, R L D. and D.A. Forgas. 1991. Modeling of ground-source heat pump performance. ASHRAE Transactions. 97(1):909-925.
- Cane, R.L.D and Clemes, S.B. 1995. A Comparison of Measured and Predicted Performance of a Ground-source Heat Pump System in a Large Building. ASHRAE Transactions, 101(2):1081-1087.
- Cane, R.L.D., A. Morrison and C.J. Ireland. 1998. Maintenance and Service Costs of Commercial Building Ground-source Heat Pump Systems. ASHRAE Transactions, 104(2): 699-706.
- Chiasson, A.D., J.D. Spitler, S.J. Rees, M.D. Smith. 2000a. A Model for Simulating the Performance of a Pavement Heating System as a Supplemental Heat Rejecter with Closed-loop Ground-Source Heat Pump Systems. ASME Journal of Solar Energy Engineering. November 2000. 122:183-191.
- Chiasson, A.D., J.D. Spitler, S.J. Rees, M.D. Smith. 2000b. A Model for Simulating the Performance of a Shallow Pond as a Supplemental Heat Rejecter with Closed-loop Ground-Source Heat Pump Systems. ASHRAE Transactions. 106(2):107-121.
- Chiasson, A. D., C. Yavuzturk. 2003. Assessment of the Viability of Hybrid Geothermal Heat Pump Systems with Solar Thermal Collector. ASHRAE Transactions 109(2):487-500.
- Deng, Z. 2004. Modeling of Standing Column Wells in Ground Source Heat Pump Systems. Ph.D. dissertation, Oklahoma State University, Stillwater, OK.
(<http://www.hvac.okstate.edu/pdfs/Deng%20Thesis.pdf>)

- Dinse, D.R. 1998. Geothermal System for School. *ASHRAE Journal*, 40(5): 52-54.
- EPRI. 1989. (Bose, J.E., Editor) Soil and Rock Classification for the Design of Ground-Coupled Heat Pump Systems—Field Manual. Electric Power Research Institute Special Report, EPRI CU-6600.
- Eskilson, P. 1987. Thermal Analysis of Heat Extraction Boreholes. Doctoral Thesis, University of Lund, Department of Mathematical Physics. Lund, Sweden.
- GHPC, 2003a. Commercial: Schools. Geothermal Heat Pump Consortium. (<http://www.geoexchange.org/commercial/schools.htm>).
- GHPC, 2003b. Residential: Case Studies. Geothermal Heat Pump Consortium. (http://www.geoexchange.org/residential/res_case.htm).
- GHPC, 2003c. Commercial: Case Studies. Geothermal Heat Pump Consortium. (http://www.geoexchange.org/commercial/com_case.htm).
- Jin, H. 2002. Parameter Estimation Based Models of Water Source Heat Pumps. Ph. D. Thesis: Oklahoma State University. Stillwater, Oklahoma.
- Jin, H. and J.D. Spitler. 2002. A Parameter Estimation Based Model of Water-To-Water Heat Pumps for use in Energy Calculation Programs. *ASHRAE Transactions*. 108(1): 3-17.
- Jin, H. and J.D. Spitler. 2003. Parameter Estimation Based Model of Water-to-Water Heat Pumps with Scroll Compressors and Water/Glycol Solutions. *Building Services Engineering Research and Technology*. 24(3):203-219.
- Kavanaugh S., 1995. A design method for commercial ground-coupled heat pumps. *ASHRAE Transactions*. 101(2):1088-1094.
- Khan, M. 2004. Modeling, Simulation and Optimization of Ground Source Heat Pump Systems. M.S. Thesis, Oklahoma State University, Stillwater, OK. (http://www.hvac.okstate.edu/pdfs/Haider_Khan_thesis.pdf)
- Khan, M.H., A. Varanasi, J.D. Spitler, D.E. Fisher, R.D. Delahoussaye. 2003. Hybrid Ground Source Heat Pump System Simulation Using Visual Modeling Tool For Hvacsim+. *Proceedings of Building Simulation 2003* pp. 641-648. Eindhoven, Netherlands, August 11-14, 2003. (http://www.hvac.okstate.edu/pdfs/Khan_Varanasi_Spitler_Fisher_Delahoussaye_2003.pdf)
- Khan, M.H., J.D. Spitler. 2004. Performance Analysis of a Residential Ground Source Heat Pump System with Antifreeze Solution. *Proceedings of SimBuild 2004*, Boulder, Colorado August 4-6.
- Liu, X., S.J. Rees, J.D. Spitler. 2003. Simulation of a Geothermal Bridge Deck Snow melting System and Experimental Validation. *Proceedings of the Transportation Research Board 82nd Annual Meeting*, Washington, D.C. January 12-16, 2003.
- Lund, J., B. Sanner, L. Rybach, R. Curtis and G. Hellström. 2004. Geothermal (Ground-Source) Heat Pumps – A World Overview. *Geo-Heat Center Bulletin*, September.
- Park, C., D.E. Clark, and G.E. Kelly. 1985. An Overview of HVACSIM+, a Dynamic Building/HVAC/Control Systems Simulation Program. *Building Energy Simulation Conference*, Seattle, Washington. August 21-22, 1985.
- Ramamoorthy, M., H. Jin, A. Chiasson, J.D. Spitler. 2001. Optimal Sizing of Hybrid Ground-Source Heat Pump Systems that use a Cooling Pond as a Supplemental Heat Rejecter – A System Simulation Approach. *ASHRAE Transactions*. 107(1):26-38.
- Rees, S.J., J.D. Spitler, Z. Deng, C.D. Orio and C.N. Johnson. 2003. A Study Of Geothermal Heat Pump And Standing Column Well Performance. *ASHRAE Transactions* 109(2), In press.
- SEL. 1996. TRNSYS Manual - a Transient Simulation Program. Madison: Solar Engineering Laboratory, University of Wisconsin.
- Shenoy, A. 2004. Simulation, Modeling and Analysis of a Water to Air Heat Pump. M.S. Thesis, Oklahoma State University, Stillwater, OK.

- Spitler, J.D. and C. Underwood. 2003. UK Application of Direct Cooling Ground Source Heat Pump Systems. Proceedings of ASHRAE-CIBSE Conference, Edinburgh, Scotland, September 24-26, 2003. (http://www.hvac.okstate.edu/pdfs/UK_Application_of_Direct_Cooling_GSHP_w_authors.pdf)
- Spitler, J.D. 1999. GLHEPRO 3.0 for Windows Users Guide. School of Mechanical and Aerospace Engineering, Oklahoma State University.
- Spitler, J.D. 2000. GLHEPRO -- A Design Tool For Commercial Building Ground Loop Heat Exchangers. Proceedings of the Fourth International Heat Pumps in Cold Climates Conference, Aylmer, Québec. August 17-18, 2000. (<http://www.hvac.okstate.edu>)
- Yavuzturk, C., J.D. Spitler. 1999. A Short Time Step Response Factor Model for Vertical Ground Loop Heat Exchangers. ASHRAE Transactions. 105(2):475-485.
- Yavuzturk, C. 1999. Modeling of Vertical Ground Loop Heat Exchangers for Ground Source Heat Pump Systems. Ph.D. Thesis, School of Mechanical and Aerospace Engineering. Oklahoma State University. (http://www.mae.okstate.edu/Faculty/spitler/pdfs/Yavuzturk_thesis.pdf)
- Yavuzturk, C., J. D. Spitler, S. J. Rees. 1999. A Transient two-dimensional Finite Volume Model for the Simulation of Vertical U-Tube Ground Heat Exchangers. ASHRAE Transactions. 105(2):465-474.
- Yavuzturk, C. and J. D. Spitler, 2000. Comparative Study to Investigate Operating and Control Strategies for Hybrid Ground Source Heat Pump Systems Using A Short Time-step Simulation Model. ASHRAE Transactions. 106(2):192-209.
- Yavuzturk, C., J.D. Spitler. 2001. Field Validation of a Short Time-Step Model for Vertical Ground Loop Heat Exchangers. ASHRAE Transactions. 107(1):617-625.