



Greek Solar Thermal Market

Market Development and Tools
Awareness, International Trade

ECONOMOU APOSTOLOS
Executive Secretary GSIA



Greek Solar Industry Association



ΕΝΩΣΗ ΒΙΟΜΗΧΑΝΙΩΝ ΗΛΙΑΚΗΣ ΕΝΕΡΓΕΙΑΣ

Dimosthenous Str. 267, 17674 Athens, Greece.

Tel. +30210 9416057 Fax 9409119

www.ebhe.gr

Email: info@ebhe.gr

GSIA Members

Est.1979

Alpak

SAMMLER®

THERMOHELLAS

FYROGENIS

C
Aloria s.p.a.

STEHellas

ΗΛΙΑΚΑ ΣΥΣΤΗΜΑΤΑ
ΔΗΜΑΣ

HOWAT

FOCO®

ΗΛΙΟΘΕΡΜΟ

MD MELPO

**NOBEL
XYLINAKIS**

MALTEZOS

ΣΗΕ

Intersolar®

ROMINA

SIELINE

HELIOAKMI



Products in Greece

- Solar water heater Thermosiphonic 95%
 - Private customers
- Central pump systems
 - Mainly professional customers
 - Hot water for hotels (95%), hospitals, etc
 - Process hot water
 - Solar cooling

Domestic Pump System



Thermosiphonic Water Heater

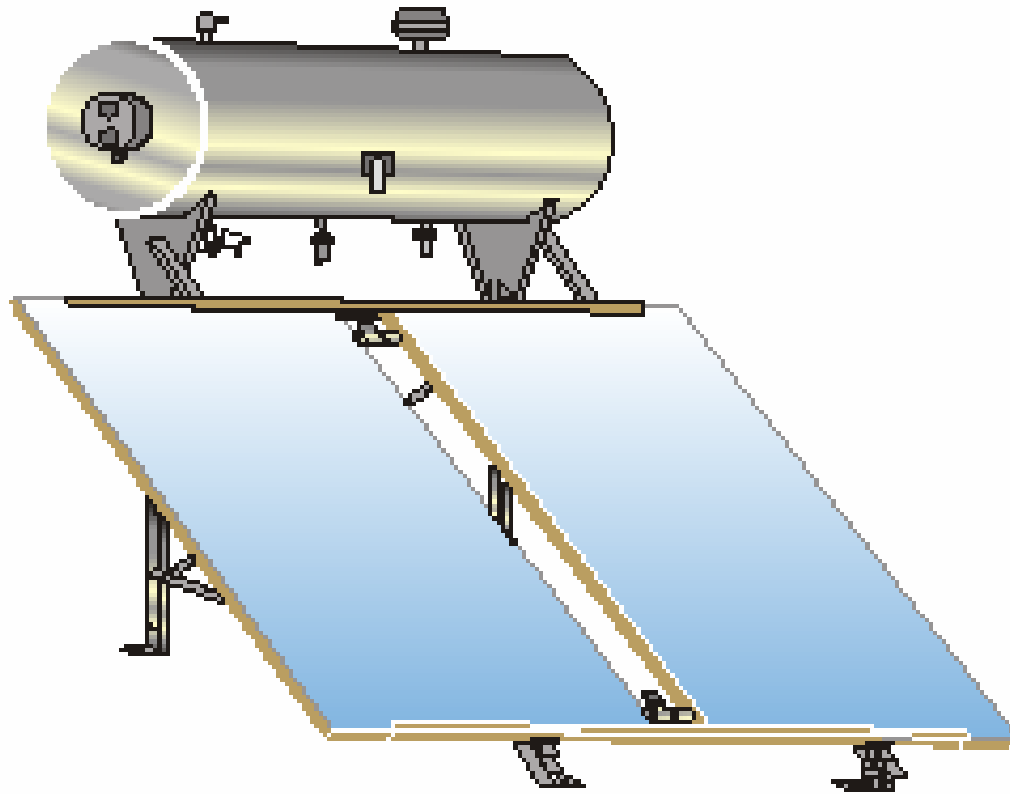



Thermosiphonic Water Heater

- Requires flat roof or integration on roof or acceptance by customer
- Inexpensive installation
- Simple installation
 - No mistakes by installers
 - No negative influence on customers by installers

Sales

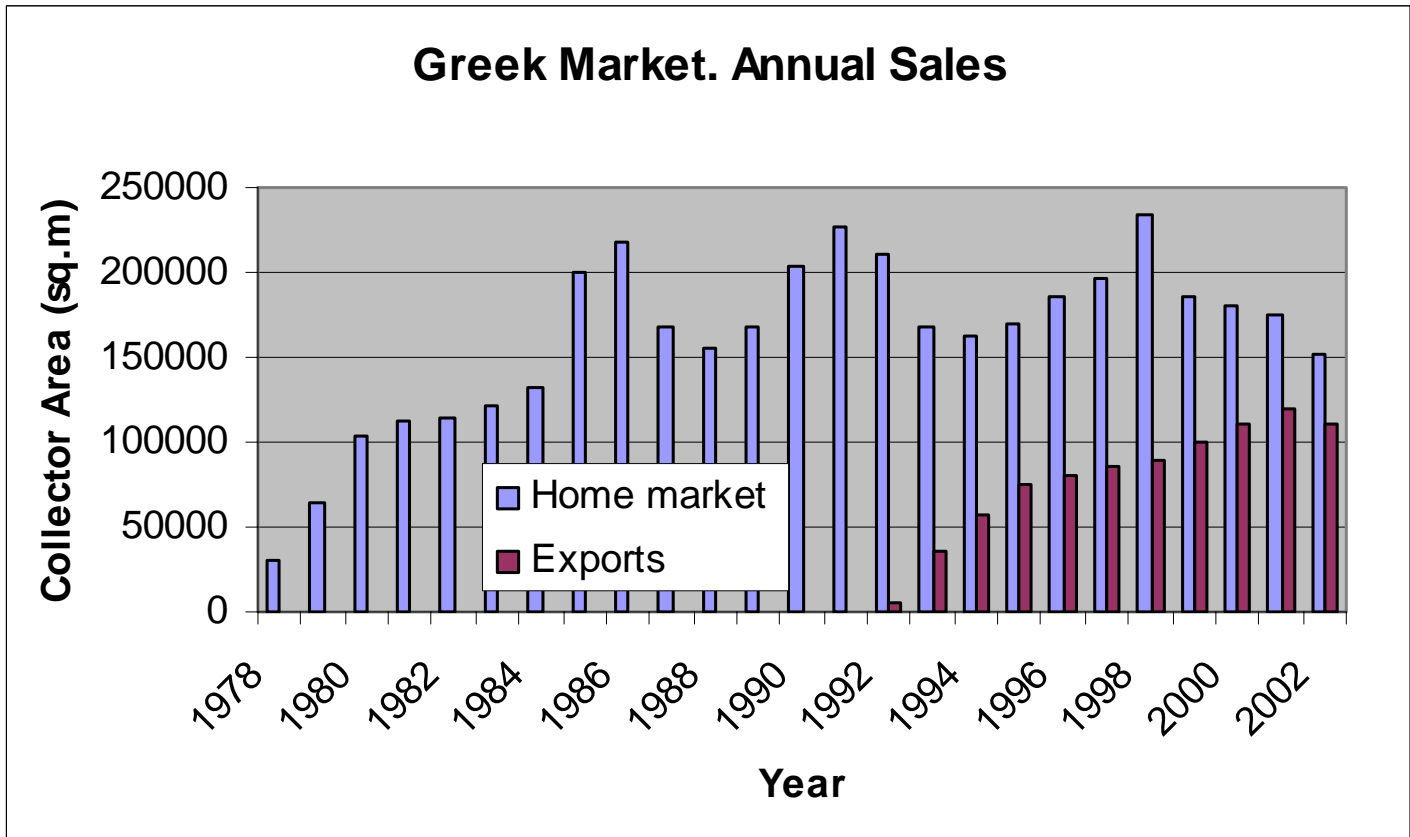

Medium Term Trend

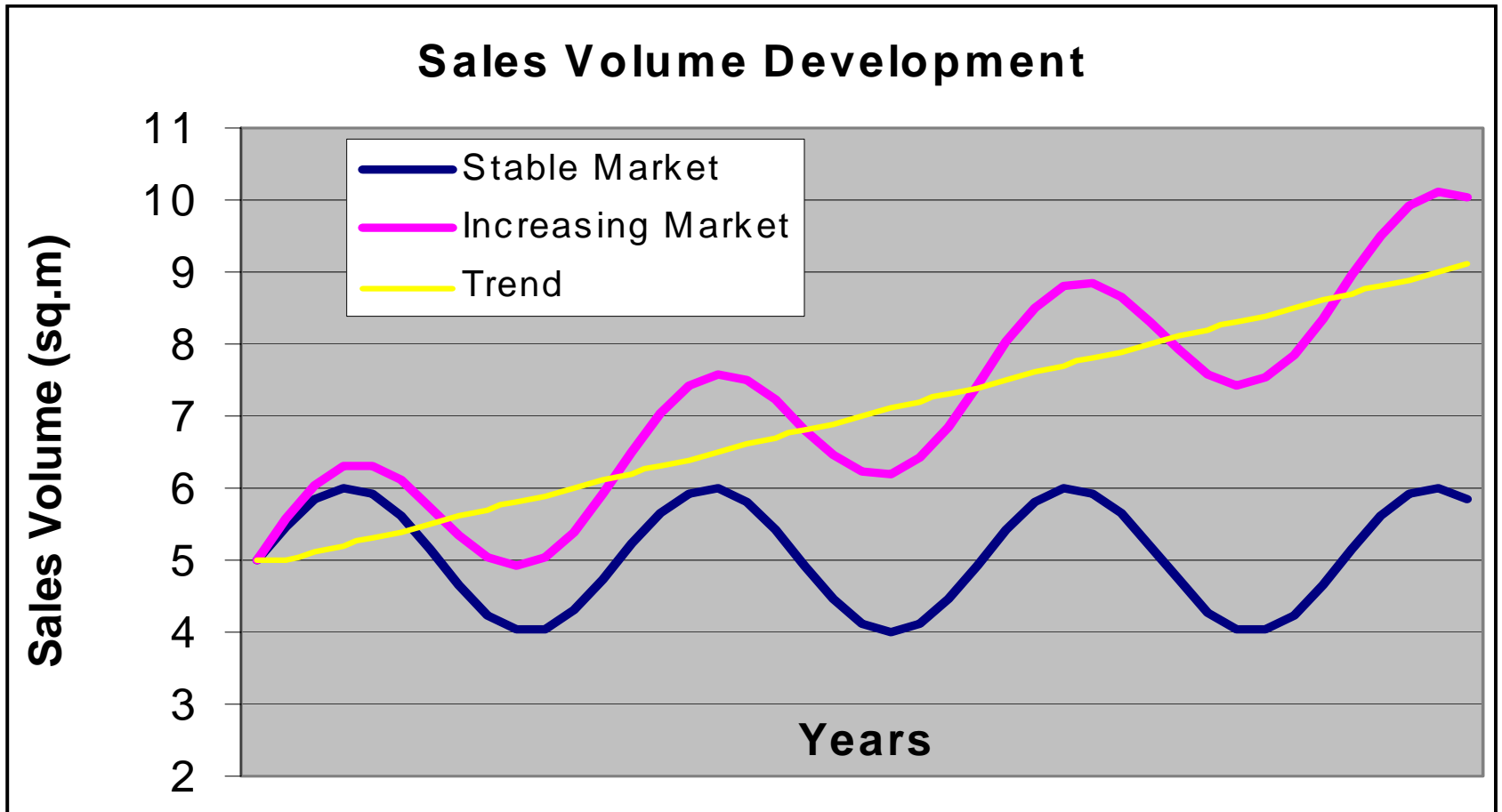



Market Structure Now

Manufacturer

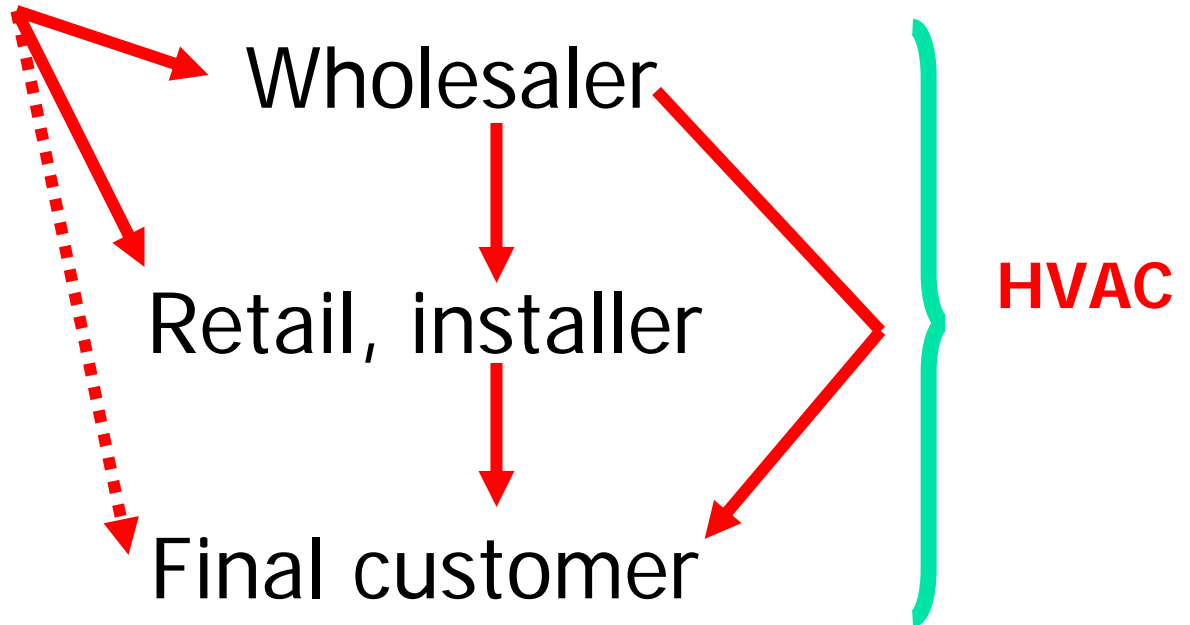



Initial Market Structure

Manufacturer

Manufacturer

Wholesaler (solar only)

Final customer

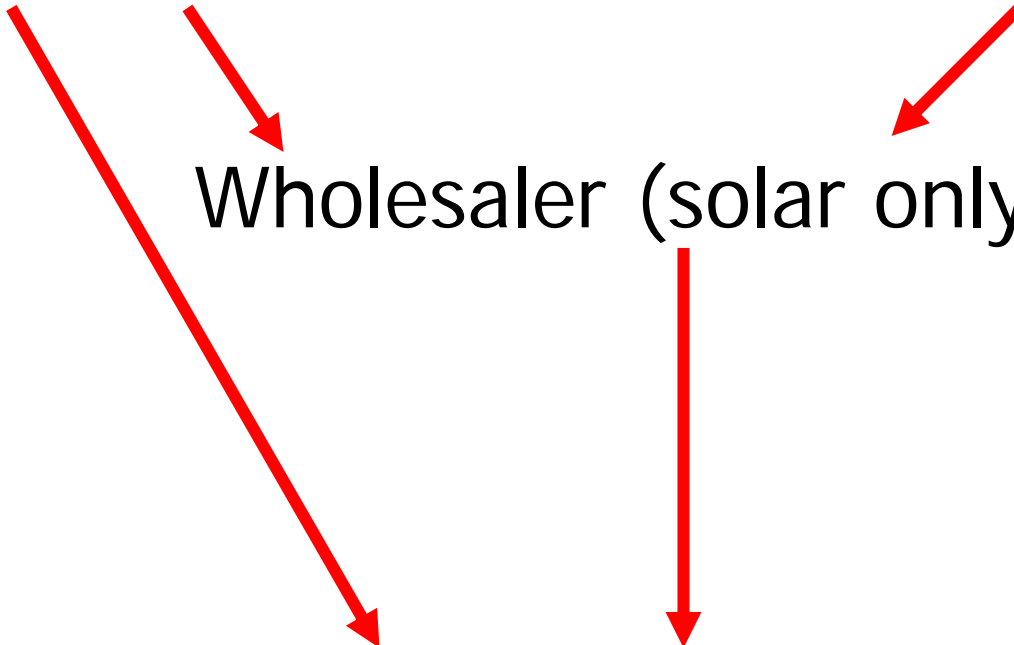



Advertising/Awareness Campaigns

- 1979-1981 Industry, State
(benefits of solar energy)
- 1984-1985 Industry, State
(economy)
- 1995 Public Power Corporation



Awareness for Solar

- **Hot water** : Complete
- **Process heat** : not satisfactory
- **Space heating** : only 'futuristic'
- **Solar cooling** : 'startup phase'
- Other in project level (drying, etc.)



International Trade

Positive

- European safety requirements CE mark
- European standards

- Solar Keymark



Negative

- National & regional requirements



Exported Products

- **Solar water heaters** (Mediterranean, 37 countries all over)
- **Solar collectors** (Europe, mainly central)
- **Small solar tanks** - suitable for thermosiphonic systems- (Mediterranean)
- **Absorbers, etc.**- (Eastern Europe)



Key to Enlarge Solar Market

Simple and long term rules for subsidies