



Greek Solar Thermal Market

Market Development and Tools
Awareness, International Trade

Dr. Iordanis Paradissiadis
Member Greek Solar Industry Association



Greek Solar Industry Association



Acharnon Str. 315, GR-11145 Athens

www.ebhe.gr

Email: info@ebhe.gr

GSIA Members

Est.1979

Si ma
Solar Systems

Calpak

DIANA
СOЛ AД KEATECЕ IMHICTOY

MALTEZOS

SIELINE

PAPAEMMANOUEL-S.A.

Solar Flame
Premium
Solar Systems

SAMMLER

ΣΗΕ

ΗΛΙΟΘΕΡΜΟ

ΗΛΙΟΘΕΡΜΑ-ΠΟΛΥΚΟΥΖΙΝΑ
Kipriotakis
2810-381300

HELIOAKMI

EBHA
EBIL

THERMOHELLAS

MD MELPO

InterSolar

SONNE
Aktion

HELIONAL
Solar Systems

HOWAT

ΗΛΙΑΚΑ ΣΥΣΤΗΜΑΤΑ
ΔΗΜΑΣ

NOBEL
XYLINAKIS

ROMINA

STIBETHERM



Products in Greece

- Solar water heater Thermosiphonic 95%
 - Private customers
- Central pump systems
 - Mainly professional customers
 - Hot water for hotels (95%), hospitals, etc
 - Process hot water
 - Solar cooling

Domestic Pump System

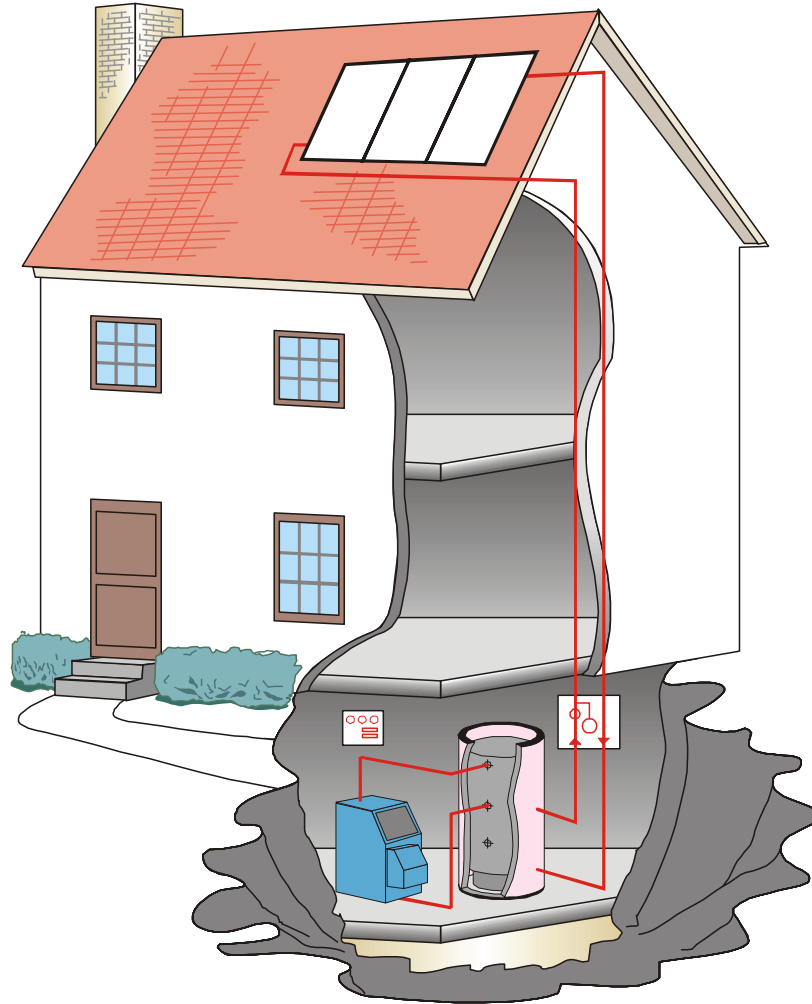

Thermosiphonic Water Heater

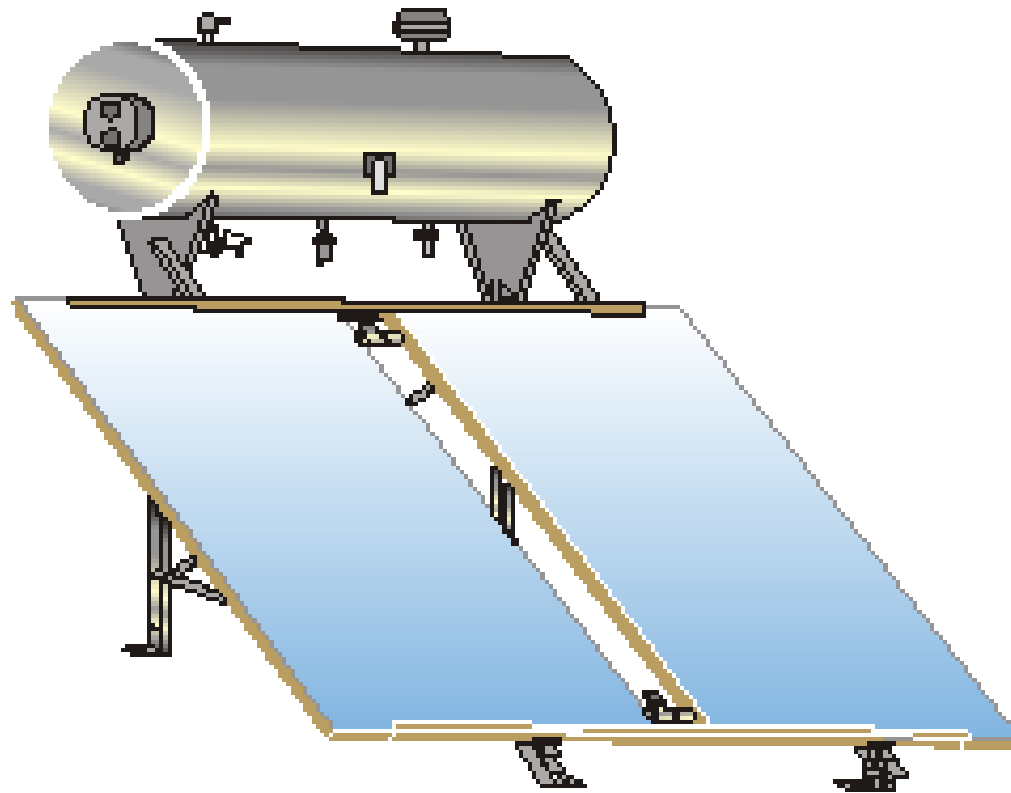



Thermosiphonic Water Heater

- Inexpensive installation
- Simple installation
 - No mistakes by installers
 - No negative influence on customers by installers

Sales



Total sales Greek Industry

■ Sales of solar collectors (m²) in the Greek Market ■ Export

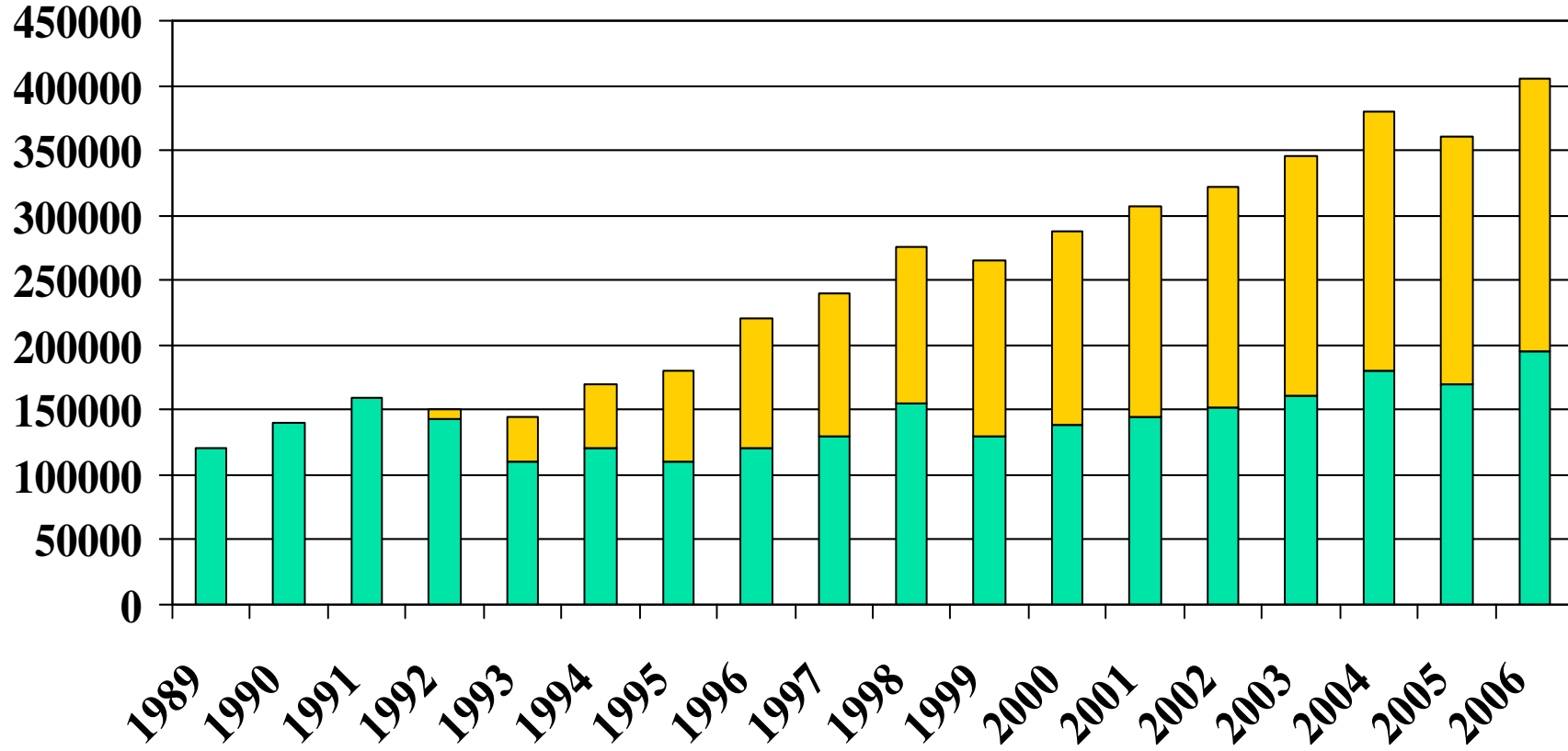



GREEK FIGURES - 2008

Installed collector area

- 3.550.000 m² or 2.485.000 kW

Yearly savings

- 1.952.500 MWh
- 2.000.000 tn CO₂

- 3.300 jobs
- 250.000.000 Euro



Market Structure Now

Manufacturer

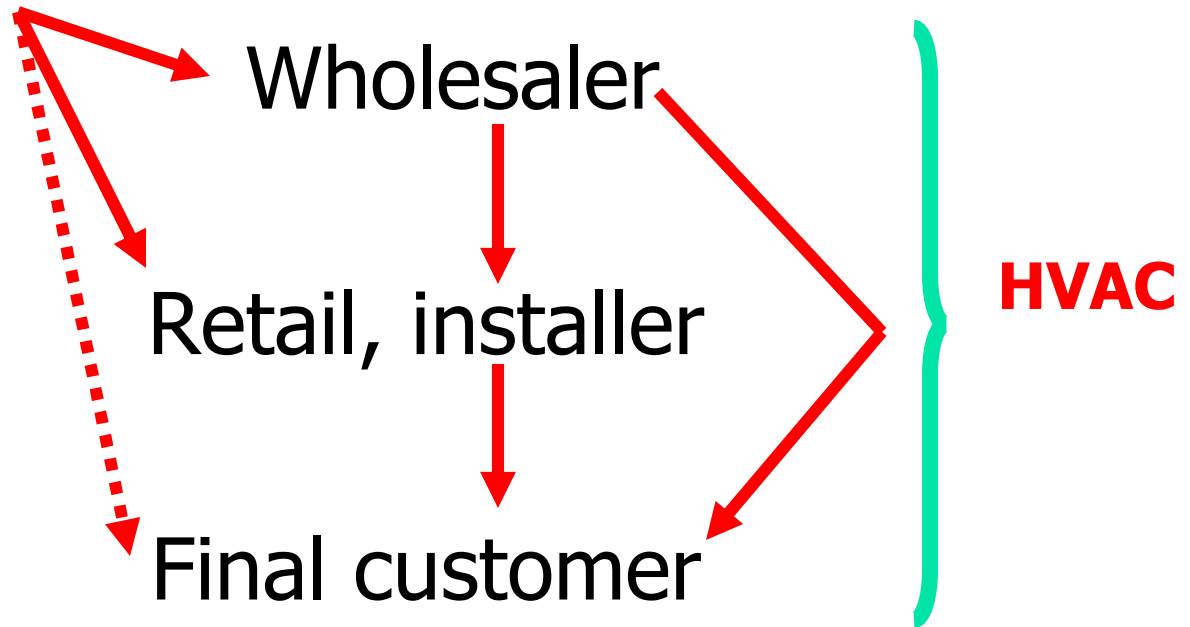



Initial Market Structure

Manufacturer

Manufacturer

Wholesaler (solar only)

Final customer

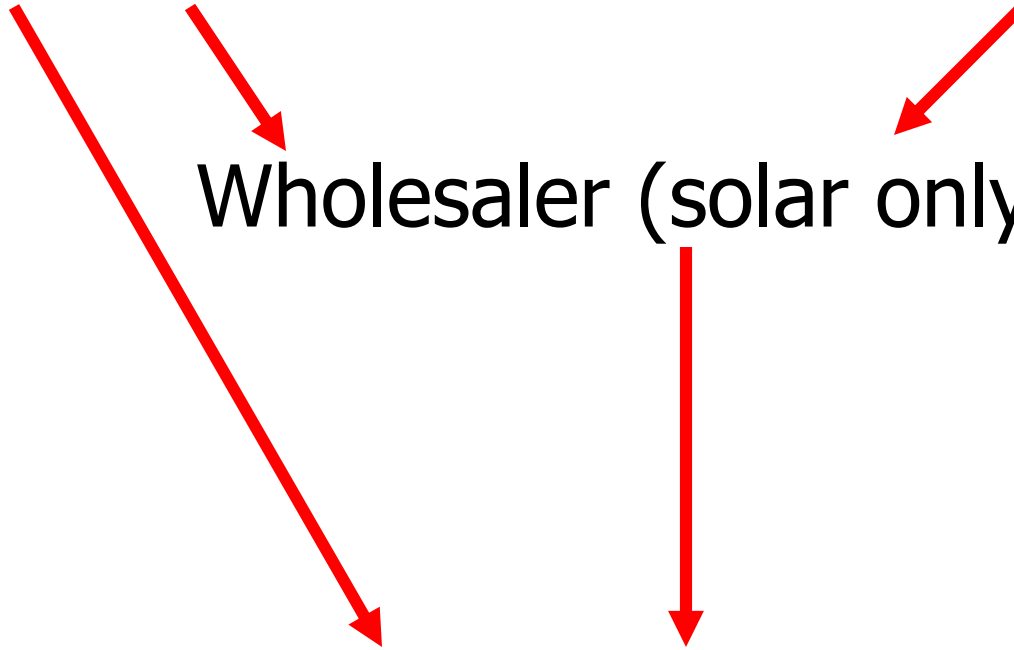



Advertising/Awareness Campaigns

- 1979-1981 Industry, State
(benefits of solar energy)
- 1984-1985 Industry, State
(economy)
- 1995 Public Power Corporation



Awareness for Solar

- **Hot water** : Complete
- **Process heat** : not satisfactory
- **Space heating** : only 'futuristic'
- **Solar cooling** : 'startup phase'
- Other in project level (drying, etc.)



Association International Activities

- Initiated ESTIF in 1991
- Initiated European Standards Committee in 1992 (CEN/TC312)
- Provided since Chairman and Secretary for CEN/TC312
- Provided subcommittee convenorship for ISO standards



International Trade

Positive

- European directives
- European standards

- Solar Keymark



Negative

- National & regional requirements



Exported Products

- **Solar water heaters** (Mediterranean, 37 countries all over)
- **Solar collectors** (Europe)
- **Small solar tanks** - suitable for thermosiphonic systems- (Mediterranean)
- **Absorbers, etc.-** (Europe)



Key to Enlarge Solar Market

Simple and long term rules for subsidies