

Solar Combi Systems

TranSolar Workshop
Slovenia

Dimitrios Chasapis

R.E.S. Systems Technology Engineer

ΚΑΠΕ Τομέας Θερμικών Ηλιακών Συστημάτων

Solar Thermal Collectors

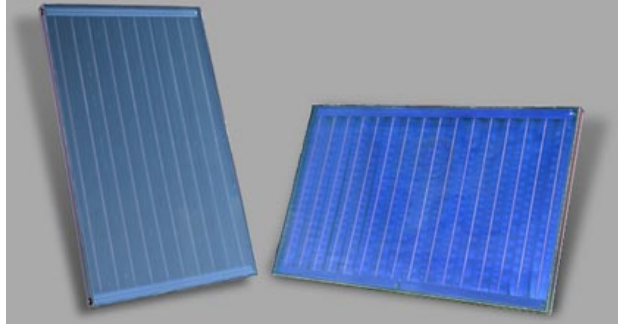

Flat Plate



Vacuum Tub

Unglazed



Plastic Absorber – Unglazed Collector

- 1** Inlet/Outlet
- 2** Header
- 3** Temperature sensor
- 4** Spacer
- 5** Absorber tube
- 6** Cap

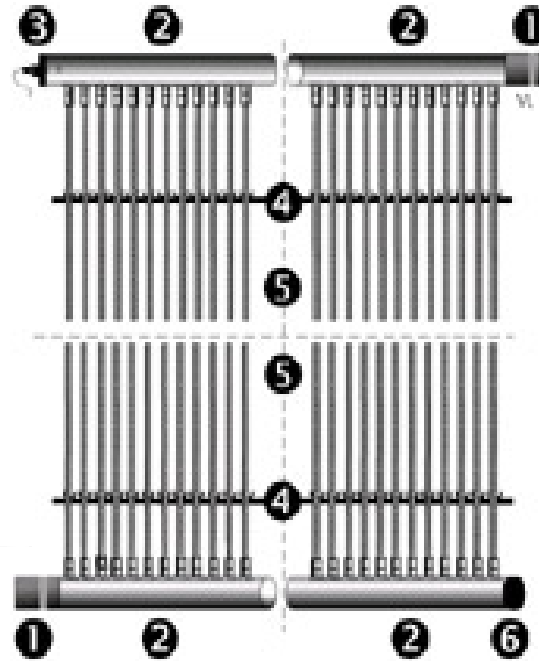

Flat Plate Collector

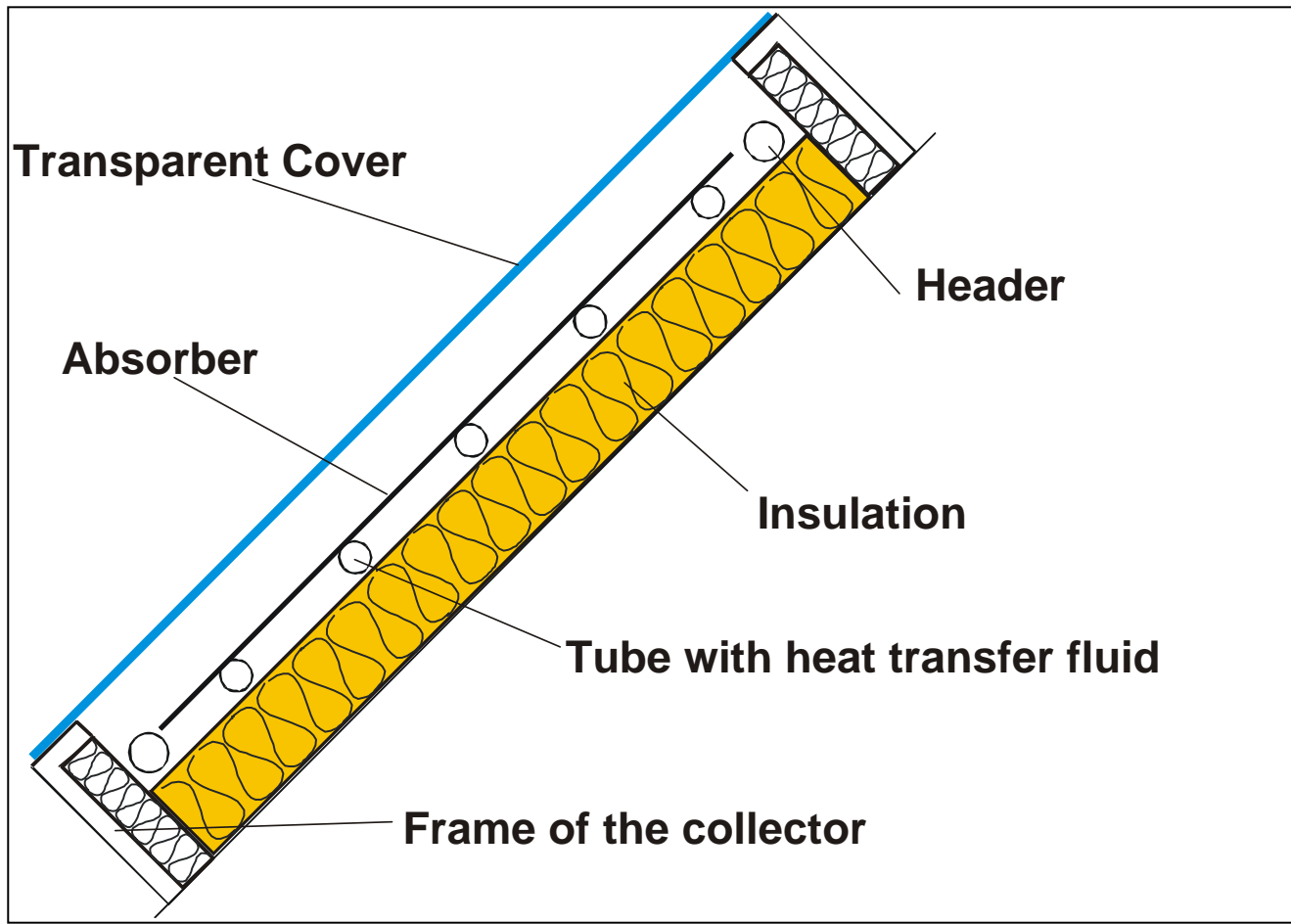

Section of flat plate collector

Flat Plate Collector

Aluminium Absorber



Aluminium absorber with pressed cooper tubes



Pressed tubes between 2 metal sheet

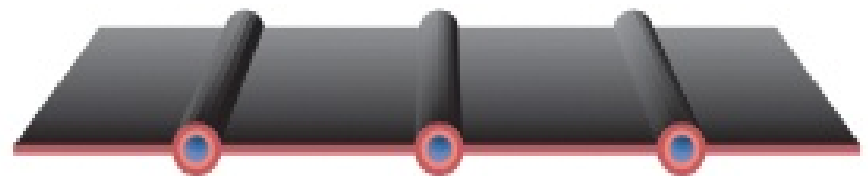

Tubes welded on metal sheet

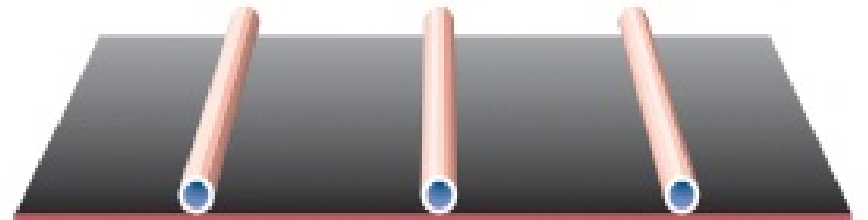

Flat Plate Collector

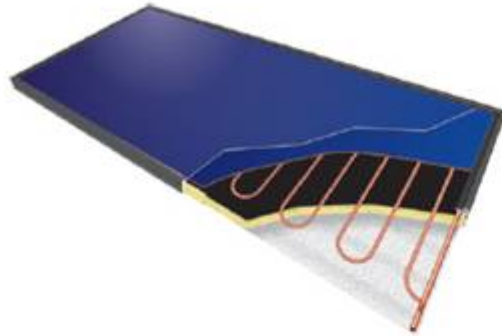

Absorber with serpentine tube (All surface cover)

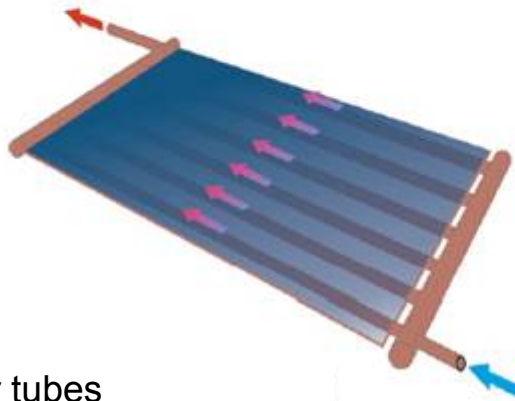

Absorber with linear tubes
(All surface cover)

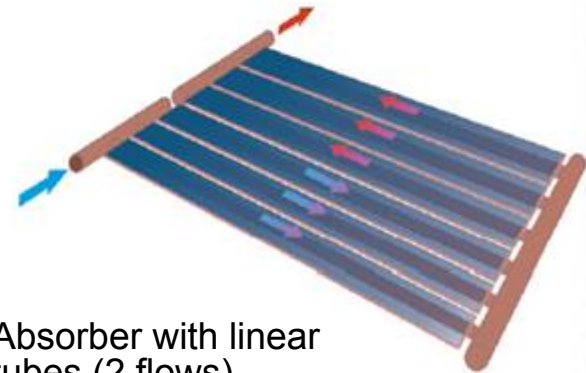

Absorber with linear
tubes (2 flows)

Flat plate Collector– Losses

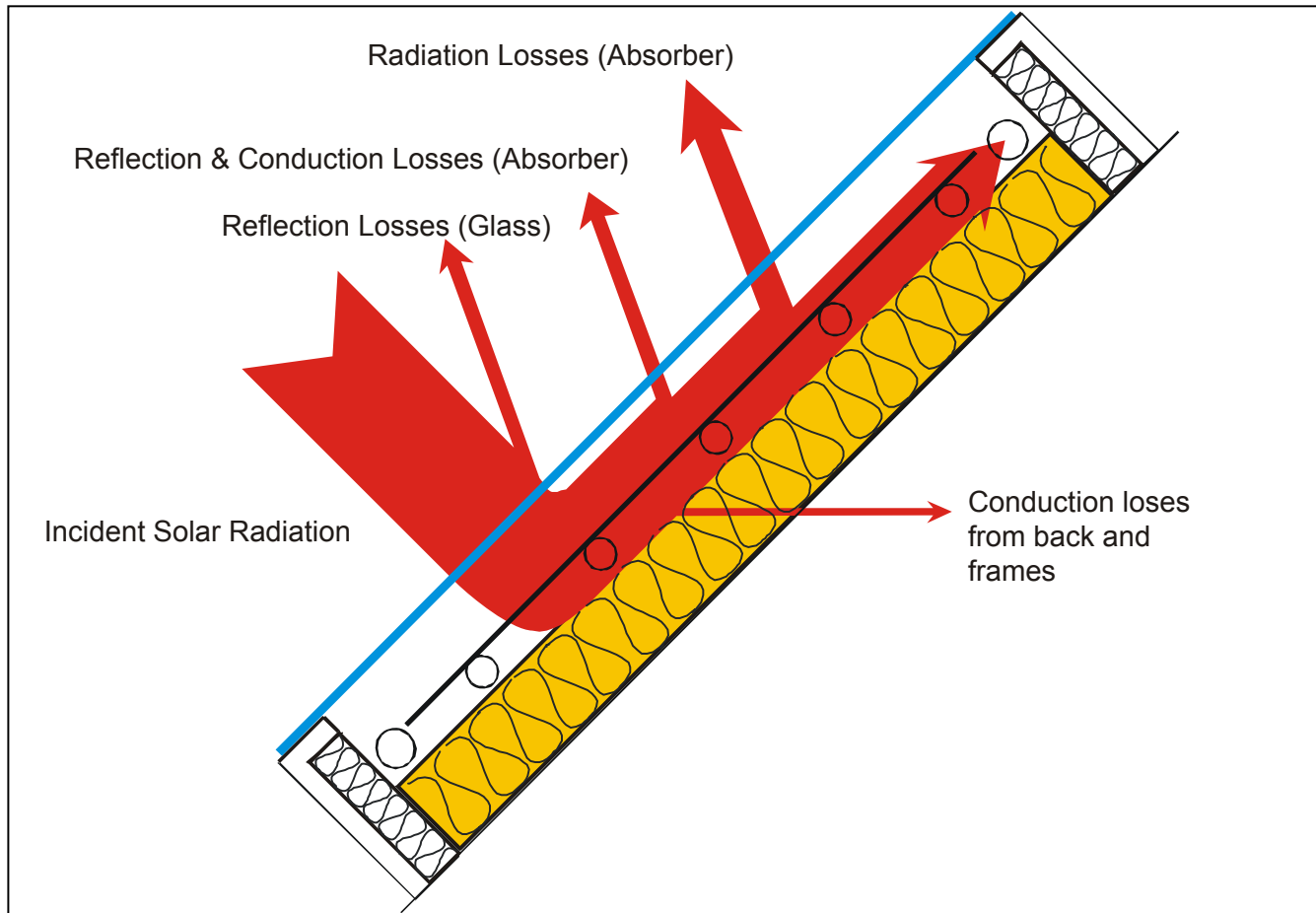

Thermal losses from flat plate collector

Selective surface

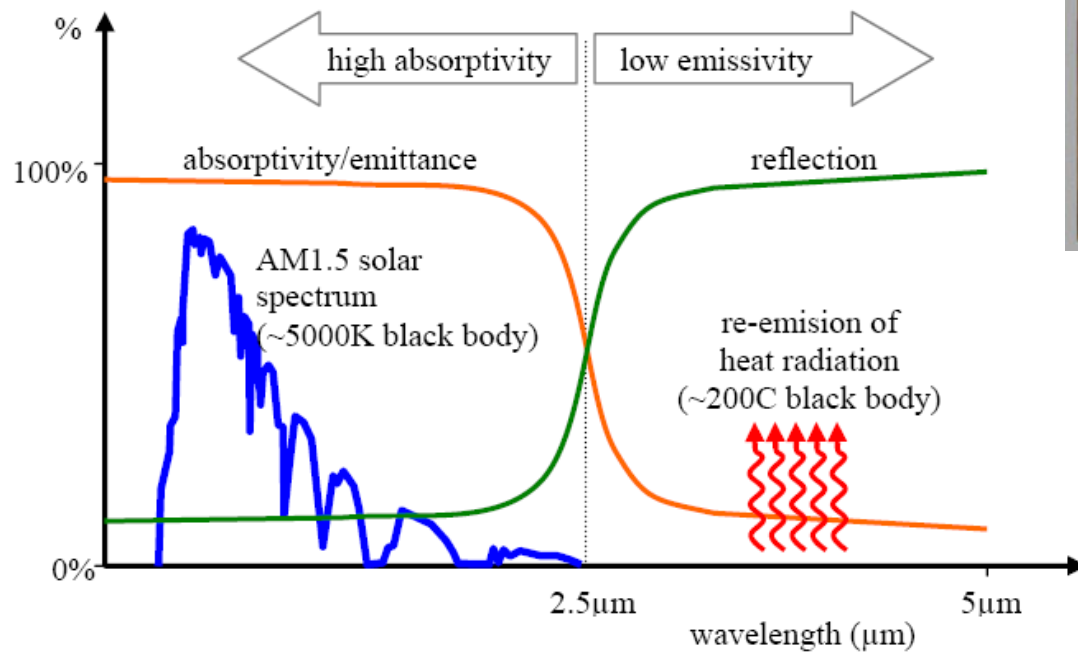

Selective surface



Black laquer

$\alpha = 95\%$
 $\epsilon > 80\%$

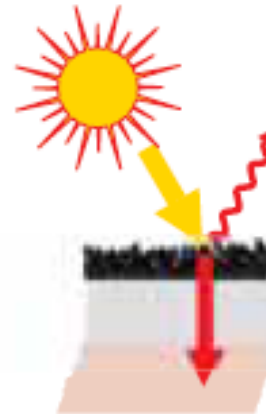

Black chrome

$\alpha = 95\%$
 $\epsilon = 12\%$

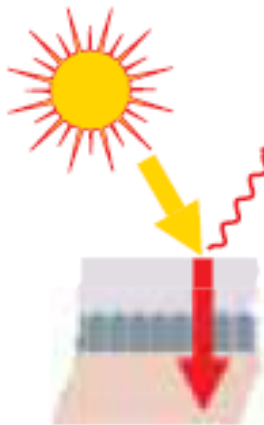

TiNOX

$\alpha = 95\%$
 $\epsilon = 5\%$



Selective coating

$\alpha = 95\%$
 $\epsilon = 5\%$

Source:Vaillant

Vacuum tube collector

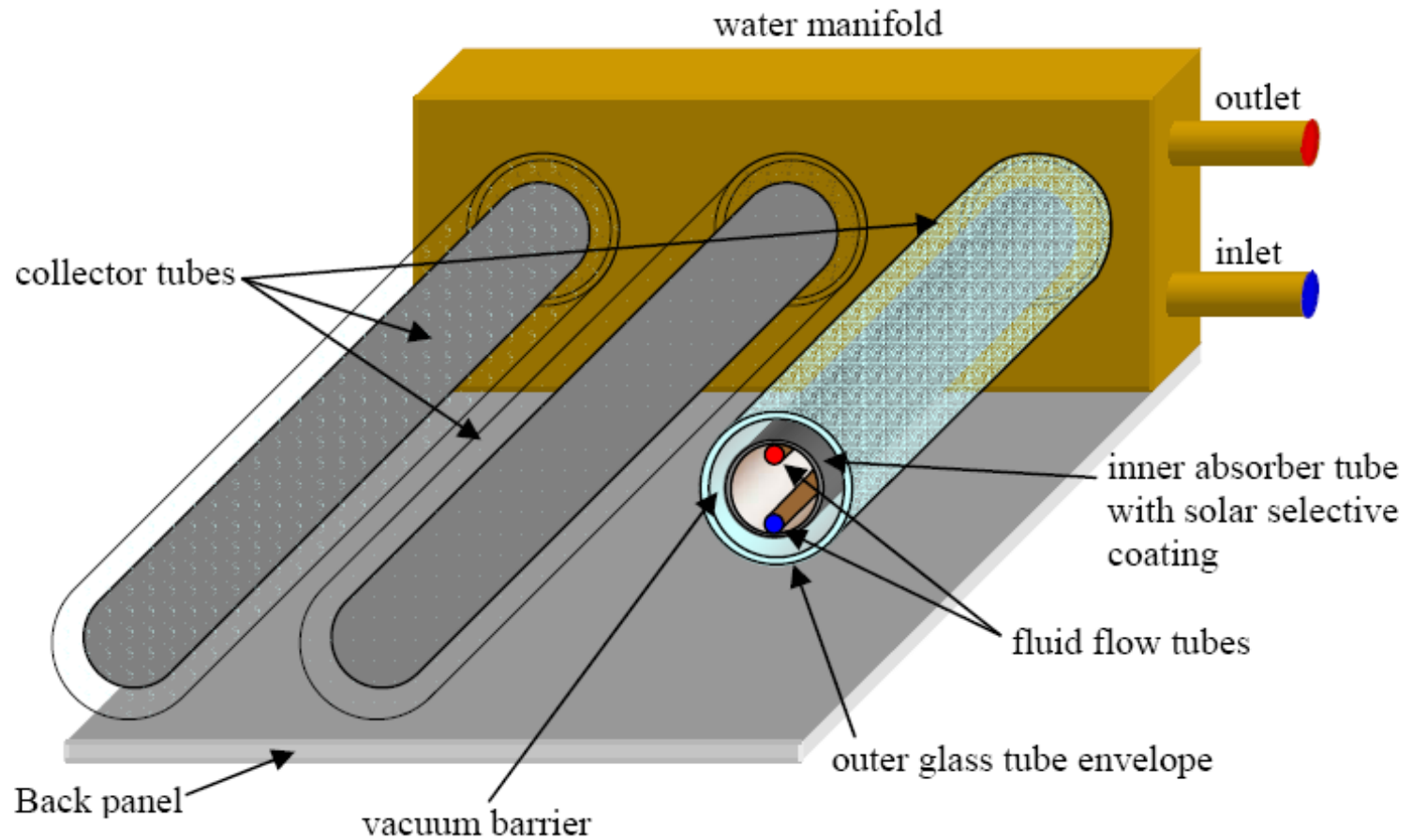

Vacuum tube collectors

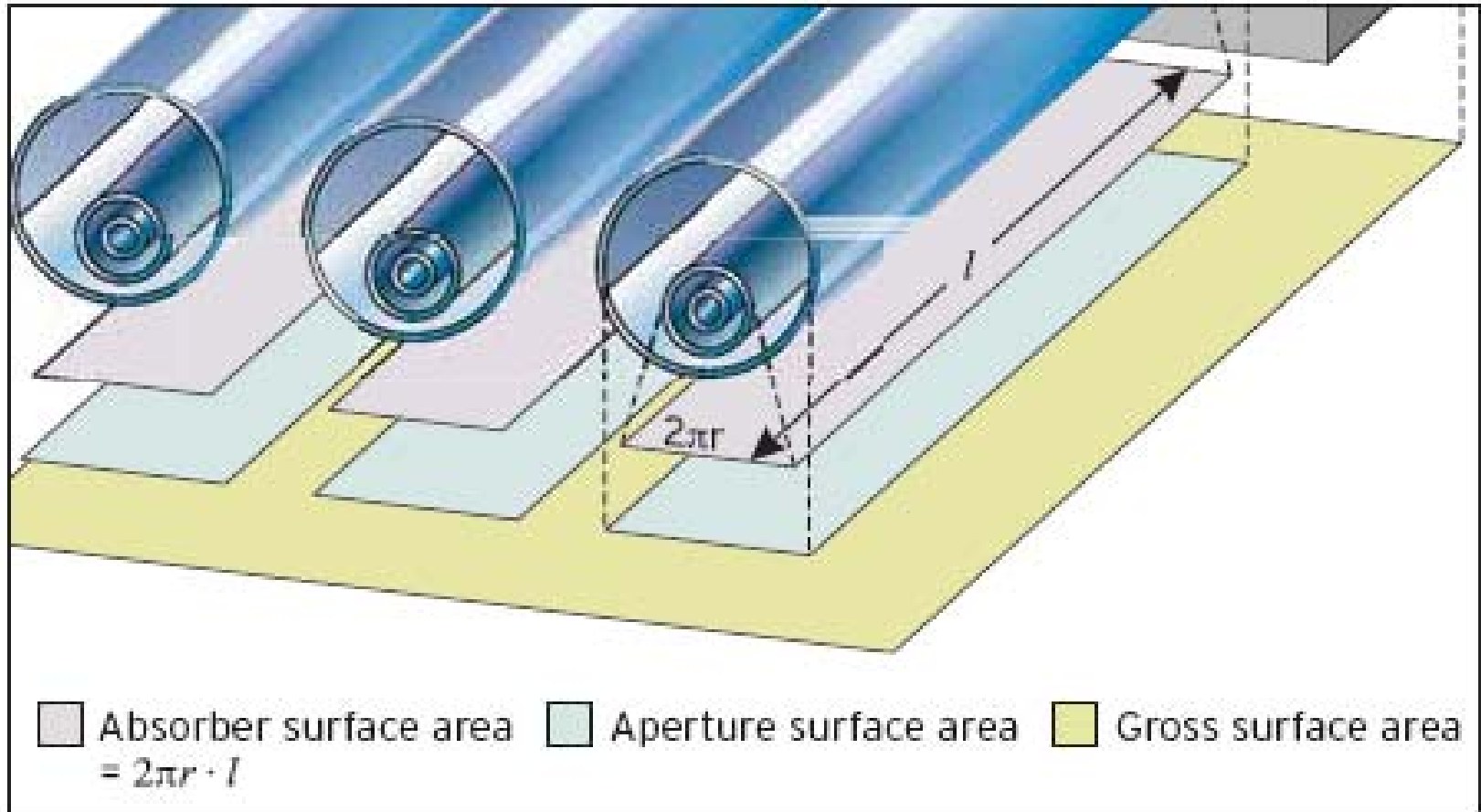

Concentrated Parabolic Collector - CPC

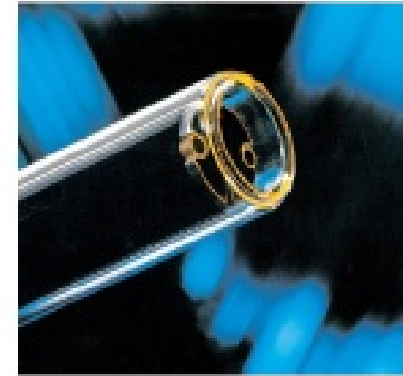
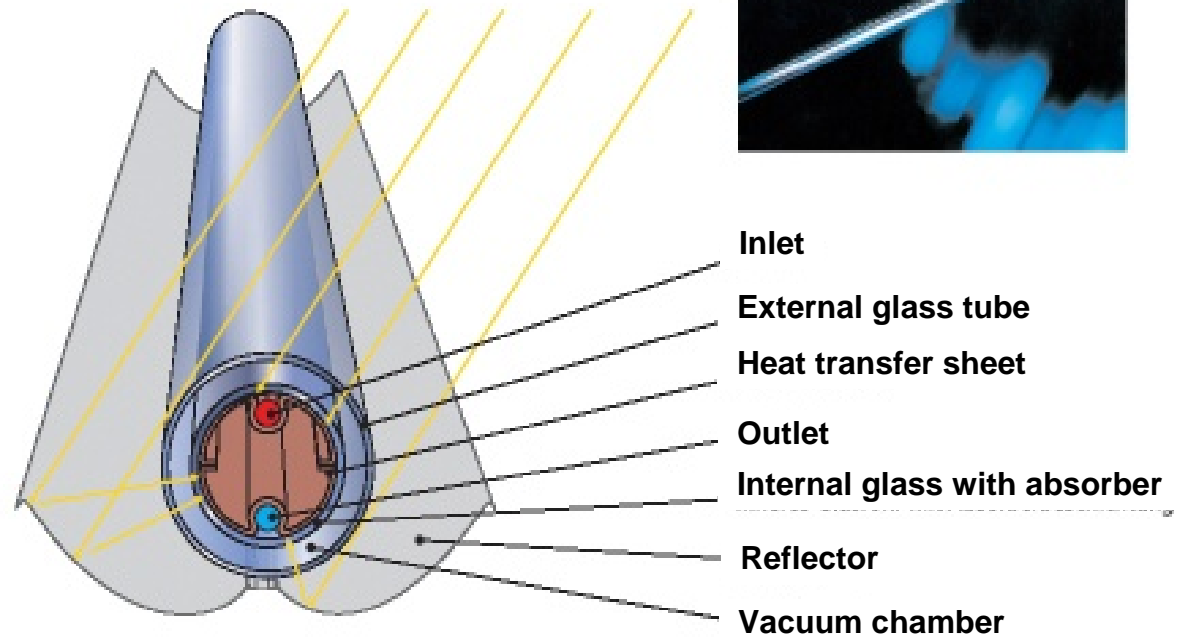

Solar collector characteristics

Collector Type	Price	Performance (kWh/m ² /year)	Typical use
Unglazed	Low	300	Pool heating
Flat plate (Black paint)	Mid	650	Pool heating, DHW
Flat plate (Selective absorber)	Mid	700	DHW, Space heating, Air conditioning
Vacuum tubes collector	Hi	850	Space heating, Air conditioning

Solar Key Mark

Way to guarantee the collector efficiency

- Randomly choose of the collector (Produce line or stored)
- Pass all the tests according to EN 12975/12976
- ISO certified production line
- Yearly inspection of the production line.
- Reinspection of the product every 2 years.



Domestic hot water heating

DHW heating system

Thermal solar systems

Thermosifonic

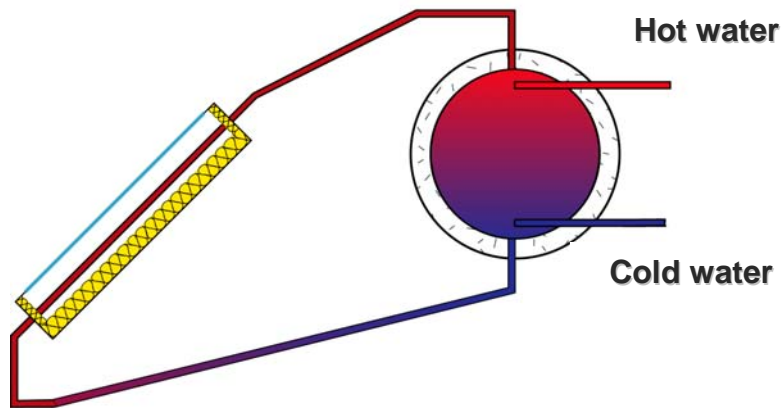

OPEN CIRCUIT

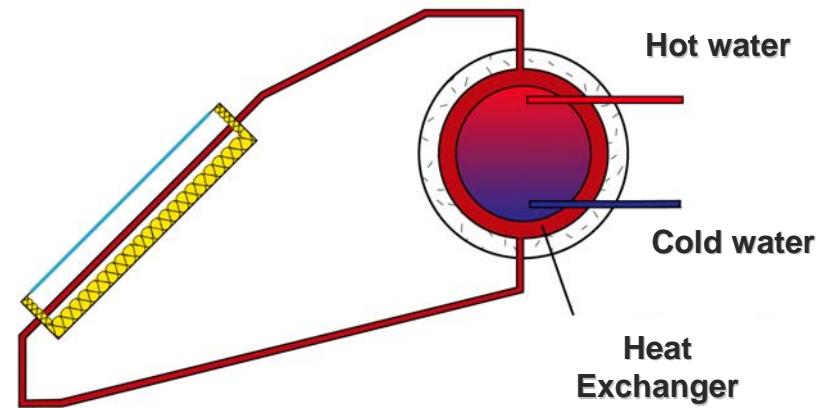

CLOSED CIRCUIT

Source: Target/DGS

Thermal Soar Systems

Forced circulation

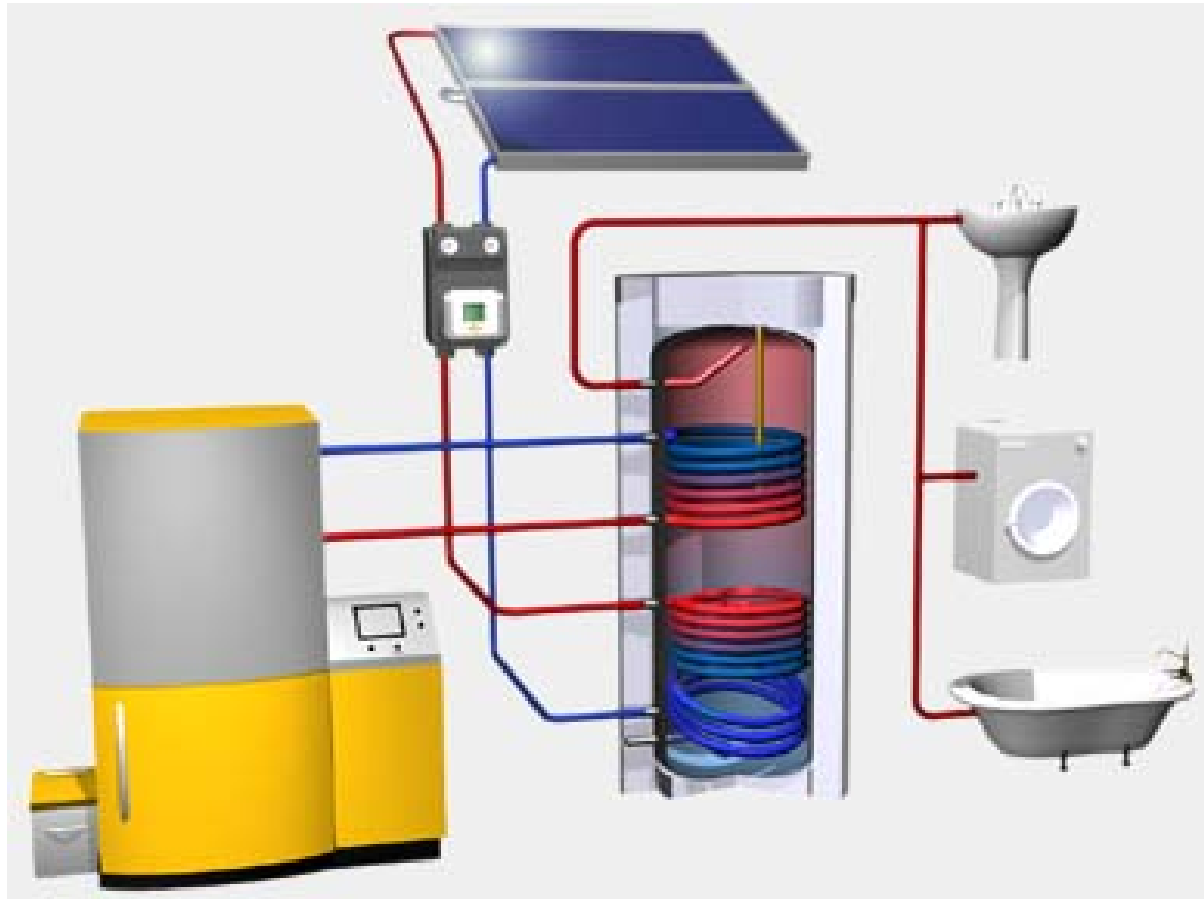

Source: IfaS

Combi Systems

- *Operational ways, characteristics and examples.*

"Combi" Systems

Properties

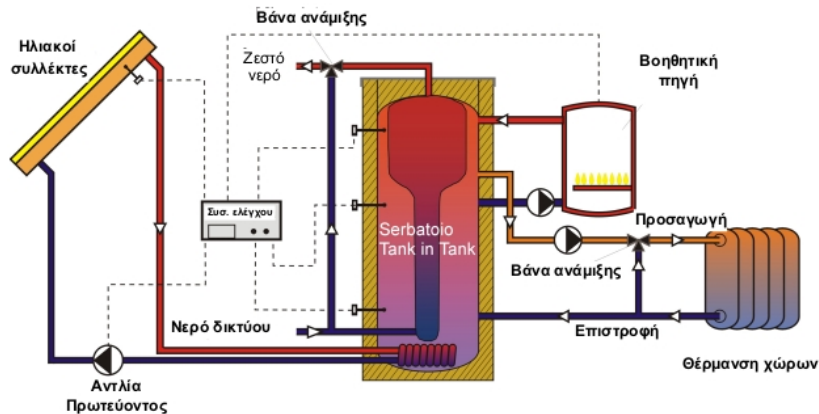

- High energy savings:
 - Introduction Solar technology in space heating
- Cost comparable with central solar systems.
- Possibility to combine with solar air condition units.

"Combi" systems

Advantages

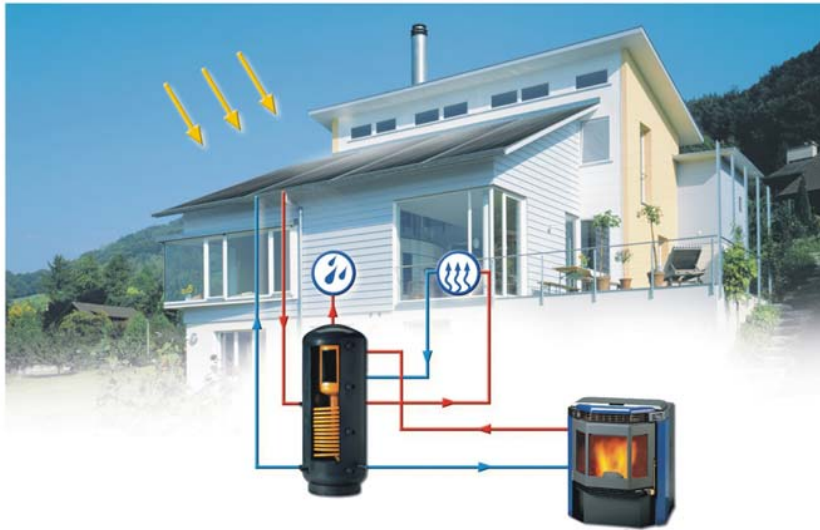

- Use at:
 - Homes
 - Hotels, Hospitals e.t.c.
 - Industry
- Already penetrated in European market
- Ability to cover high thermal load:
 - 30-50% only from sun
 - 100% (Combine with biomass)

Advanced market "Combi"

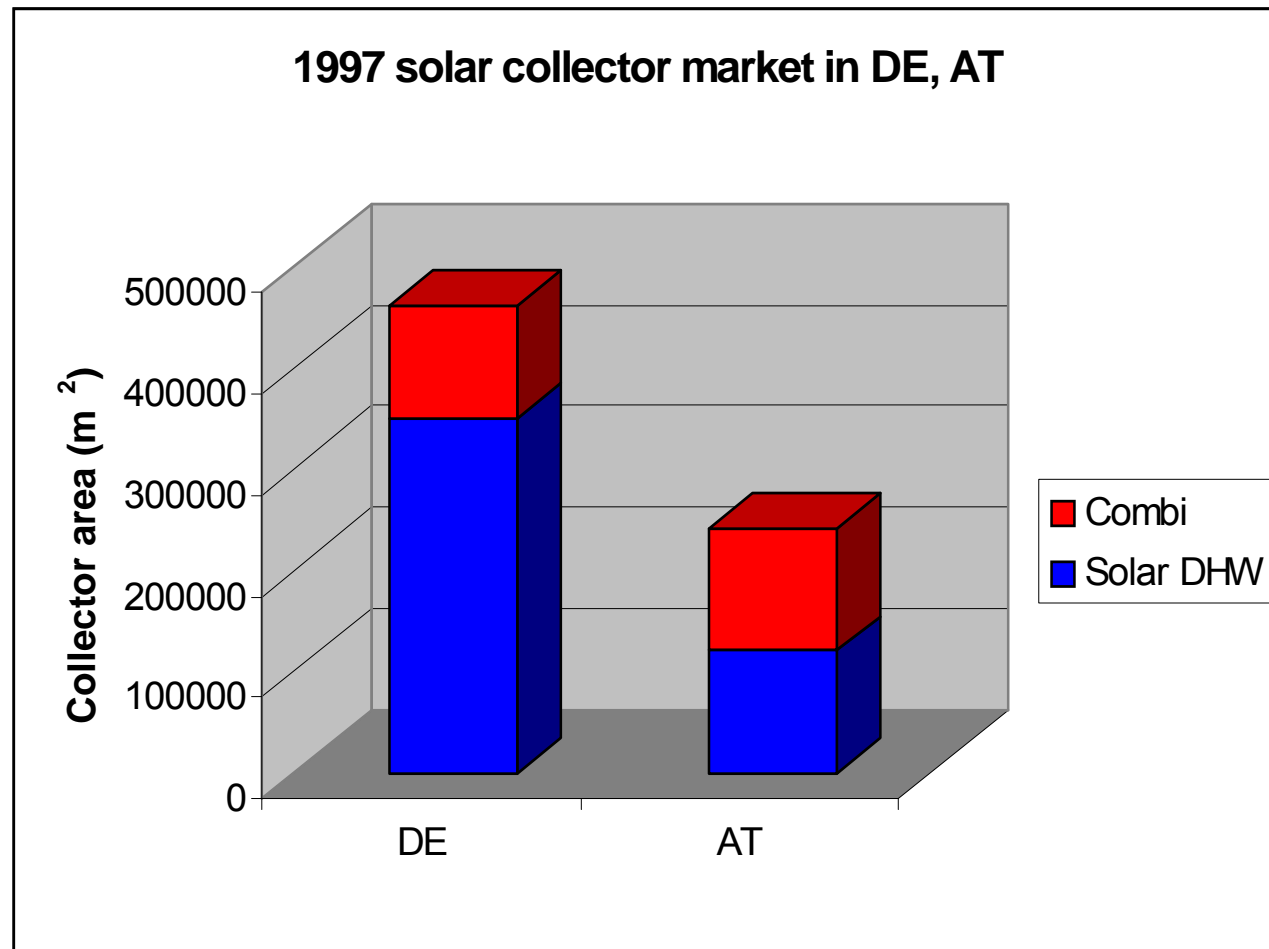

Combi Systems

Schematic diagram of a combi system for space heating, DHW and pool heating.

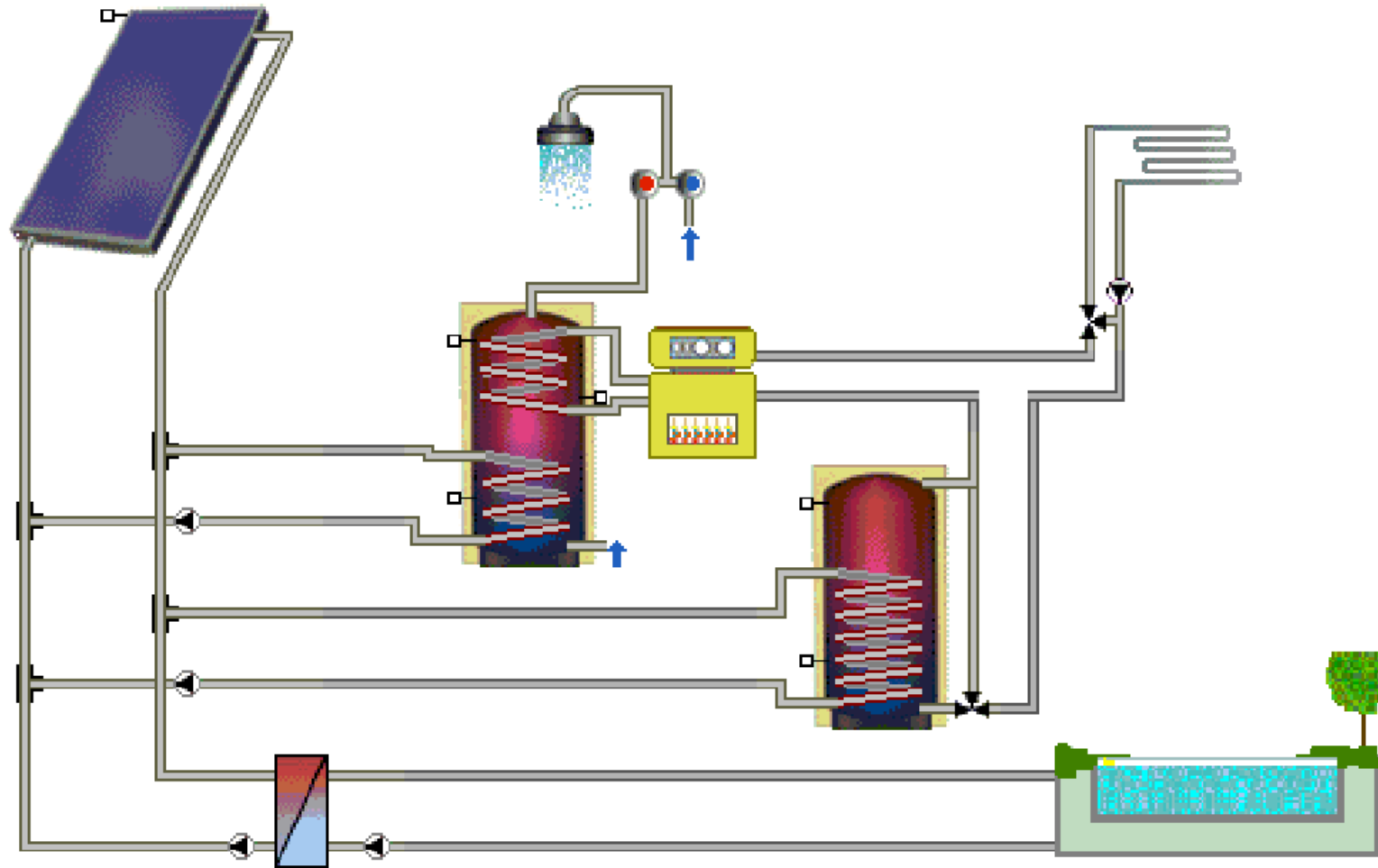

Combi System

Schematic diagram of a combi system for DHW and space heating

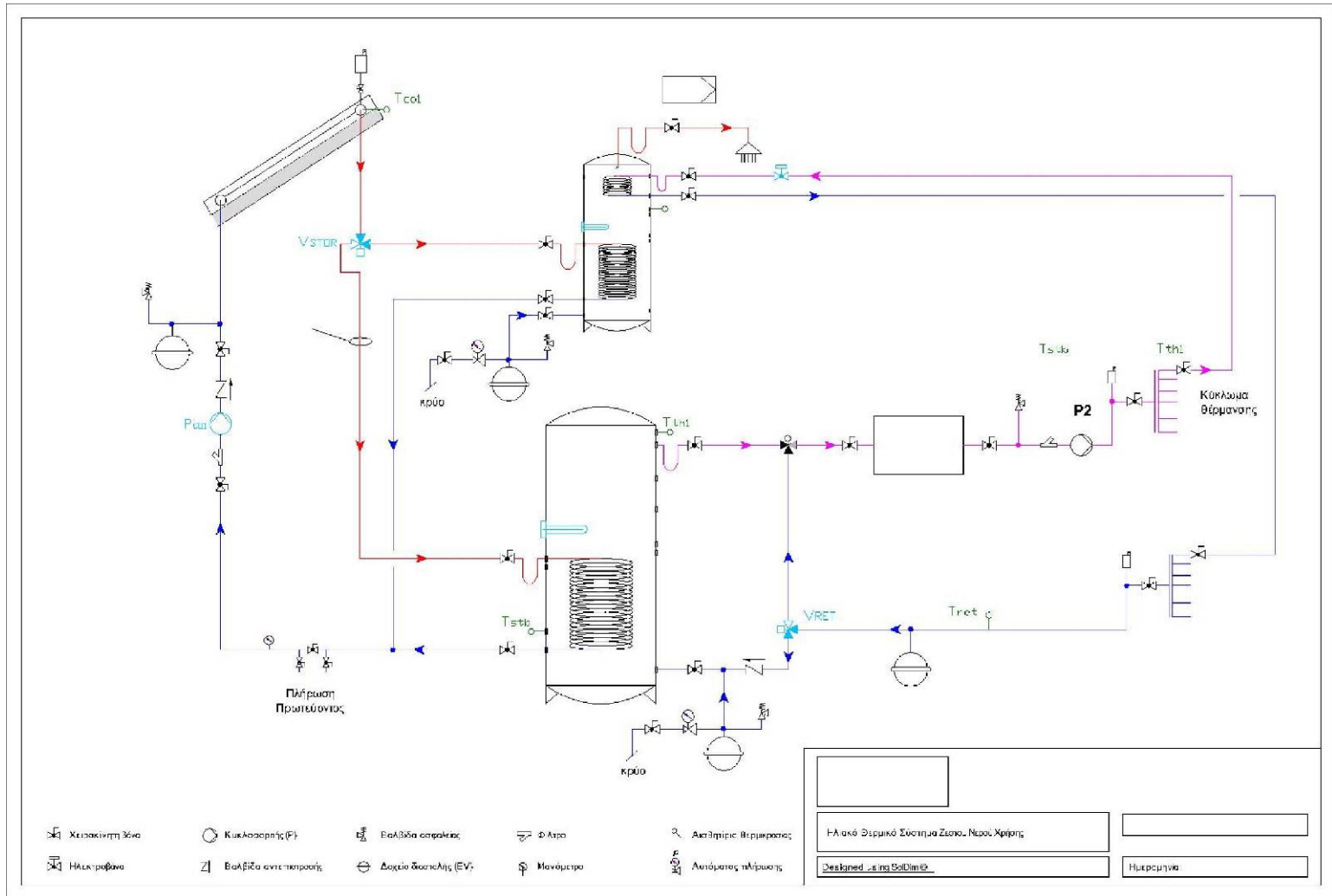

Combi Systems – tank in tank

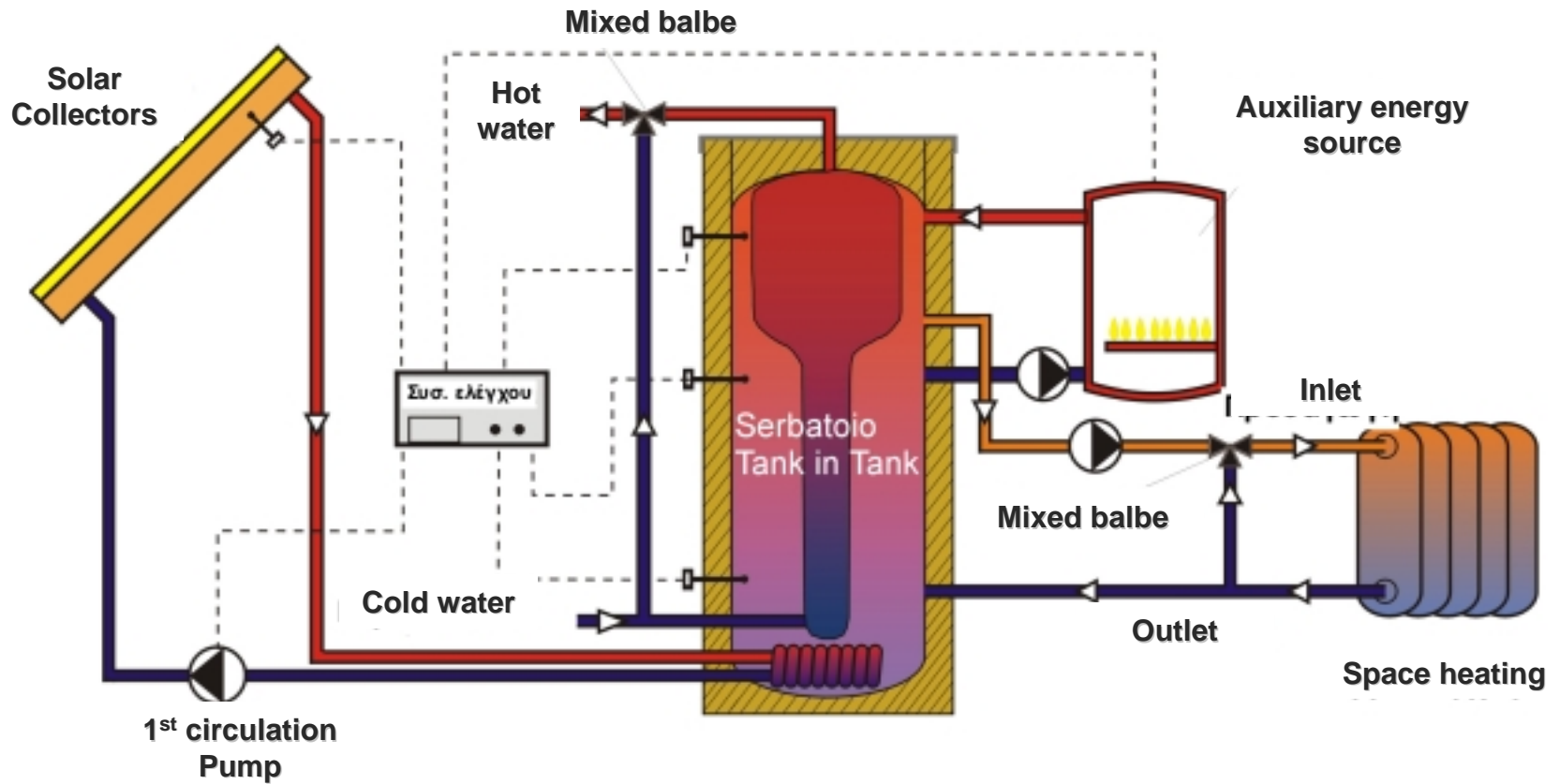

"Combi" systems

Dimensioning

- Domestic Consumption (at 45°C):
 - Low Consumption: 20 - 30 l /person/day
 - Mid Consumption: 30 - 50 l /person/day
 - Υψηλή κατανάλωση : 50 - 70 l /person/day
 - Washing Machine: 20-40 l / washing
 - Dishwasher: 20 l / washing
 - Example house with 4 persons total
 $4 \times 40 = 160$ l /day
- Storage tank for DHW = 0,7 - 1,5 x water requirement
120-240lt storage tank
- Daily energetic load:
 - $E = m \times c_p \times (\Delta T) \Rightarrow$
 - $E = 160 \text{ l} \times 1,16 \text{ Wh/ (l K)} \times (45-15)\text{K} \Rightarrow$
 - $E = 5.6 \text{ kWh}$
- Add energy required for space heating (about 70kWh/100m²)* coverage factor
 - $E = 70 \times 0.4 + 5.6 = 33.6 \text{ kWh}$
- Collector output: 1.2kWh/m² so $33.6 / 1.2 = 28 \text{ m}^2$ collector area
- Space Heating Storage 40lt/m² collector = 1120lt

The installation of "SOLLET" project at C.R.E.S



Heated Offices,
60m²

Storage tank, 500lt

Collector area,
13.5m²



Biomass burner,
35kW

Schematic diagram of the project

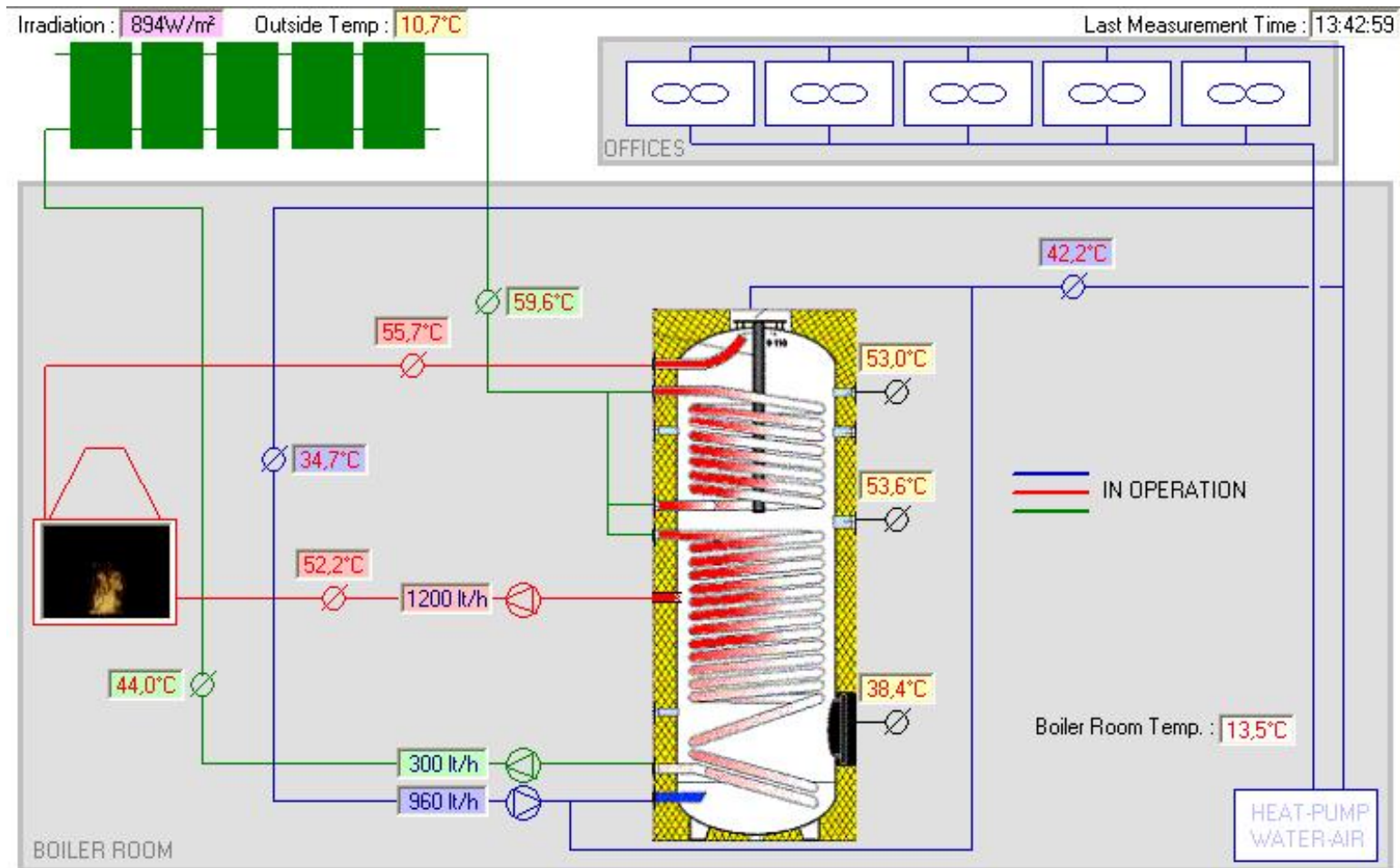

European project SOLLET (2): Germany, House, Dormagen

Solar Collectors



- Heating area 400m²
- Pellets burner 10 KW with heat exchanger air/water
- Fire place 10 KW with air/water heat exchanger
- 105 m² collector area.
- Water tank 3000 l
- Auxiliary heating system with natural gas.



Backup fire
place

European project SOLLET (3): Germany, House, Cologne



- Heating area 140m²
- Pellets burner 10 KW with heat exchanger air/water
- 28 m² collector area
- Water tank 1000 l



Pellet Burner



Solar collectors

Combi : Home (FR)



Source: IEA Task 26

Combi : Apartments (AT)



Source: GSWB

Combi : Apartments – Solar village (GR)







Ready Made Systems

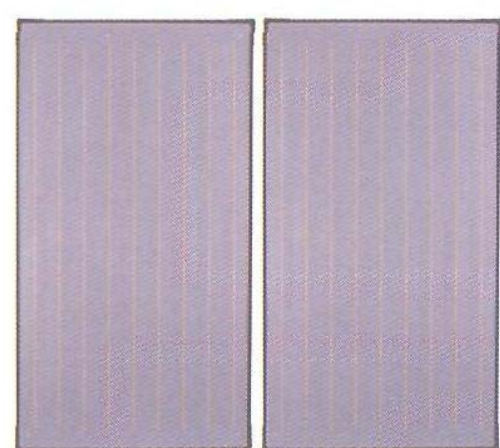

Καυστήρας Pellet

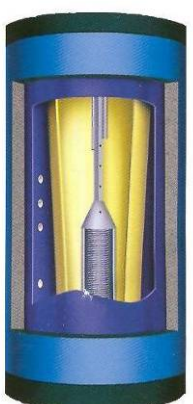

<p>Ηλιακοί συλλέκτες</p> 	<p>Υδραυλικό κιτ</p> 	<p>Δοχείο διαστολής</p> 
	<p>Θερμαντήρας</p> 	<p>Παρελκόμενα</p>  <p>Αυτοματισμός</p> 

Source: Buderus

Compact Systems: Plug n' play

*Dimensions (LxWxH)
10,5m x 2,5m x 2,6m
24 m² collector area
30-150 kW pellet burner*



Compact systems: Plug n' play

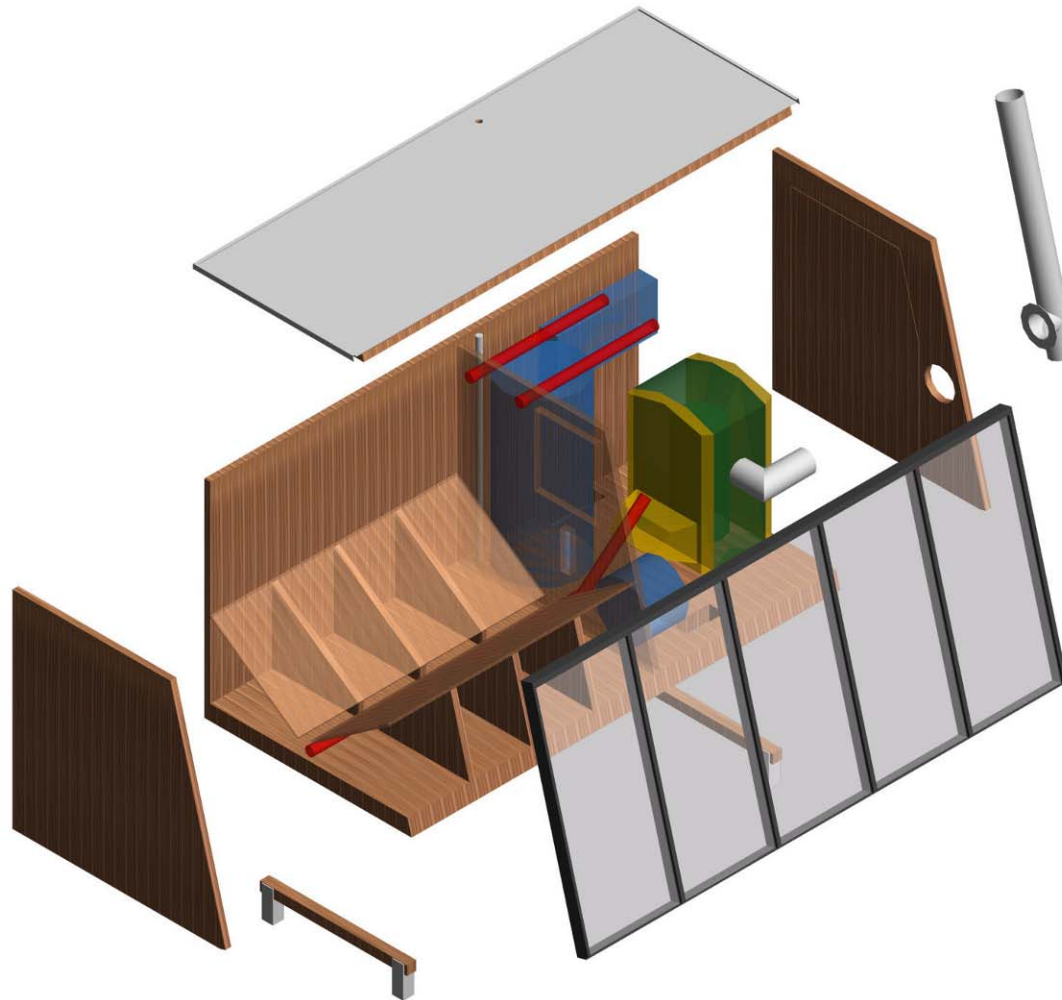

General Observations

- Solar heating systems can be combine with conventional space heating systems – Integrated with already installed systems.
- Combination with solar chillers to cover cooling loads (Use of excess energy).
- Cost: $\approx 400\text{€}/\text{m}^2$
- Collector area: 20% of the heated area for 40% load coverage (ex. 20m² flat plate collectors for 100m² house).
- Hot water Storage Volume: 10x heated area (1000lt tank for 100m² house)
- Must give emphasis at planning.
ex. Dimensioning of expansion tank of solar circuit. (stagnation temperatures).