



# Greek Solar Thermal Market

---

Market Development and Tools  
Awareness, International Trade



# Greek Solar Industry Association

---



Dimosthenous Str. 267, 17674 Athens, Greece.

Tel. +30210 9416057 Fax 9409119

[www.ebhe.gr](http://www.ebhe.gr)

Email: [info@ebhe.gr](mailto:info@ebhe.gr)

# GSIA Members

Est.1979

**Si ma**  
Solar Systems

**Calpak**

**DIANA**  
СOЛ AД HEATEPC ИHДИCTP

**MALTEZOS**

**SIELINE**

**PAPAEMMANOUEL-S.A.**

**Solar Flame**  
Premium  
Solar Systems

**SAMMLER**

**ΣΗΕ**

**ΗΛΙΟΘΕΡΜΟ**

ΗΛΙΟΘΕΡΜΑ-ΠΟΛΥΚΟΥΖΙΝΑ  
**Kipriotakis**  
2810-381300

**HELIOAKMI**

**EBHA**  
**EBIL**

**THERMOHELLAS**

**MD MELPO**

**Intersolar**

**SONNE**  
Aktion

**HELIONAL**  
Solar Systems

**HOWAT**

ΗΛΙΑΚΑ ΣΥΣΤΗΜΑΤΑ  
**ΔΗΜΑΣ**

**NOBEL**  
XYLINAKIS

**ROMINA**

**STIBETHERM**



# Products in Greece

---

- Solar water heater Thermosiphonic 95%
  - Private customers
- Central pump systems
  - Mainly professional customers
  - Hot water for hotels (95%), hospitals, etc
  - Process hot water
  - Solar cooling

# Domestic Pump System

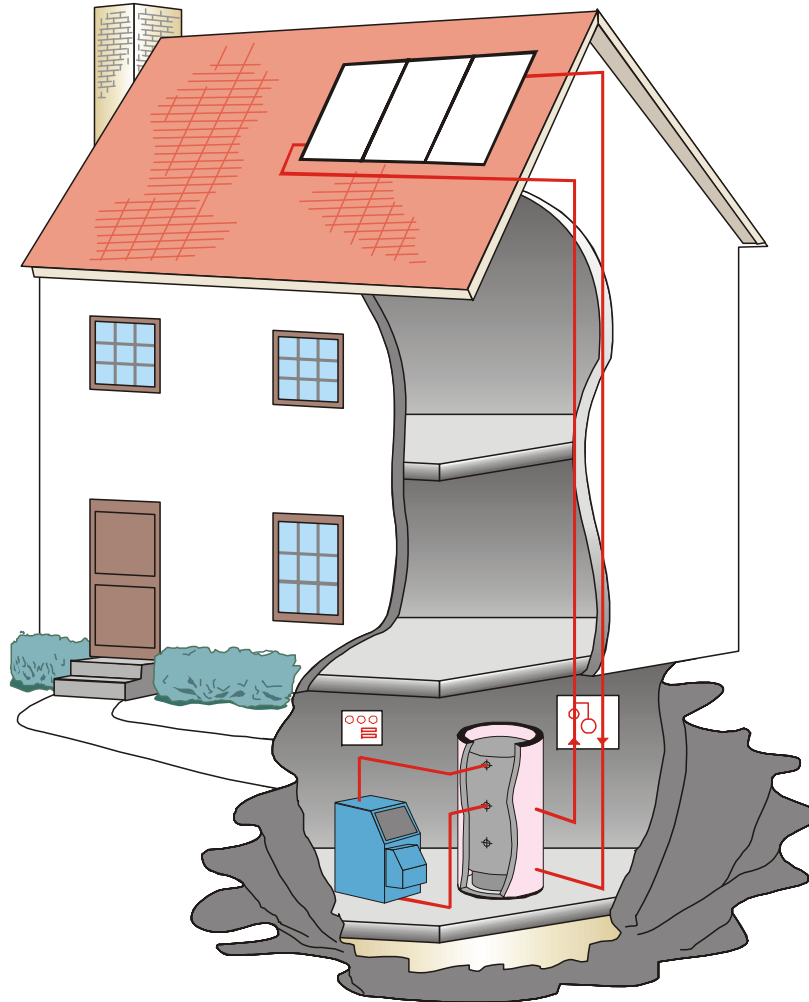

# Thermosiphonic Water Heater

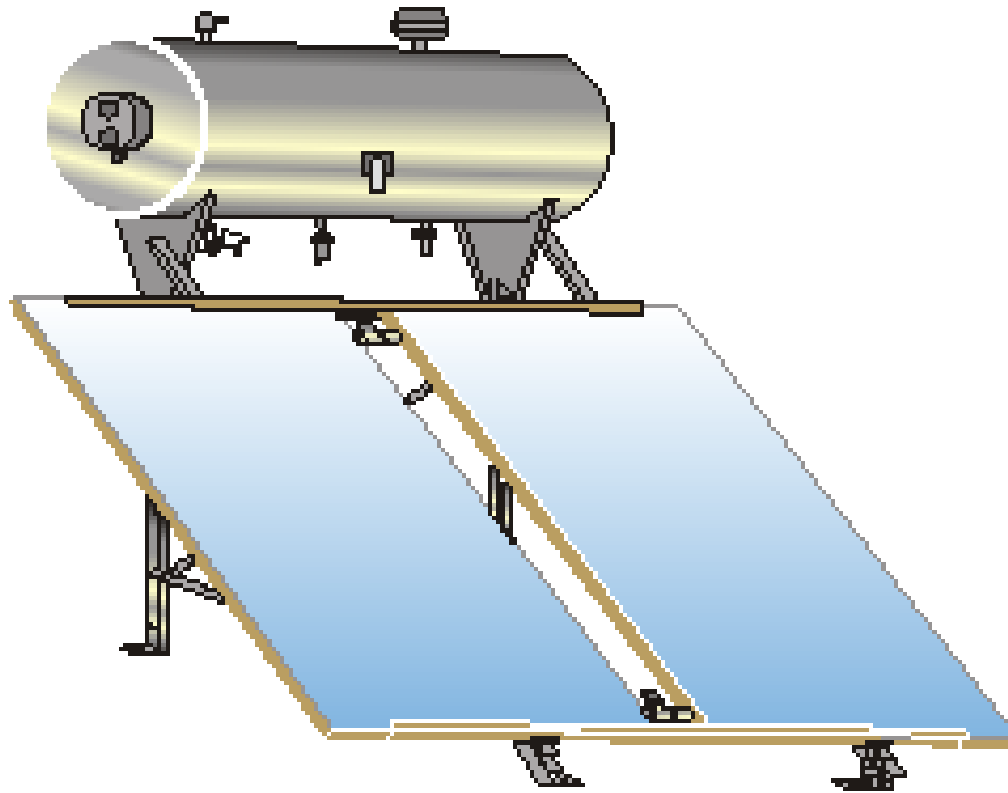



# Thermosiphonic Water Heater

---

- Requires flat roof or integration on roof or acceptance by customer
- Inexpensive installation
- Simple installation
  - No mistakes by installers
  - No negative influence on customers by installers

# Sales

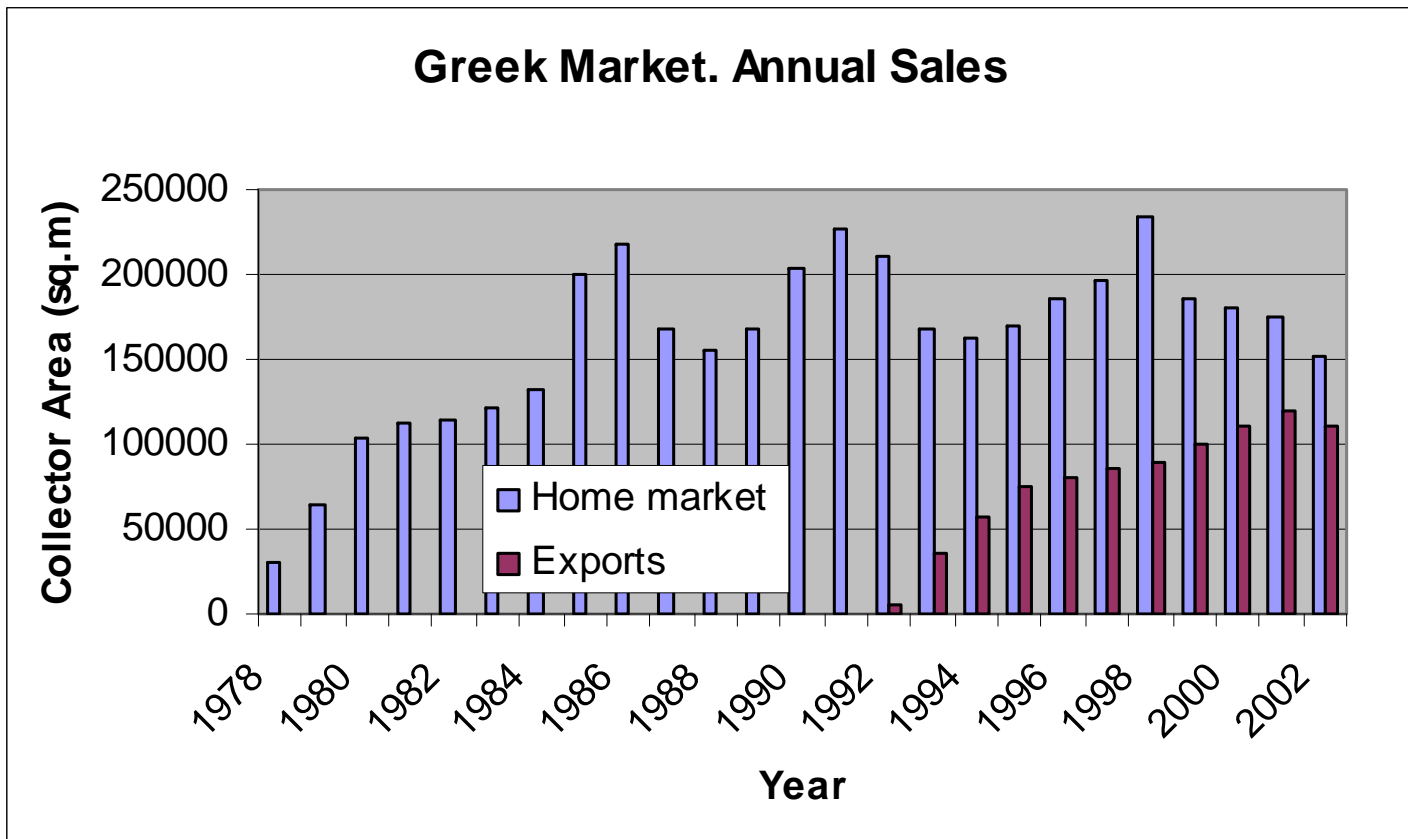



# Medium Term Trend

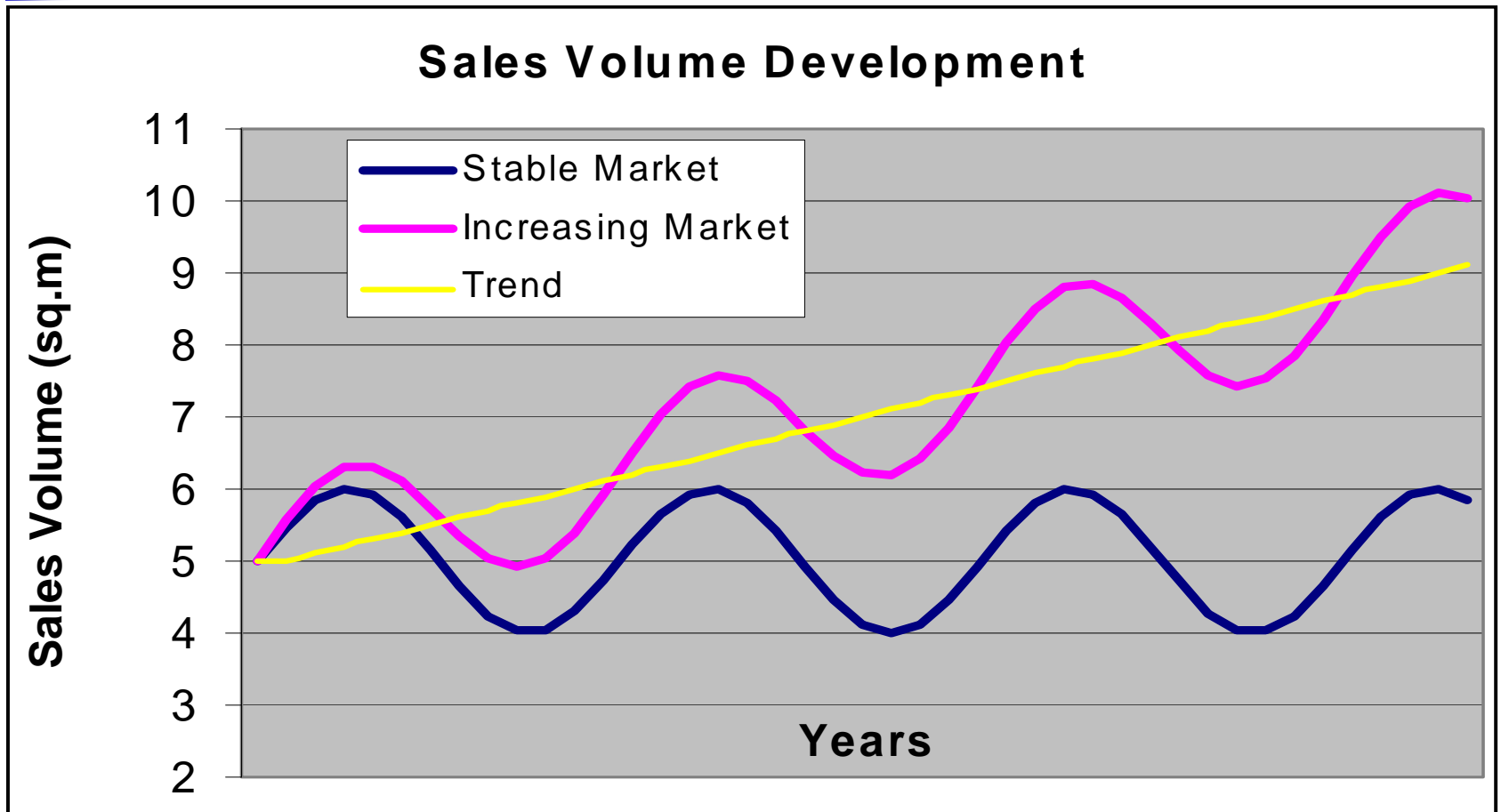



# Market Structure Now

---

Manufacturer

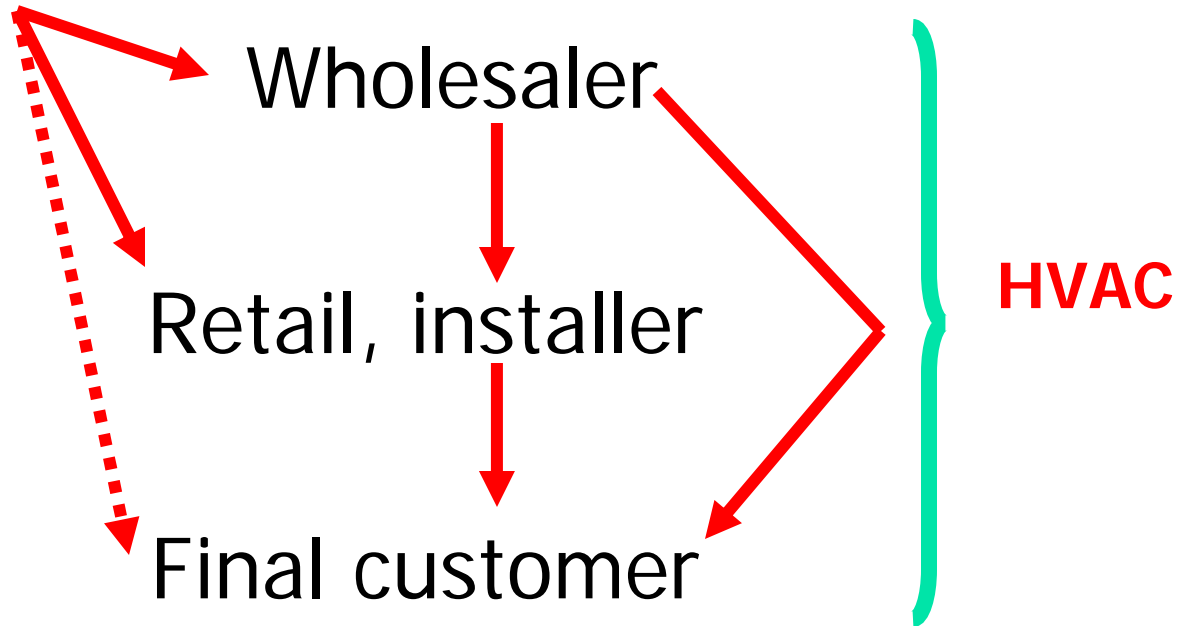



# Initial Market Structure

---

Manufacturer

Manufacturer

Wholesaler (solar only)

Final customer

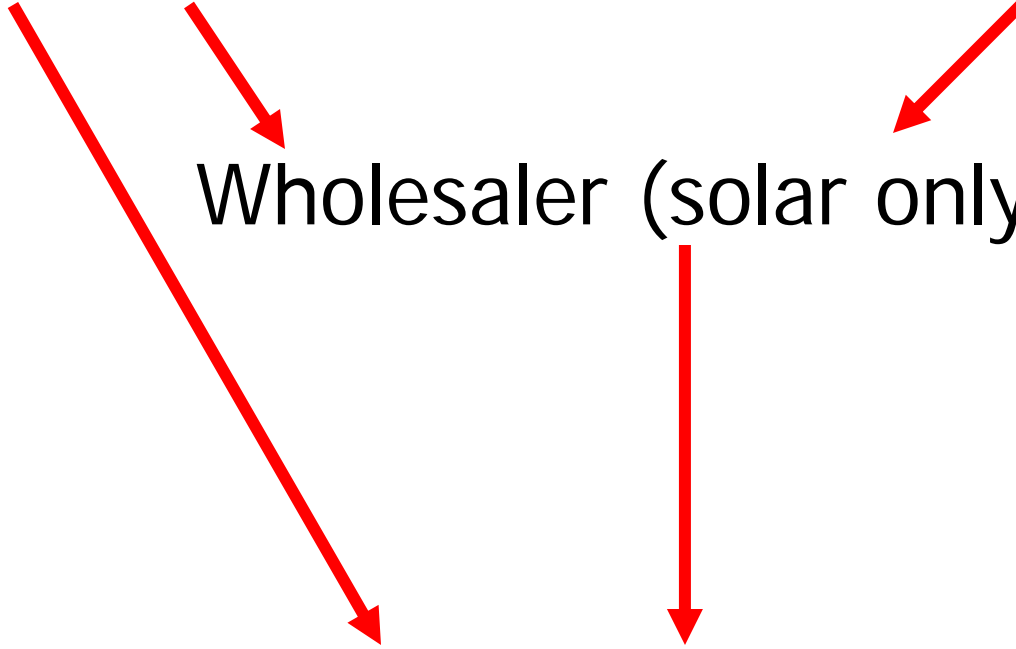



# Advertising/Awareness Campaigns

---

- 1979-1981 Industry, State  
(benefits of solar energy)
- 1984-1985 Industry, State  
(economy)
- 1995 Public Power Corporation



# Awareness for Solar

---

- **Hot water** : Complete
- **Process heat** : not satisfactory
- **Space heating** : only 'futuristic'
- **Solar cooling** : 'startup phase'
- Other in project level (drying, etc.)



# International Trade

---

## Positive

- European safety requirements CE mark
- European standards

- Solar Keymark



## Negative

- National & regional requirements



# Exported Products

---

- **Solar water heaters** ( Mediterranean, 37 countries all over)
- **Solar collectors** (Europe, mainly central)
- **Small solar tanks** - suitable for thermosiphonic systems- (Mediterranean)
- **Absorbers, etc.**- (Eastern Europe)



# Key to Enlarge Solar Market

---

**Simple and long term rules for subsidies**